

**STRATA PLAN OF PARCEL 1,  
BLOCK 309, DISTRICT LOT 526,  
GROUP 1, N.W.D., PLAN BCP22491**

"CITY OF VANCOUVER"  
B.C.G.S. 92G.025

**STRATA PLAN BCS 3321**

DEPOSITED AND REGISTERED IN  
THE LAND TITLE OFFICE AT  
NEW WESTMINSTER, B.C.

THIS 13 DAY OF FEB. 2009

*L. Blaschuk / 05*  
REGISTRAR

BB1047939 - BB1048014

SCALE 1:400

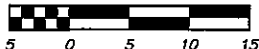

ALL DISTANCES ARE IN METRES.

THE INTENDED PLOT SIZE OF THIS  
PLAN IS 279mm IN WIDTH BY 432mm  
IN HEIGHT (B SIZE) WHEN PLOTTED AT  
A SCALE OF 1:400

"CAMERA"

1675 WEST 8th AVENUE  
VANCOUVER, BC



**INTEGRATED SURVEY AREA No. 31  
(VANCOUVER) NAD-83 (CSRS)**

THIS PLAN SHOWS HORIZONTAL GROUND-LEVEL MEASURED  
DISTANCES EXCEPT WHERE OTHERWISE NOTED, TO COMPUTE  
GRID DISTANCES, MULTIPLY GROUND LEVEL DISTANCES  
BY COMBINED FACTOR 0.9995988

**LEGEND**

GRID BEARINGS ARE DERIVED FROM OBSERVATIONS  
BETWEEN CONTROL MONUMENTS V-3448 AND V-3494

- ⊙ - DENOTES CONTROL MONUMENT FOUND
- - DENOTES LEAD PLUG FOUND
- - DENOTES LEAD PLUG PLACED
- - DENOTES STANDARD IRON POST FOUND
- - DENOTES STANDARD IRON POST PLACED
- NR - DENOTES NO RECORD
- D/R - DENOTES DESTROYED/RESET
- SL - DENOTES STRATA LOT
- PT. - DENOTES PART
- ⊕ - DENOTES COMMON PROPERTY
- ⊖ - DENOTES VENT BEING COMMON PROPERTY
- ⊗ - DENOTES MECHANICAL SPACE BEING COMMON PROPERTY
- ⊙ - DENOTES GAS METER BEING COMMON PROPERTY
- P1 - DENOTES PATIO BEING LIMITED COMMON PROPERTY FOR THE EXCLUSIVE USE OF SL. 1
- B7 - DENOTES BALCONY BEING LIMITED COMMON PROPERTY FOR THE EXCLUSIVE USE OF SL. 7
- T4 - DENOTES TERRACE BEING LIMITED COMMON PROPERTY FOR THE EXCLUSIVE USE OF SL. 4
- RT75 - DENOTES ROOF TERRACE BEING LIMITED COMMON PROPERTY FOR THE EXCLUSIVE USE OF SL. 75

THIS STRATA PLAN CONTAINS LIMITED COMMON  
PROPERTY ACCORDING TO SEC. 73 (a)(i) OF  
THE STRATA PROPERTY ACT.

I, MIKE E. SHAW, A BRITISH COLUMBIA LAND SURVEYOR  
CERTIFY THAT THE BUILDING SHOWN ON THIS STRATA PLAN  
IS WITHIN THE THE EXTERNAL BOUNDARIES OF THE LAND  
THAT IS THE SUBJECT OF THE STRATA PLAN.

DATE: FEBRUARY 5th, 2009.

*Mike E. Shaw*

BENNETT LAND SURVEYING LTD.  
B.C. & CANADA LAND SURVEYORS  
#201-9547 152nd STREET,  
SURREY, B.C. V3R 5Y5  
PHONE : 604-582-0717

DRAWING # 30578-15  
FILE # 30578-15\_FS  
DATE : FEBRUARY 5, 2009

THIS PLAN LIES WITHIN THE  
GREATER VANCOUVER REGIONAL DISTRICT

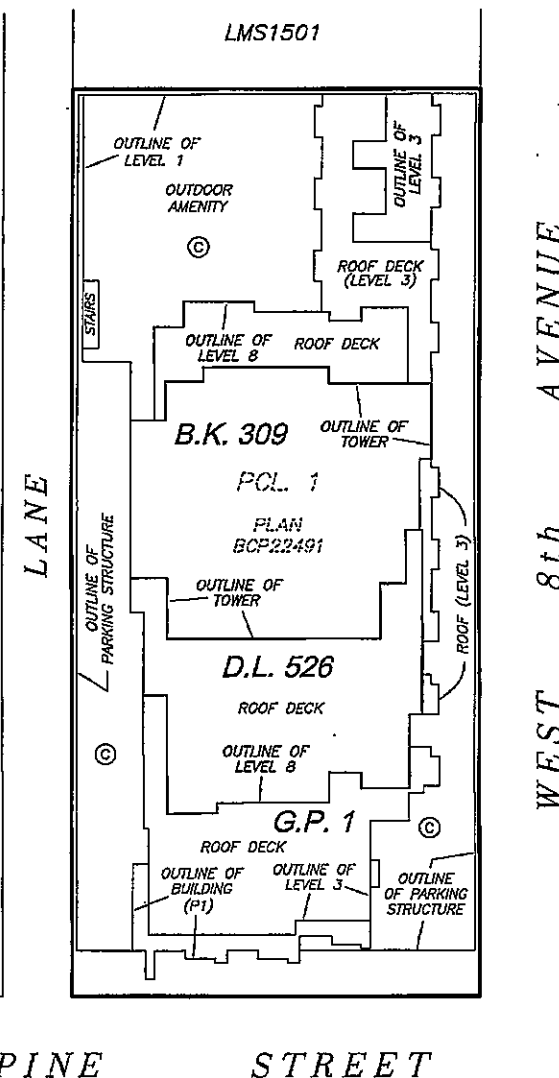

SEE SHEET #2 FOR  
BOUNDARY DIMENSIONS

SEE SHEET #3 FOR  
BUILDING LOCATION  
AND DIMENSIONS

ORIGINAL

BOUNDARY DIMENSIONS

STRATA PLAN BCS 3321

SCALE 1:400

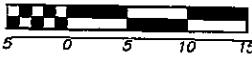

ALL DISTANCES ARE IN METRES.



FIR STREET

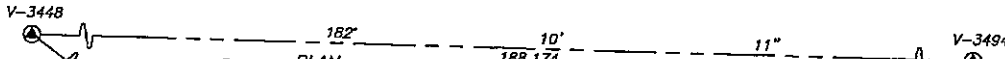

STRATA PLAN LMS1501

STRATA PLAN LMS2522

D.L. 526

PCL. 1

PLAN BCP22491

B.K. 309

G.P. 1

WEST 8th AVENUE

PINE STREET

I, MIKE E. SHAW, A BRITISH COLUMBIA LAND SURVEYOR, OF LANGLEY, IN BRITISH COLUMBIA, CERTIFY THAT I WAS PRESENT AT AND PERSONALLY SUPERINTENDED THE SURVEY REPRESENTED BY THIS PLAN, AND THAT THE SURVEY AND PLAN ARE CORRECT. THE FIELD SURVEY WAS COMPLETED ON THE 5th DAY OF FEBRUARY, 2009. THE PLAN WAS COMPLETED AND CHECKED, AND THE CHECKLIST FILED UNDER # ECP92970, 10th DAY OF FEBRUARY, 2009.

*Mike E. Shaw* B.C.L.S.

DRAWING # 30578-15  
FILE # 30578-15\_POST

DATE : FEBRUARY 5, 2009

*M.E.S.*

ORIGINAL

FILED VABC3321 RCD-2009-02-13 PRINT 2009-03-30-16:11:30 747726

# BUILDING LOCATION AND DIMENSIONS

## STRATA PLAN BCS 3321

SCALE 1:300



ALL DISTANCES ARE IN METRES.

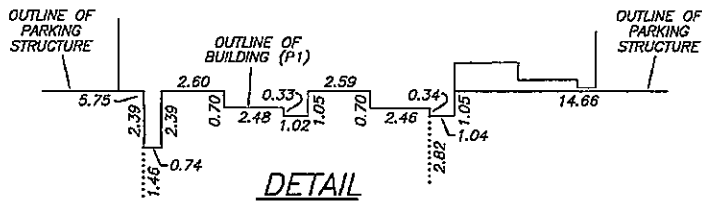
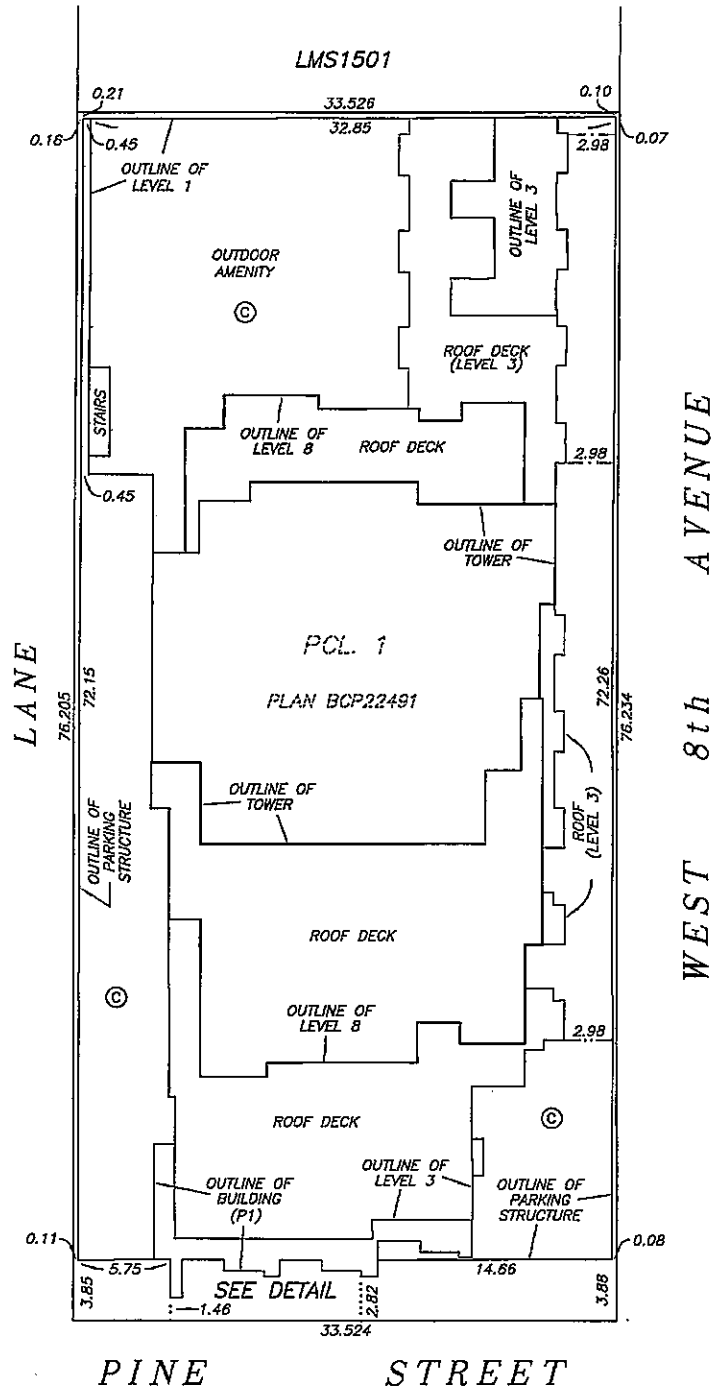

DATE : FEBRUARY 5, 2009

M.E.S.

DRAWING # 3057B-15  
FILE # 3057B-15\_CE

ORIGINAL

FILED VABCS3321 RCD-2009-02-13 PNT: 2009-03-30-16:11:30.747726

STRATA PLAN BCS 3321

FILED VBCS3321 RCD:2009-02-13 PRT: 2009-03-30-16:11:30.74726

OWNER :

INTRACORP CAMERA DEVELOPMENT LTD.  
(INCORPORATION No. 0735099)

  
AUTHORIZED SIGNATORY Don S. FORSAEN

AUTHORIZED SIGNATORY

  
WITNESS AS TO BOTH SIGNATURES

PROJECT MANAGER  
OCCUPATION OF WITNESS

900-666 BURRARD ST. VANCOUVER, BC  
ADDRESS OF WITNESS V6C 2X8

MORTGAGEE :

UNITED OVERSEAS BANK LIMITED

  
AUTHORIZED SIGNATORY K. JIN KOH

AUTHORIZED SIGNATORY

  
WITNESS AS TO BOTH SIGNATURES  
JANE TAYLOR

BANKER  
OCCUPATION OF WITNESS

1180-650 W. GEORGIA ST. VANCOUVER BC  
ADDRESS OF WITNESS

MORTGAGEE :

TRAVELERS GUARANTEE COMPANY OF CANADA

  
AUTHORIZED SIGNATORY KERRY NAGY

AUTHORIZED SIGNATORY

  
WITNESS AS TO BOTH SIGNATURES

ACCOUNTANT  
OCCUPATION OF WITNESS

900-666 BURRARD ST. VANCOUVER, BC  
ADDRESS OF WITNESS V6C 2X8

I, MIKE E. SHAW, A BRITISH COLUMBIA LAND SURVEYOR,  
CERTIFY THAT THE BUILDING INCLUDED IN THIS STRATA  
PLAN HAS NOT, AS OF FEBRUARY 5th, 2009, BEEN  
PREVIOUSLY OCCUPIED.

 B.C.L.S.

DATE : FEBRUARY 5, 2009



# SECTION A - A'

# STRATA PLAN BCS 3321

SCALE 1:150

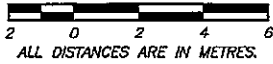

FILED VABC3321 RCD:2009-02-13 PNT: 2009-03-30-16:11:30-747726

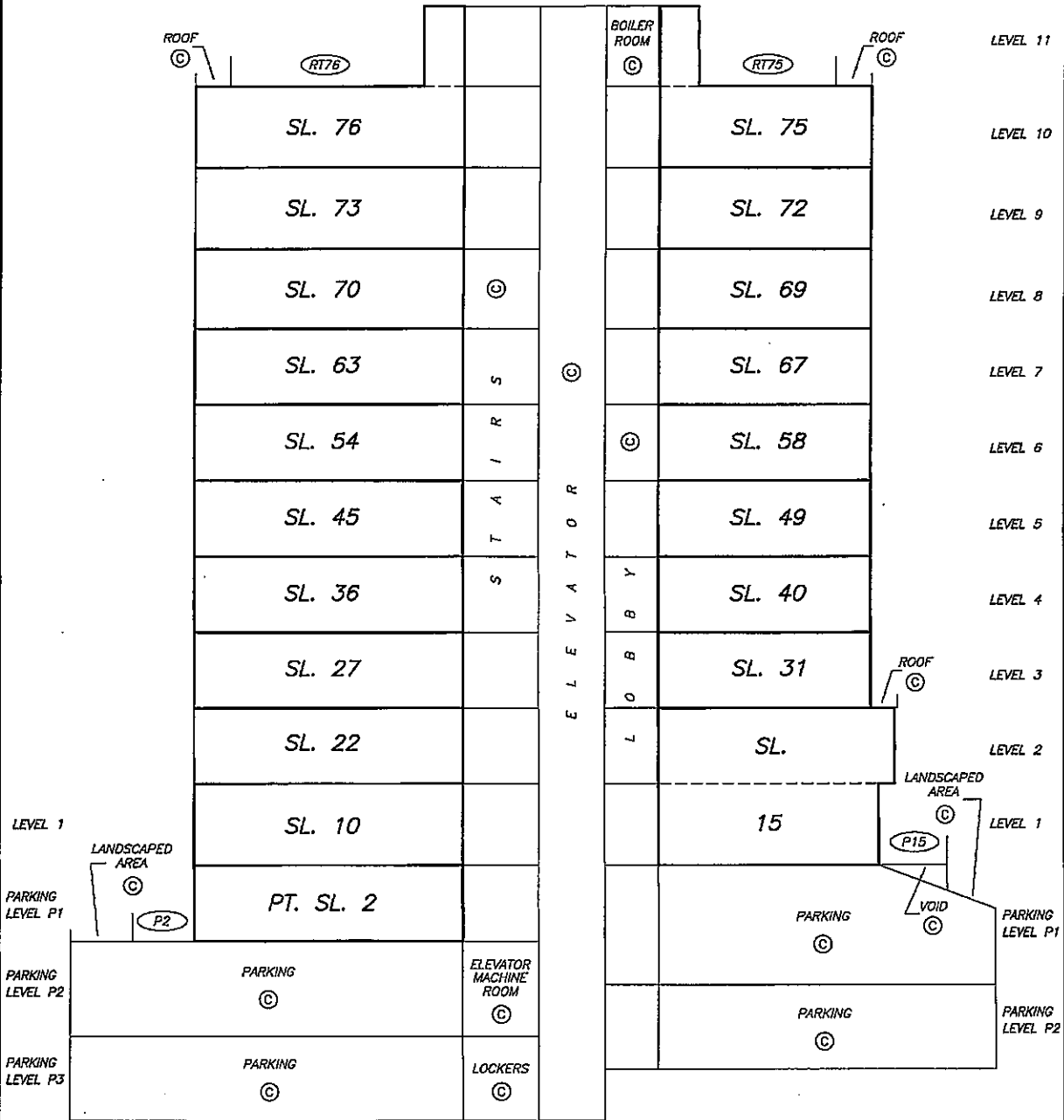

# STRATA PLAN BCS 3321

## PARKING LEVEL P3 FLOOR PLAN

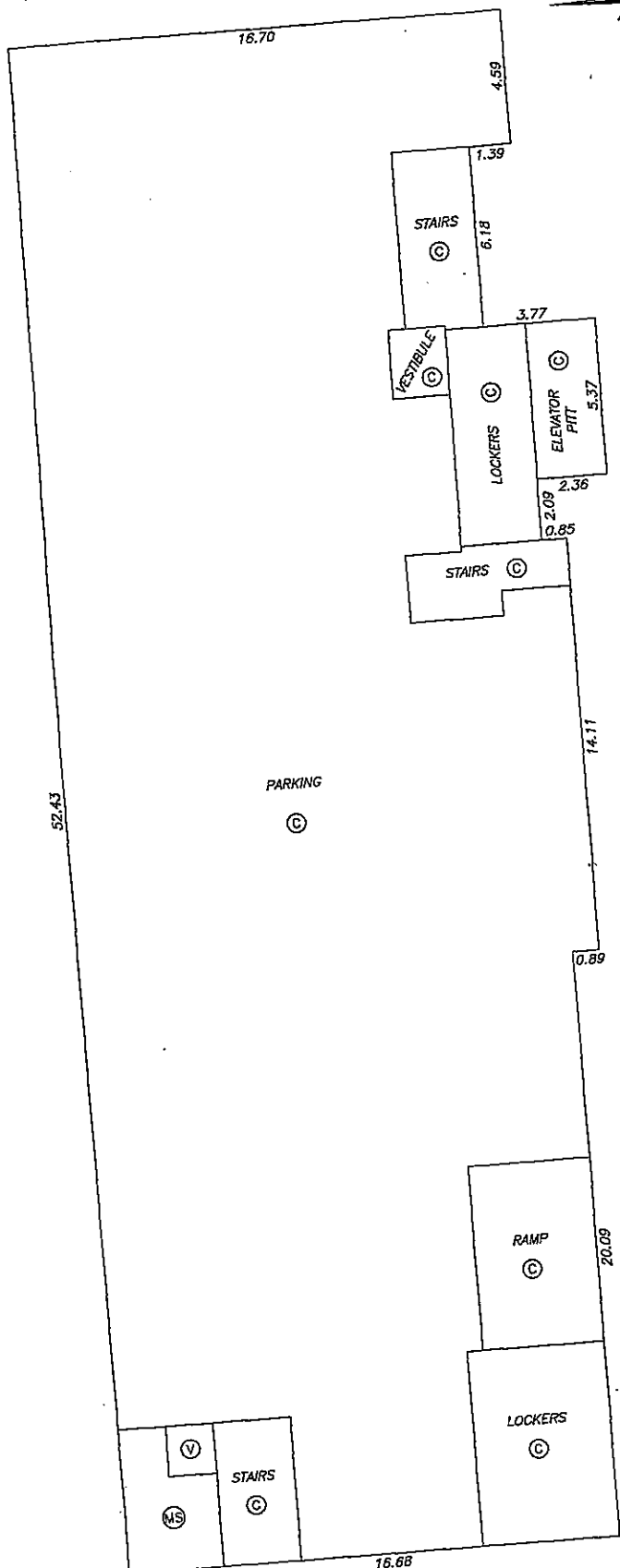
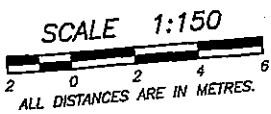

FILED  
VARCS3321  
RCM:2009-02-13  
PRINT: 2009-03-30-16:11:30.747726

DATE : FEBRUARY 5, 2009  
M.E.S.

PARKING LEVEL P2  
WEST PORTION FLOOR PLAN

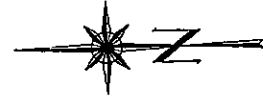

SCALE 1:150

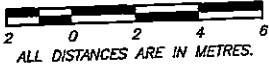

ALL DISTANCES ARE IN METRES.

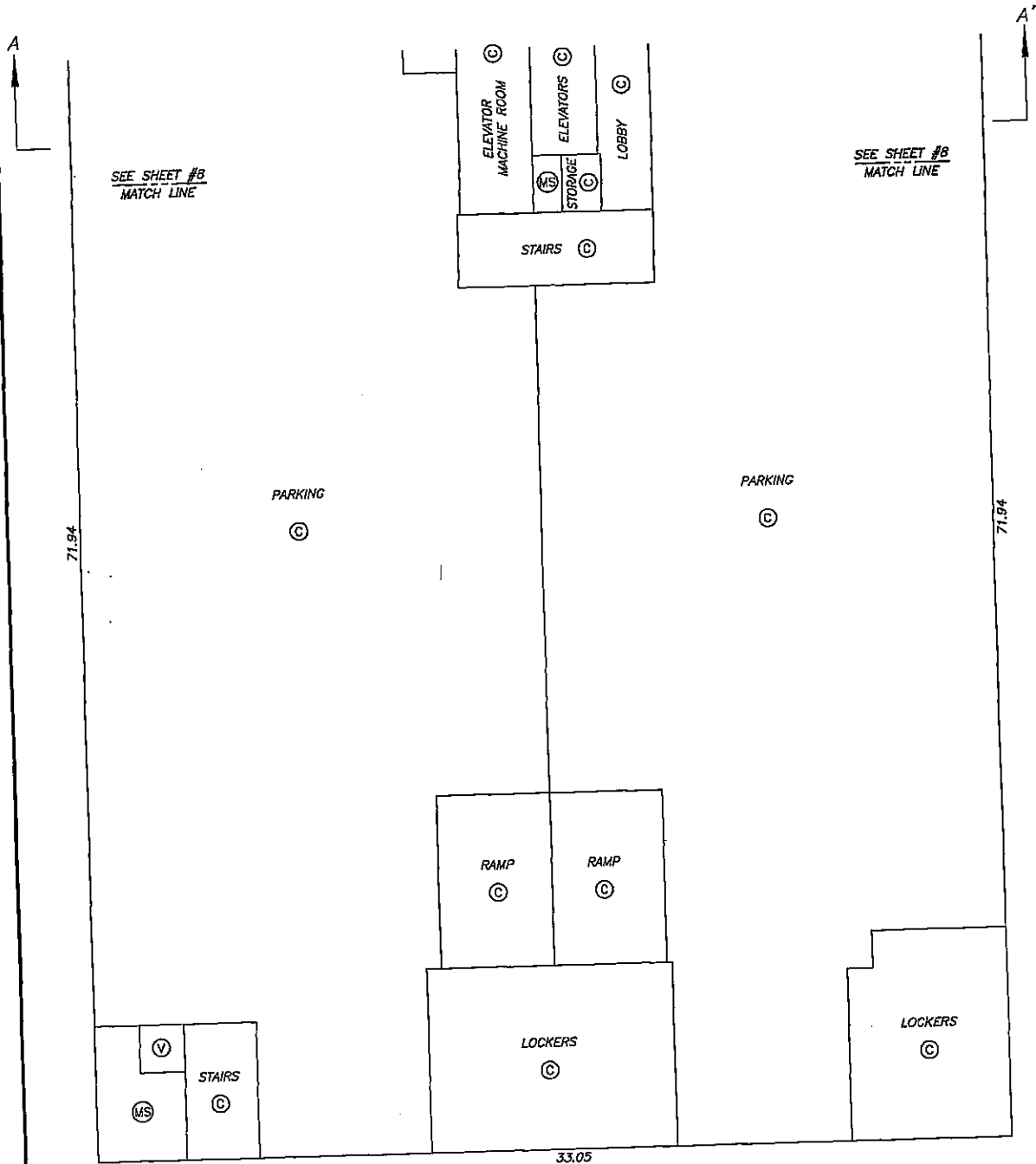

FILED VARS3321 RCD:2009-02-13 PRNT: 2009-03-30-16:11:30.747726

DATE : FEBRUARY 5, 2009

*M.E.B.*

DRAWING # 30578-15  
FILE # 30578-15\_P2

ORIGINAL

# PARKING LEVEL P2 EAST PORTION FLOOR PLAN

STRATA PLAN BCS 3321

SCALE 1:150  
2 0 2 4 6  
ALL DISTANCES ARE IN METRES.



33.05

LOCKERS



WATER  
ENTRY  
ROOM



PARKING



71.94

71.94



MATCH LINE  
SEE SHEET #7

MATCH LINE  
SEE SHEET #7

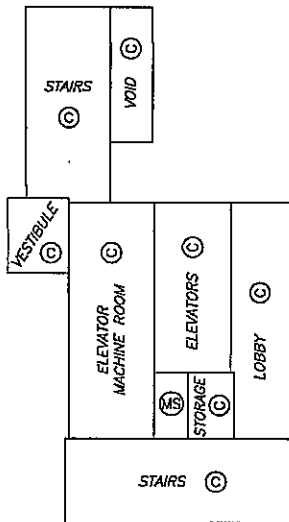

DATE : FEBRUARY 5, 2009

M.E.B.

DRAWING # 30578-15  
FILE # 30578-15\_P2

ORIGINAL

FILED VARGES3321 RCD:2009-02-13 PNT: 2009-03-30-16-11-30.747726

# PARKING LEVEL P1 WEST PORTION

# STRATA PLAN BCS 3321

SCALE 1:150

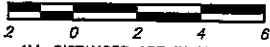

ALL DISTANCES ARE IN METRES.

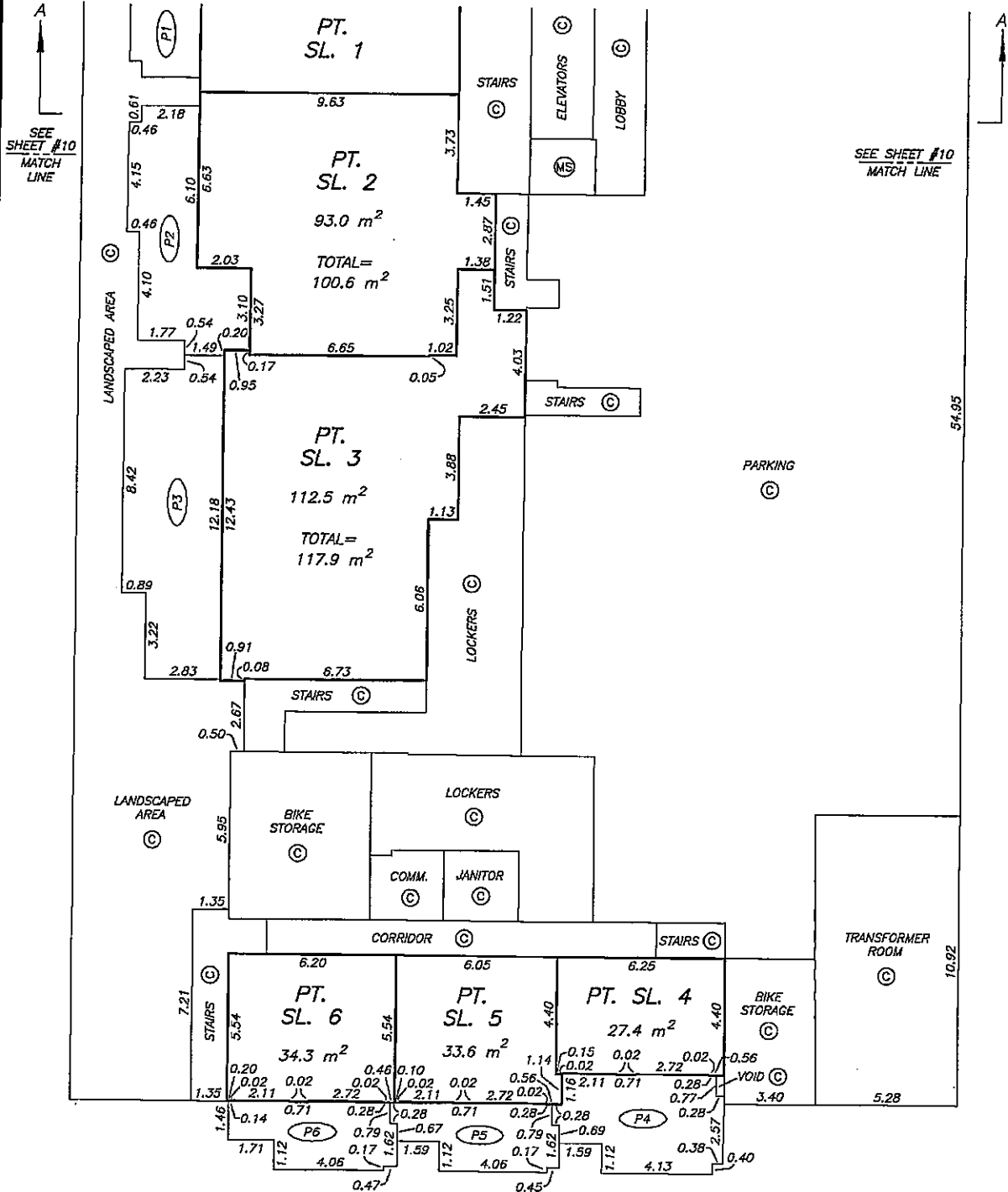
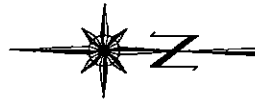

FILED VARGES3321 NC01:2009-02-13 PRINT: 2009-03-30-16:11:30.747726

# PARKING LEVEL P1 EAST PORTION

# STRATA PLAN BCS 3321

SCALE 1:150

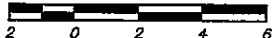

ALL DISTANCES ARE IN METRES.

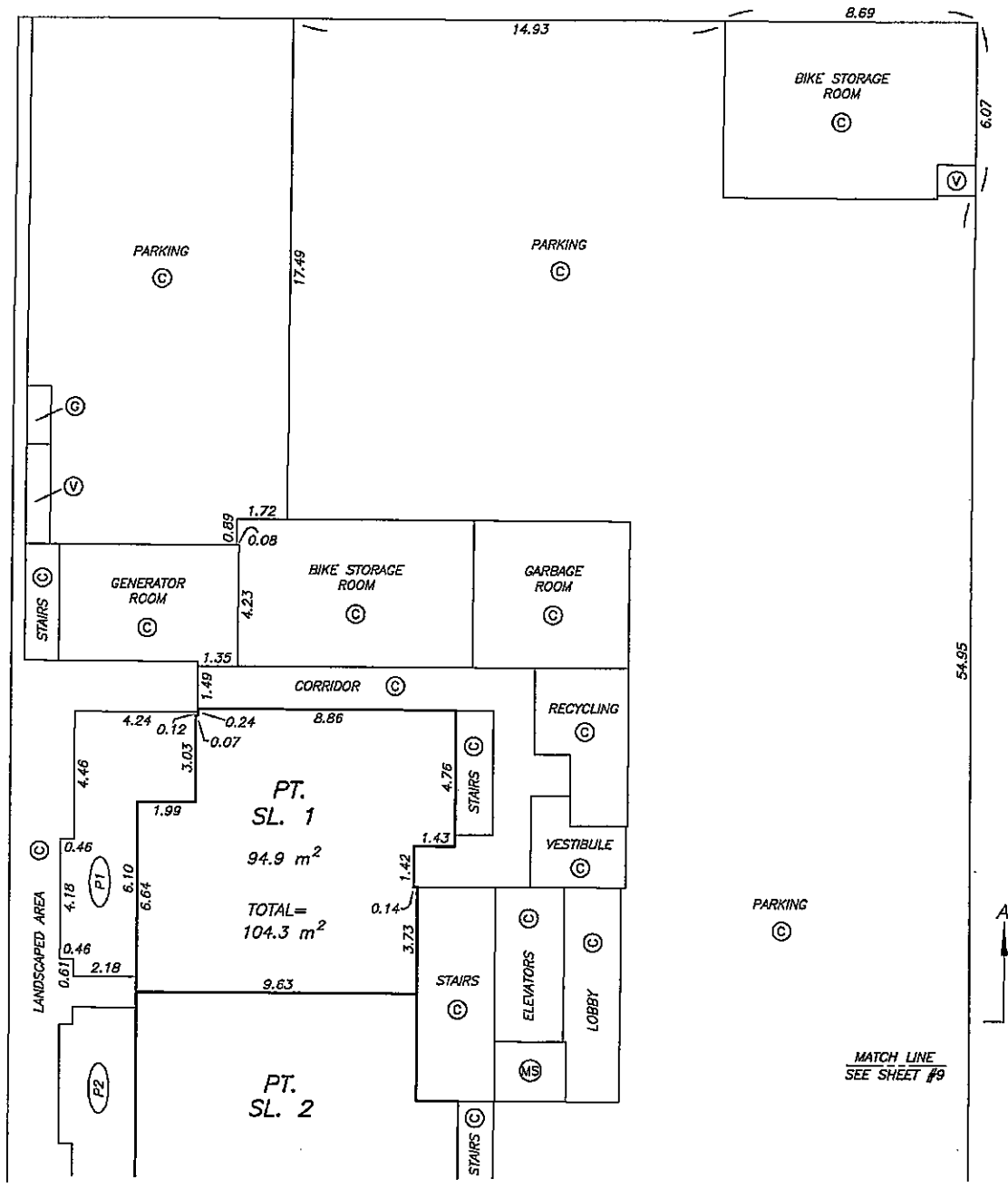
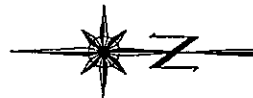

A ↑  
MATCH LINE  
SEE SHEET #9

A' ↑  
MATCH LINE  
SEE SHEET #9

# LEVEL 1 FLOOR PLAN WEST PORTION

# STRATA PLAN BCS 3321

SCALE 1:150



ALL DISTANCES ARE IN METRES.



FILED VARS3321 RCVD:2009-02-13 PRNT: 2009-03-30-16:11:30.747726

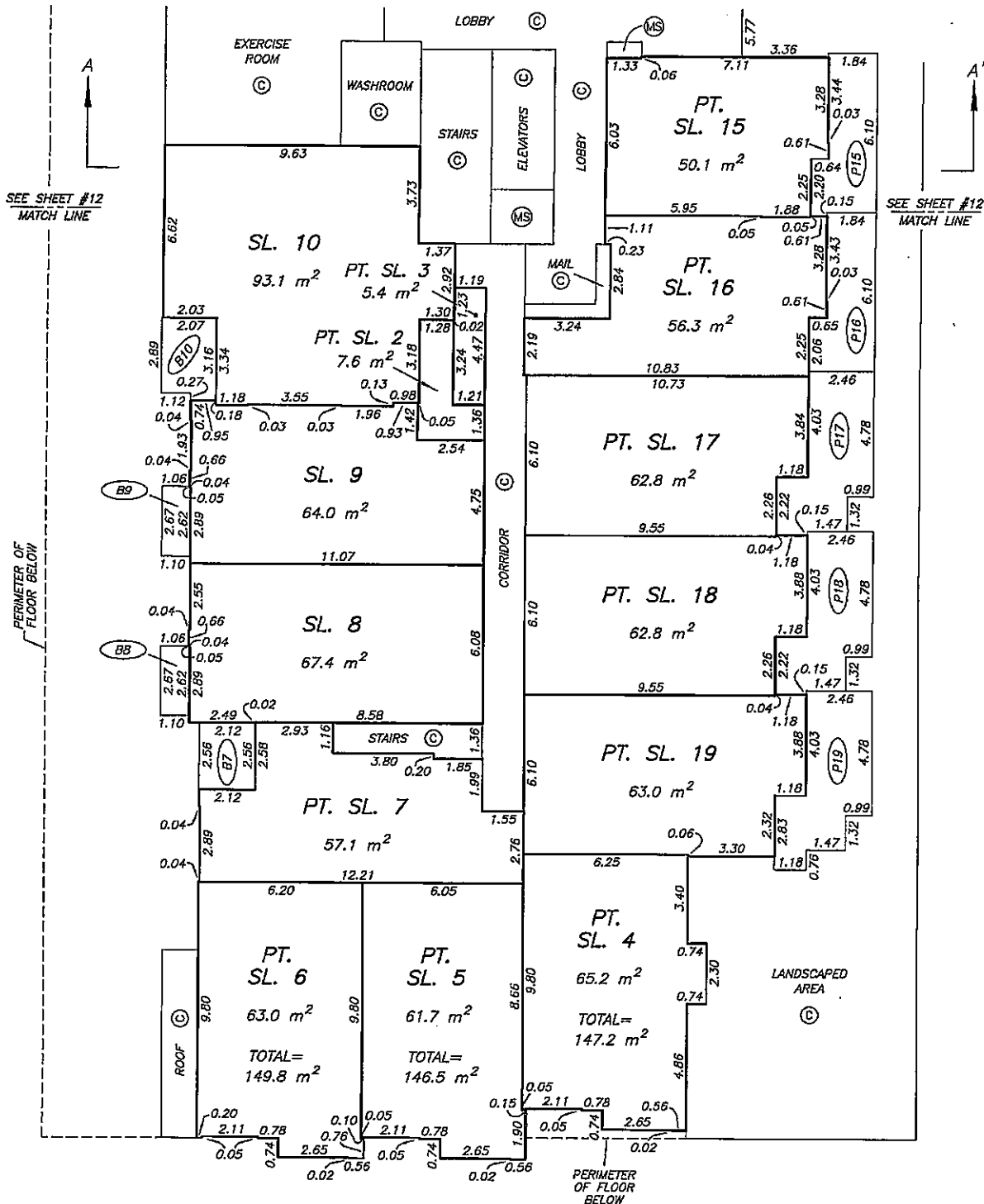

DATE : FEBRUARY 5, 2009

*M.P.B.*

DRAWING # 30578-15  
FILE # 30578-15\_L1

ORIGINAL

# LEVEL 1 FLOOR PLAN EAST PORTION

## STRATA PLAN BCS 3321

SCALE 1:150

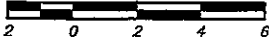

ALL DISTANCES ARE IN METRES.

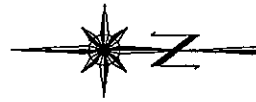

FILED VACCS3321 RCD:2009-02-13 PRINT: 2009-03-30-16:11:30.747726

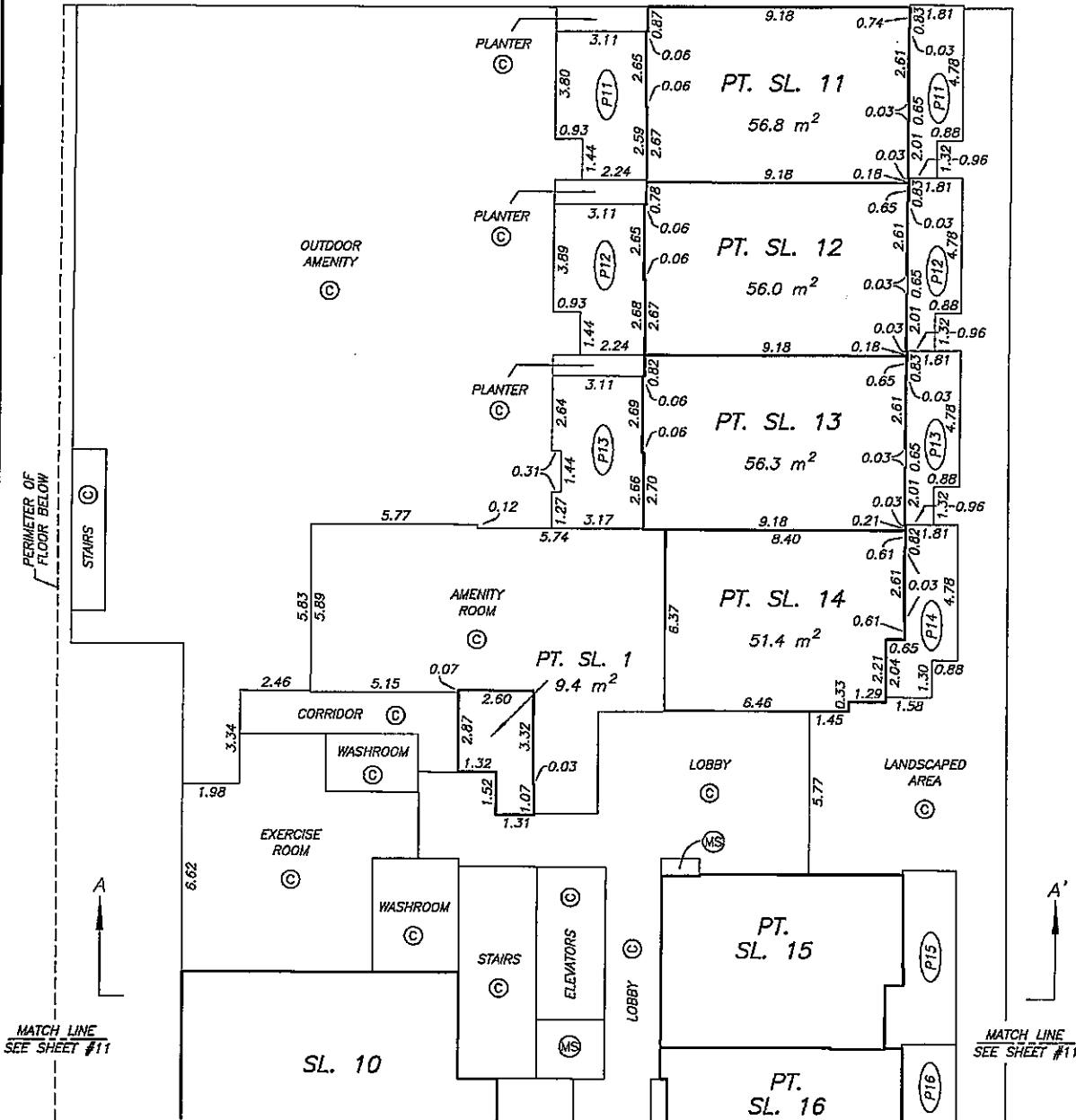

DATE : FEBRUARY 5, 2009

*M. P. B.*

DRAWING # 30578-15  
FILE # 30578-15\_L1

ORIGINAL

# LEVEL 2 FLOOR PLAN WEST PORTION

# STRATA PLAN BCS 3321

SCALE 1:150

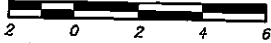

ALL DISTANCES ARE IN METRES.

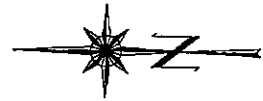

A

A'

SEE SHEET #14  
MATCH LINE

SEE SHEET #14  
MATCH LINE

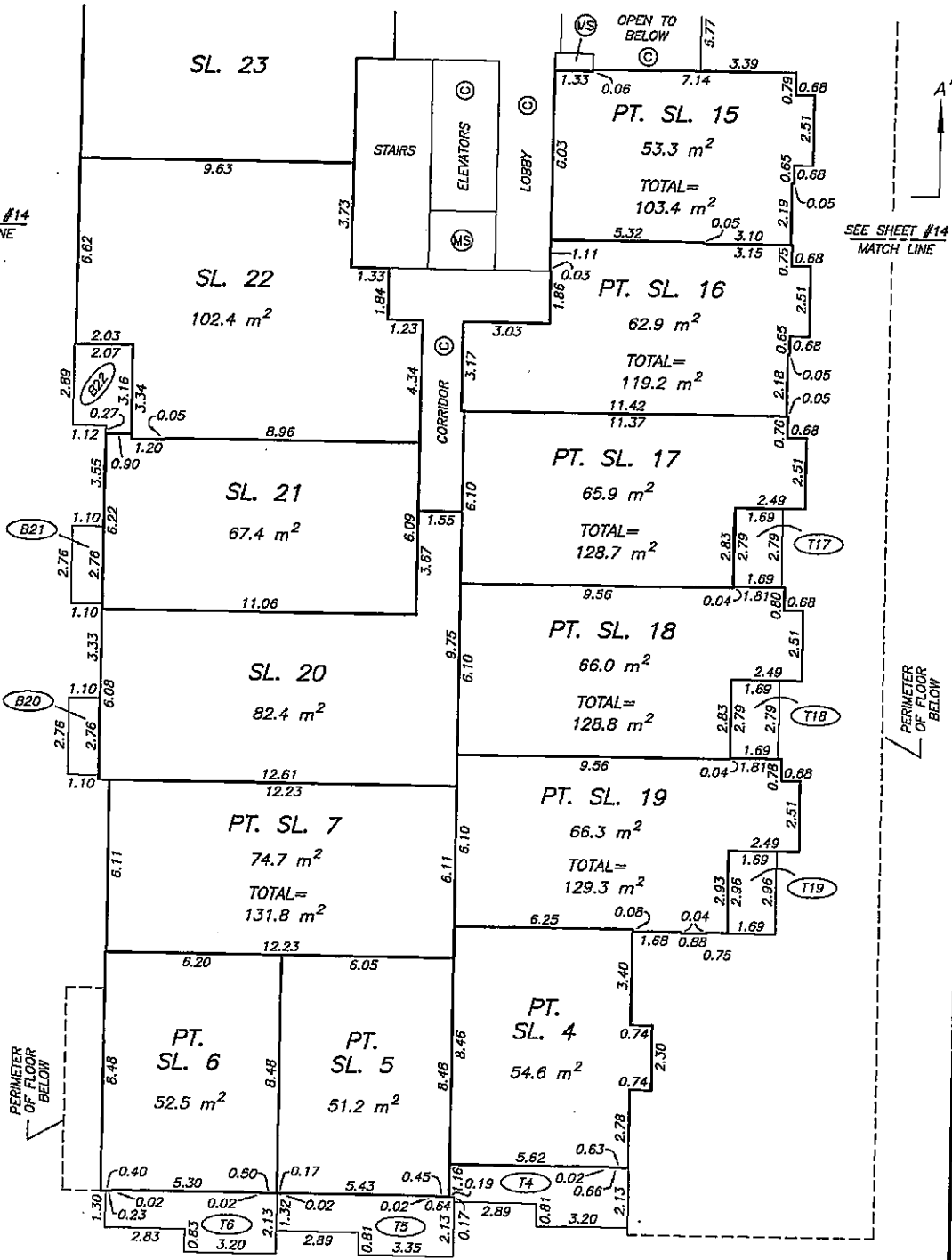

PERIMETER OF FLOOR BELOW

PERIMETER OF FLOOR BELOW

M. P. S.

ORIGINAL

# LEVEL 2 FLOOR PLAN EAST PORTION

# STRATA PLAN BCS 3321

SCALE 1:150

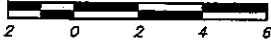

ALL DISTANCES ARE IN METRES.

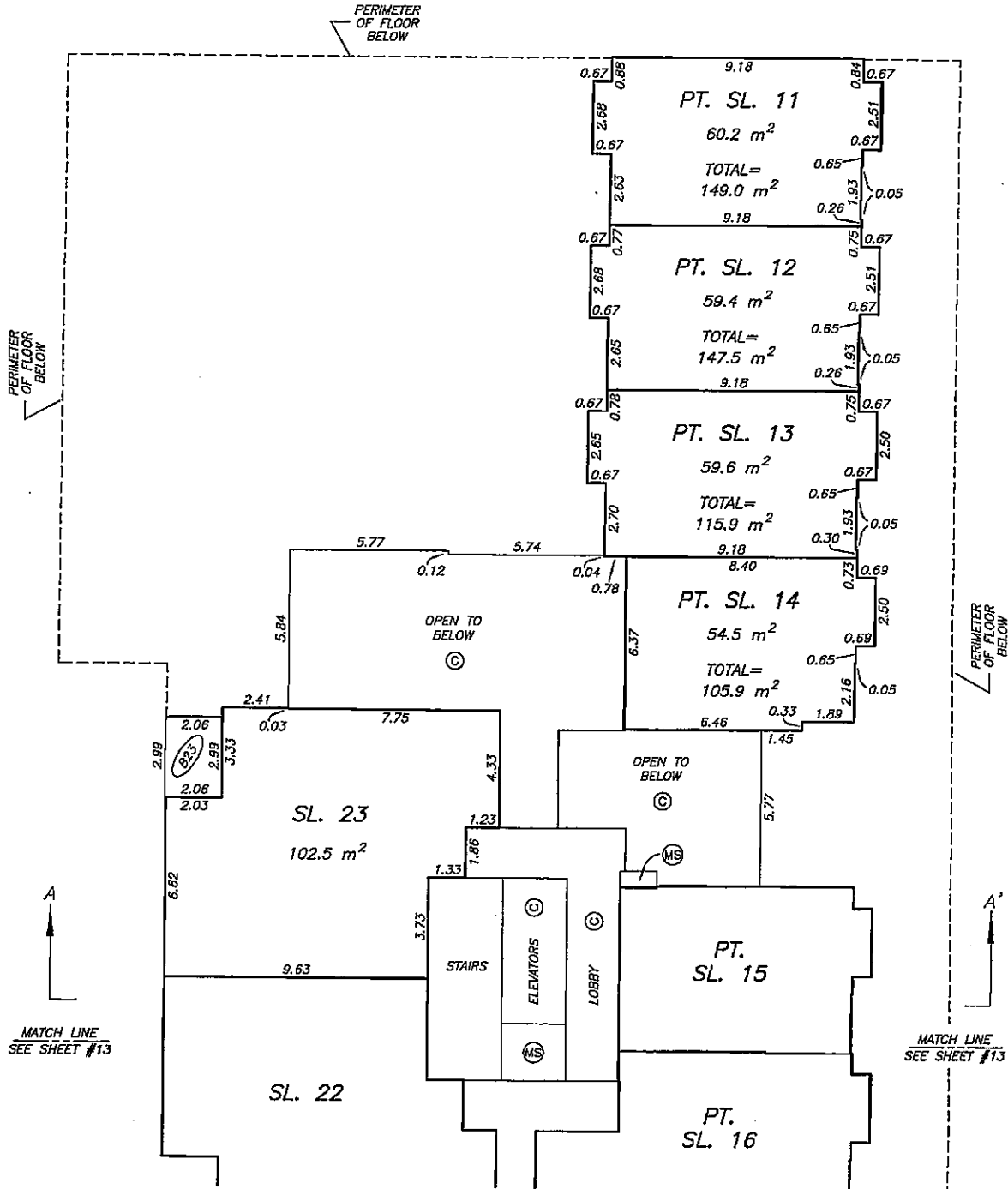

# LEVEL 3 FLOOR PLAN WEST PORTION

## STRATA PLAN BCS 3321

SCALE 1:150

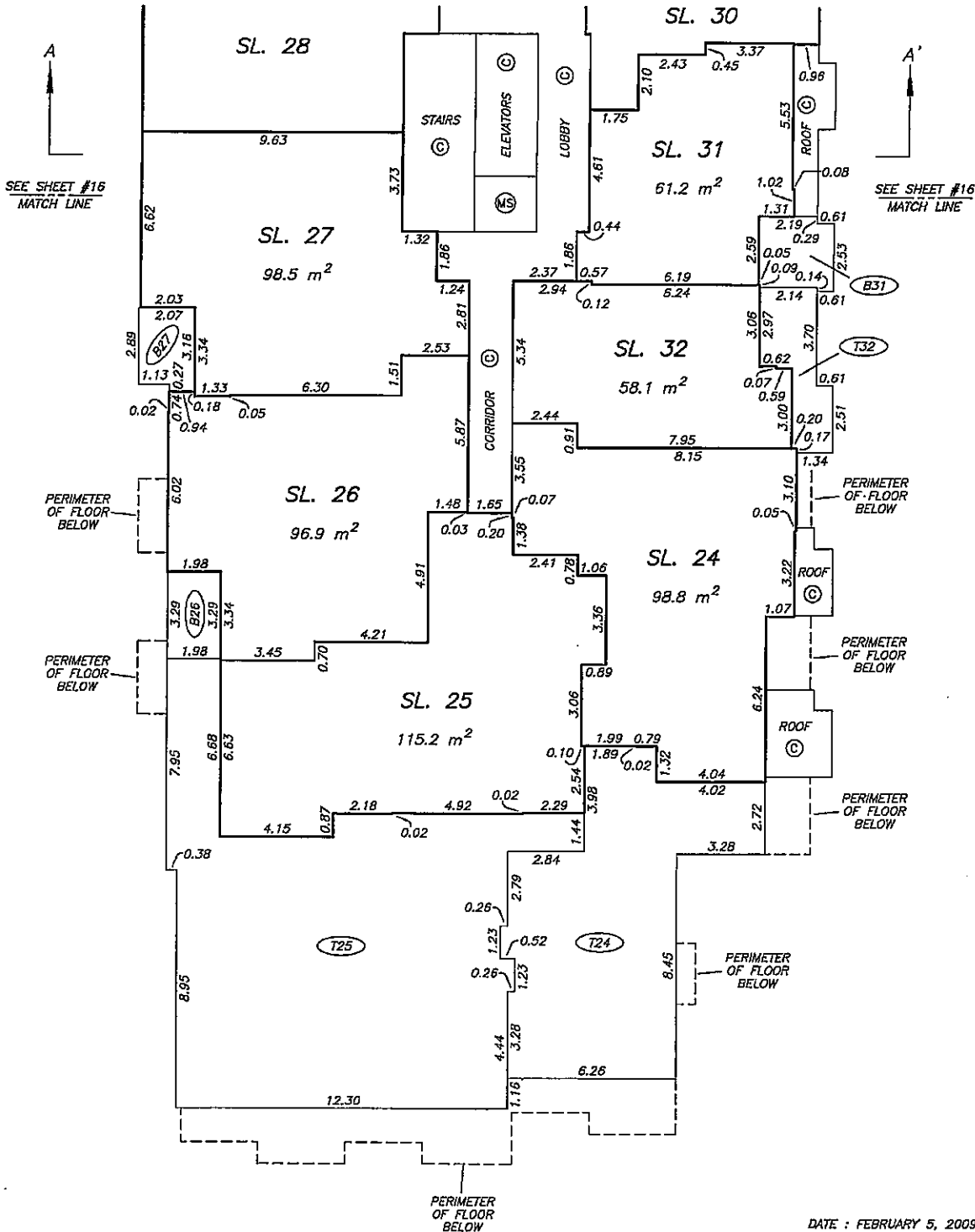
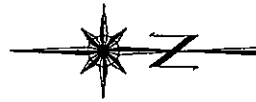
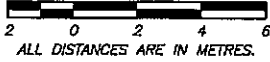

DRAWING # 30578-15  
FILE # 30578-15\_L3

DATE : FEBRUARY 5, 2009

*M.P.S.*

ORIGINAL

FILED VABCS3321 RCD:2009-02-13 PRNT: 2009-03-30-16 11.30.747726

# LEVEL 3 FLOOR PLAN EAST PORTION

## STRATA PLAN BCS 3321

SCALE 1:150

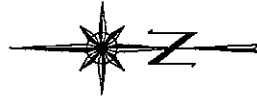
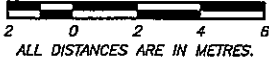

FILED  
 VABCS3321  
 RCMD:2009-02-13  
 PRINT: 2009-03-30-16:11:30.747726

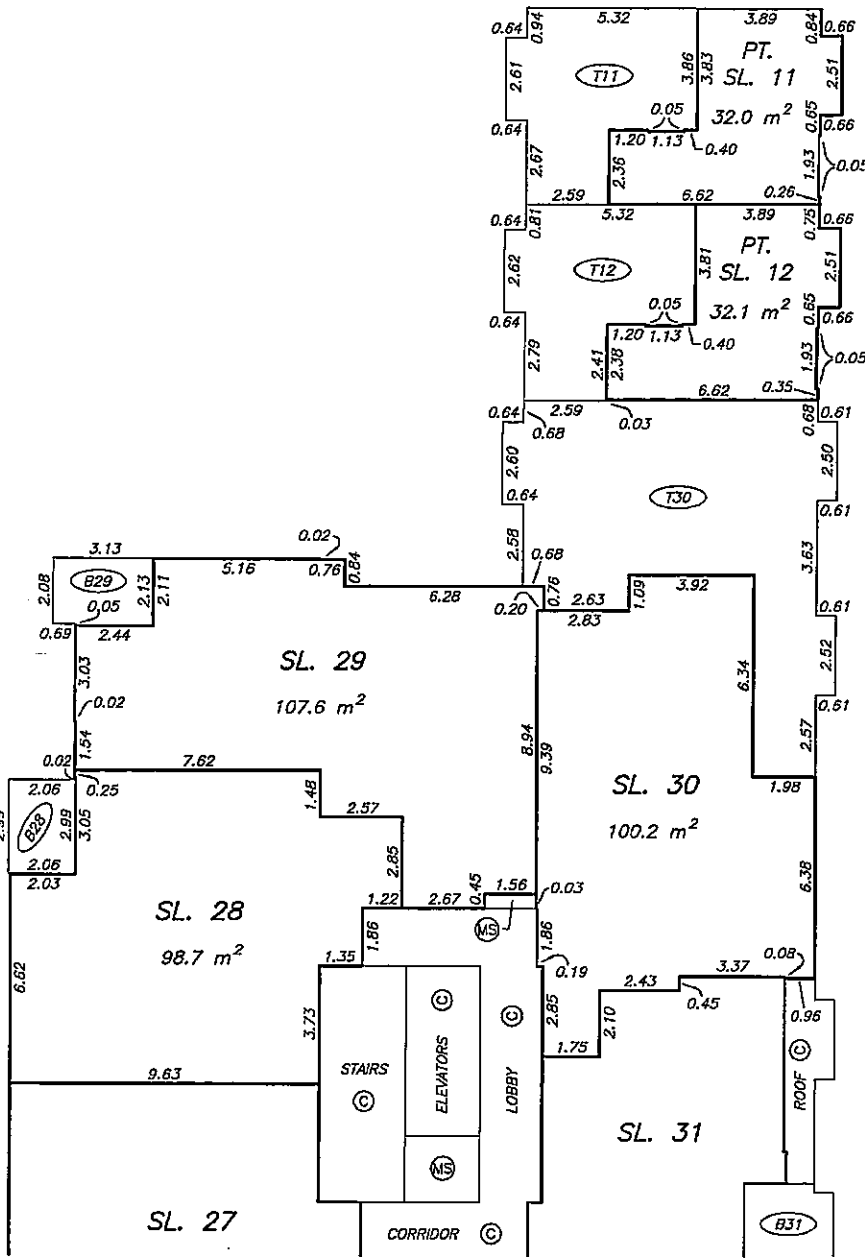

MATCH LINE  
 SEE SHEET #15

MATCH LINE  
 SEE SHEET #15

*M.C.B.*

ORIGINAL

# LEVEL 4 FLOOR PLAN

## STRATA PLAN BCS 3321

SCALE 1:150

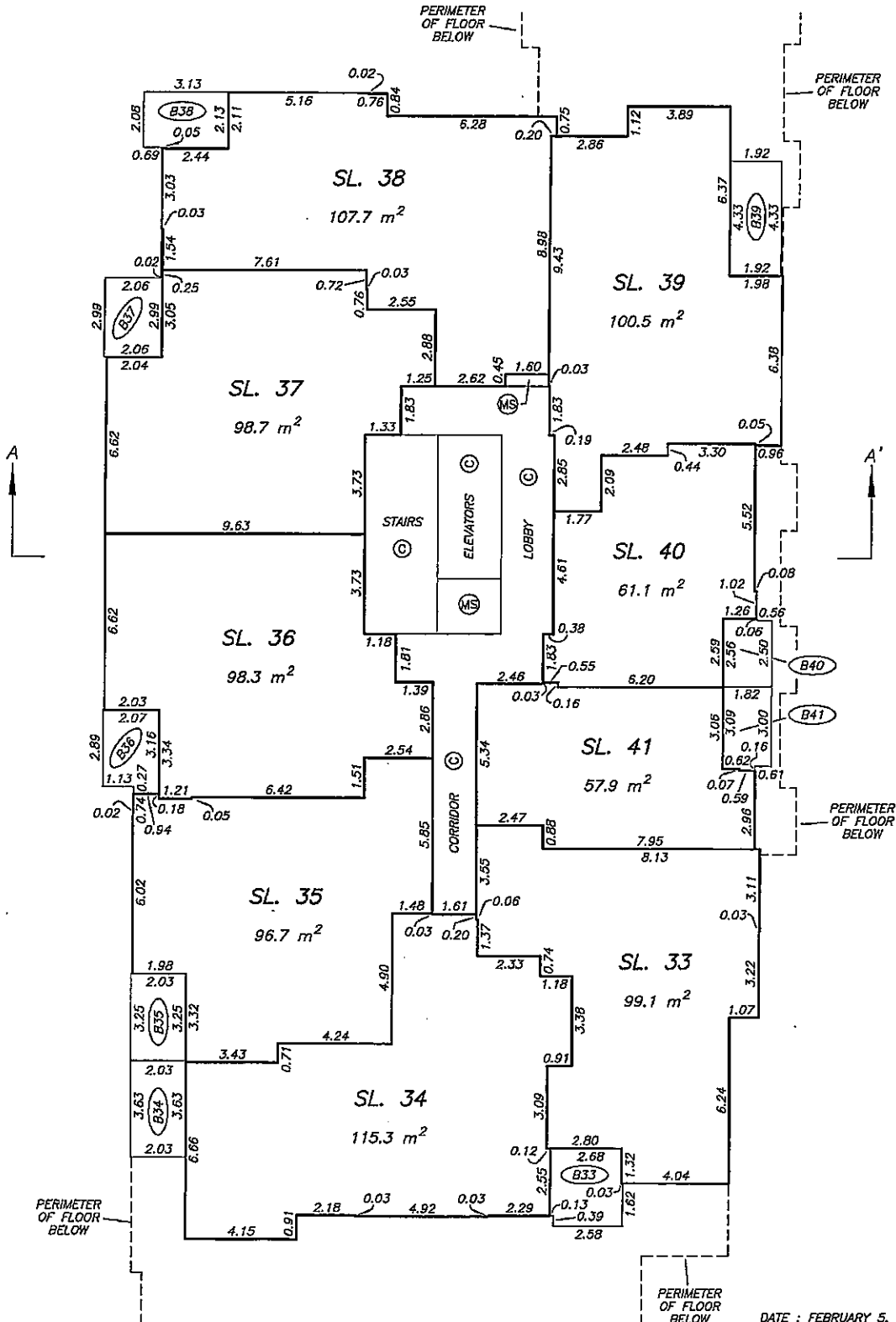
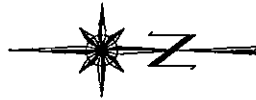
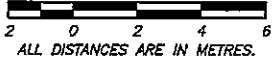

DRAWING # 30578-15  
FILE # 30578-15\_14

DATE : FEBRUARY 5, 2009

*M. P. S.*

ORIGINAL

FILED VARGCS3321 RCD:2009-02-13 PRINT: 2009-03-30-16.11.30.747226

# LEVEL 5 FLOOR PLAN

# STRATA PLAN BCS 3321

SCALE 1:150

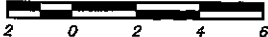

ALL DISTANCES ARE IN METRES.

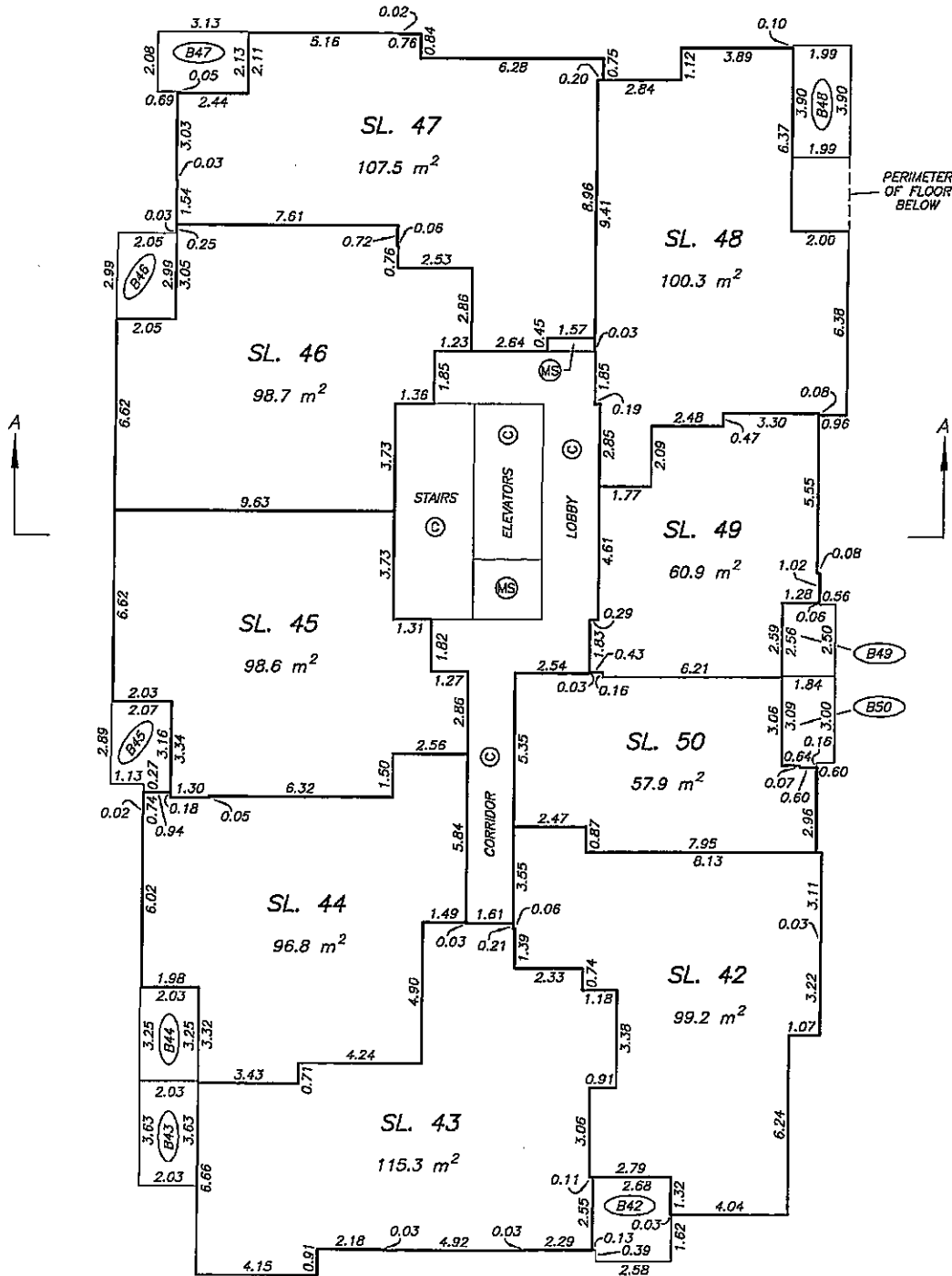

PERIMETER OF FLOOR BELOW

DATE : FEBRUARY 5, 2009

*M. E. S.*

DRAWING # 30578-15  
FILE # 30578-15\_L5

ORIGINAL

FILED VARS3321 RCD:2009-02-13 PRT: 2009-03-30-16:11:30.747726

# LEVEL 6 FLOOR PLAN

## STRATA PLAN BCS 3321

SCALE 1:150

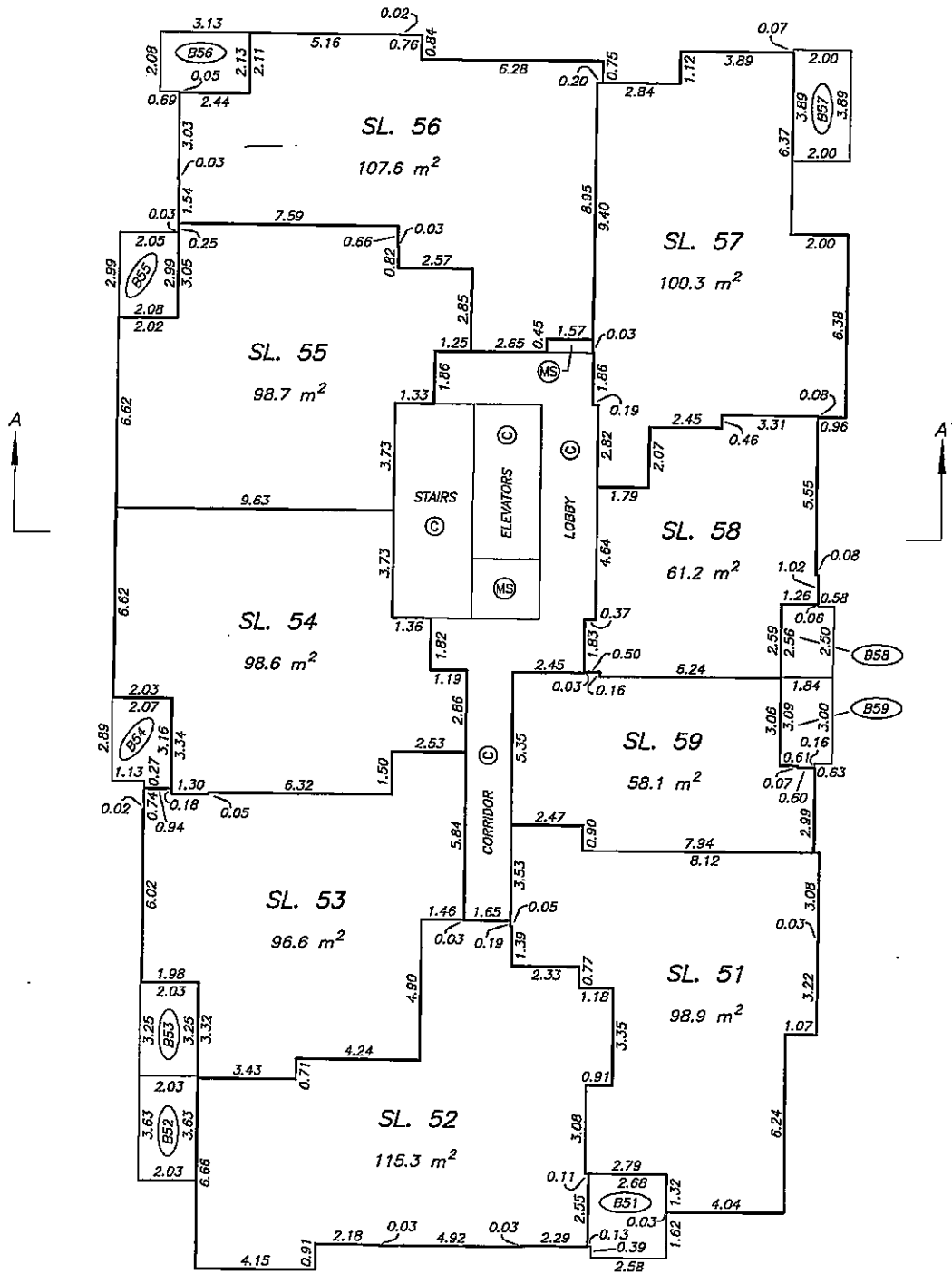
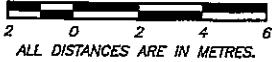

FILED VBCS3321 RCD:2009-02-13 PRINT: 2009-03-30-16.11.30.747726

*M. P. S.*

ORIGINAL

# LEVEL 7 FLOOR PLAN

## STRATA PLAN BCS 3321

SCALE 1:150

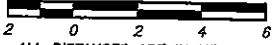

ALL DISTANCES ARE IN METRES.

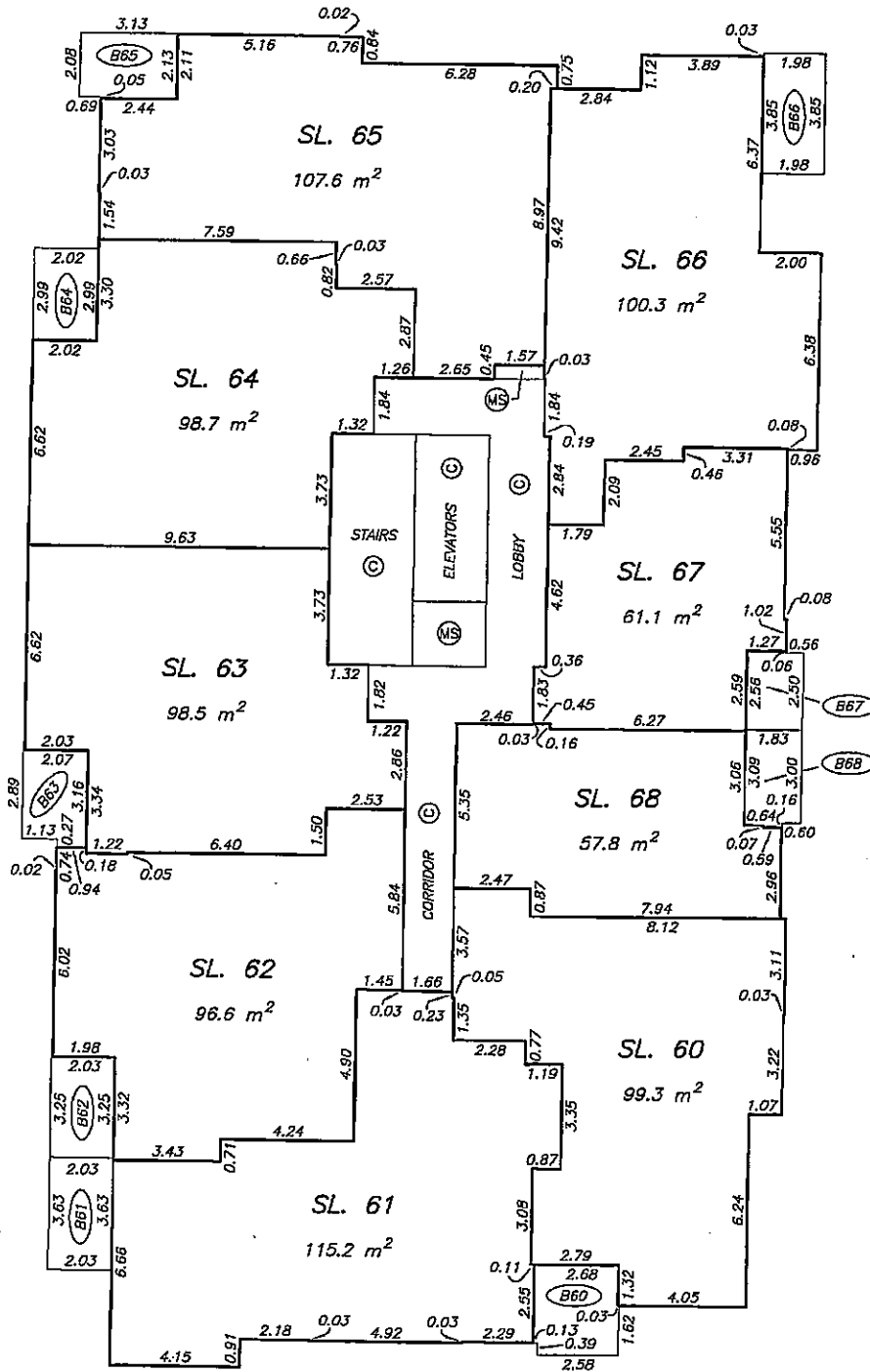



# LEVEL 9 FLOOR PLAN

## STRATA PLAN BCS 3321

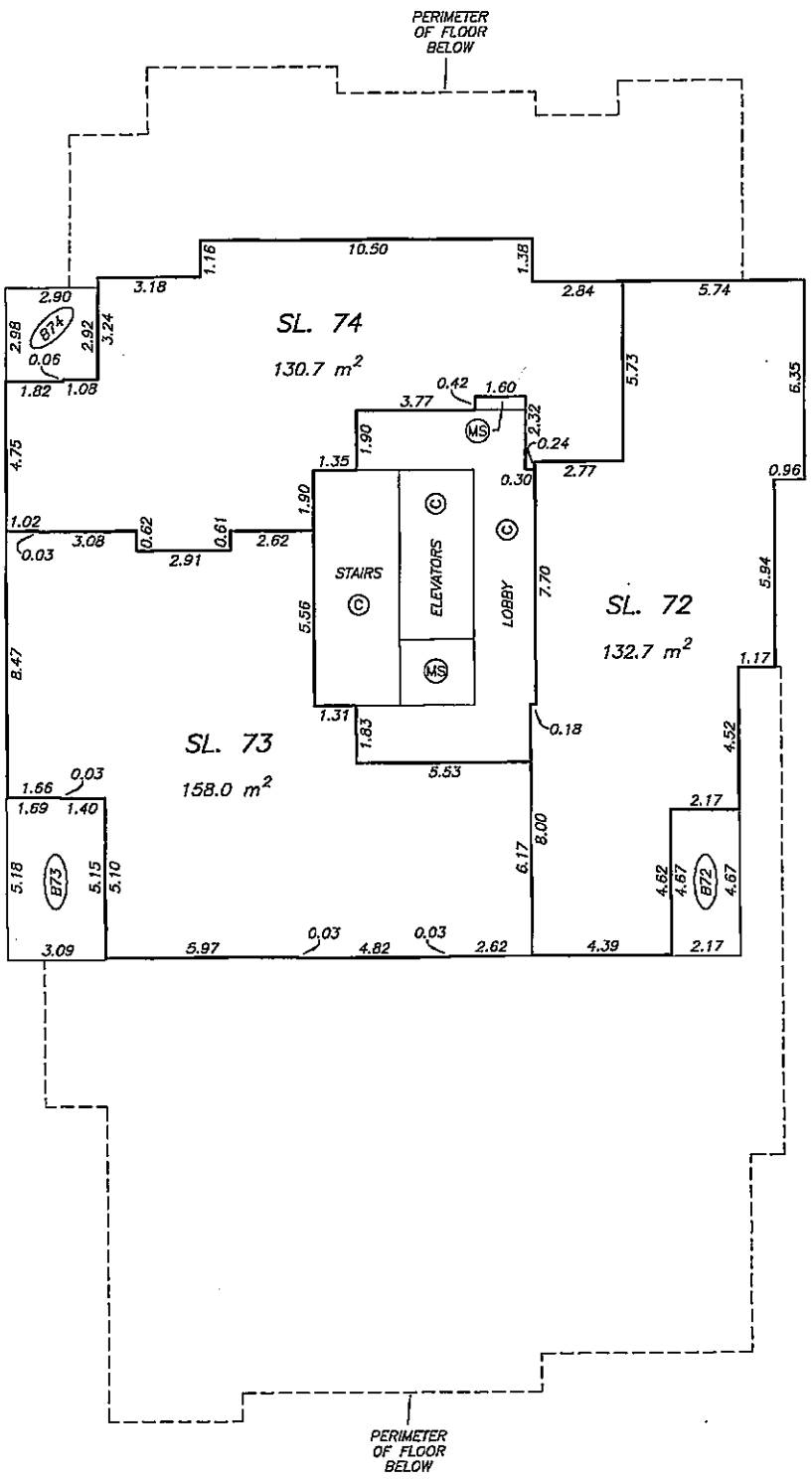
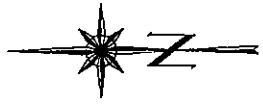
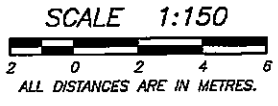

DATE : FEBRUARY 5, 2009  
M.E.S.

ORIGINAL

FILED  
VAUCS3321  
RCO:2009-02-13  
PRINT: 2009-03-30-16.11.30.747726

# LEVEL 11 FLOOR PLAN

# STRATA PLAN BCS 3321

SCALE 1:150

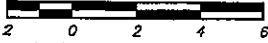

ALL DISTANCES ARE IN METRES.

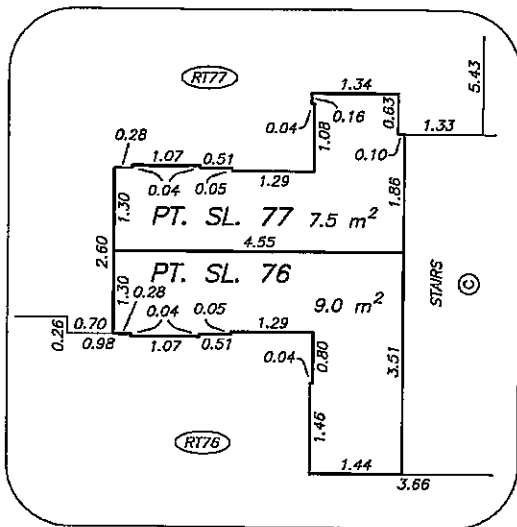
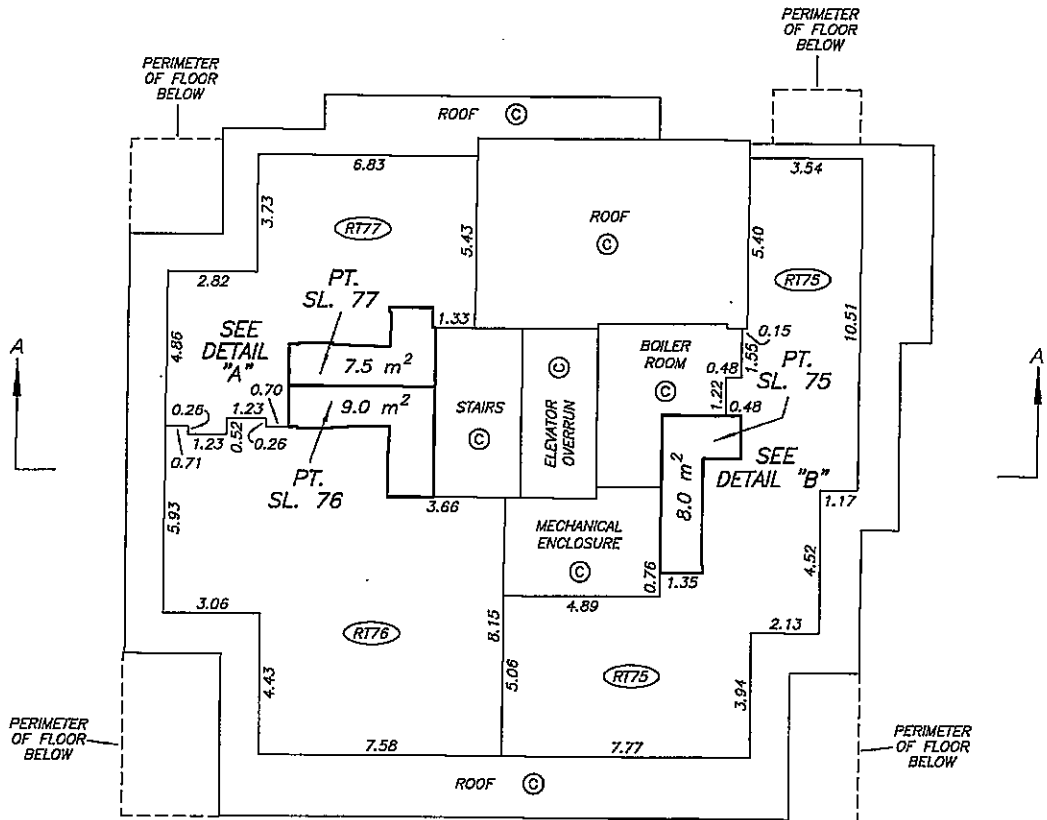
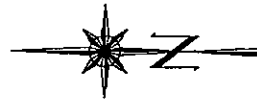

**DETAIL "A"**

NOT TO SCALE

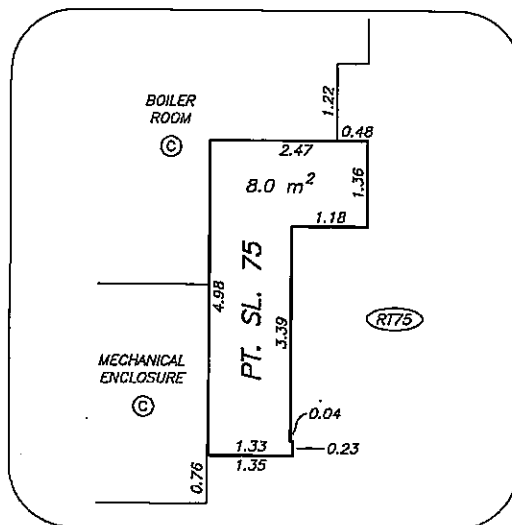

**DETAIL "B"**

NOT TO SCALE