

SCALE 1: 250



All dimensions are in metres.

STRATA PLAN LMS 4410

E. 39th Ave

Lane

Victoria Drive

Concrete foundation
(Parkade level)

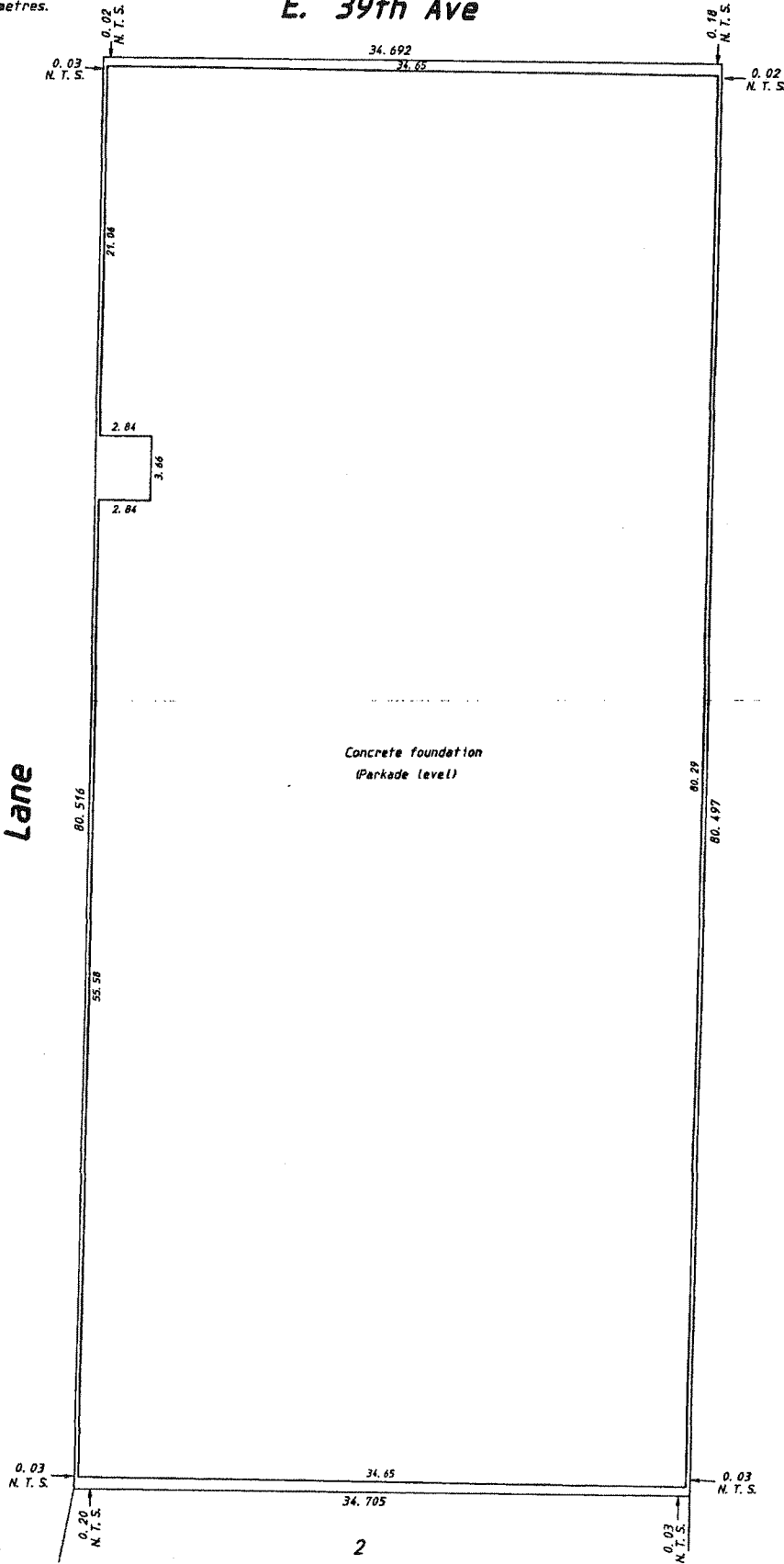

DHALIWAL OLIVER WONG
 PROFESSIONAL LAND SURVEYING INC.
 121-13140 80th Avenue
 Surrey, B.C.
 V3W 3B2
 (ph) 501-6188
 (fx) 501-6189
 File: 9810012.S72

2
 PLAN 13918

DATE: MAR 20/01 *[Signature]* B.C.L.S.

FILED
 LMS4410
 S57641 2005-12-30-11:00:20.203252

SCALE 1: 250



All dimensions are in metres.

STRATA PLAN LMS 4410

PARKADE LEVEL

E. 39th Ave



0.20 Perimeter Concrete wall (CP)

Lane

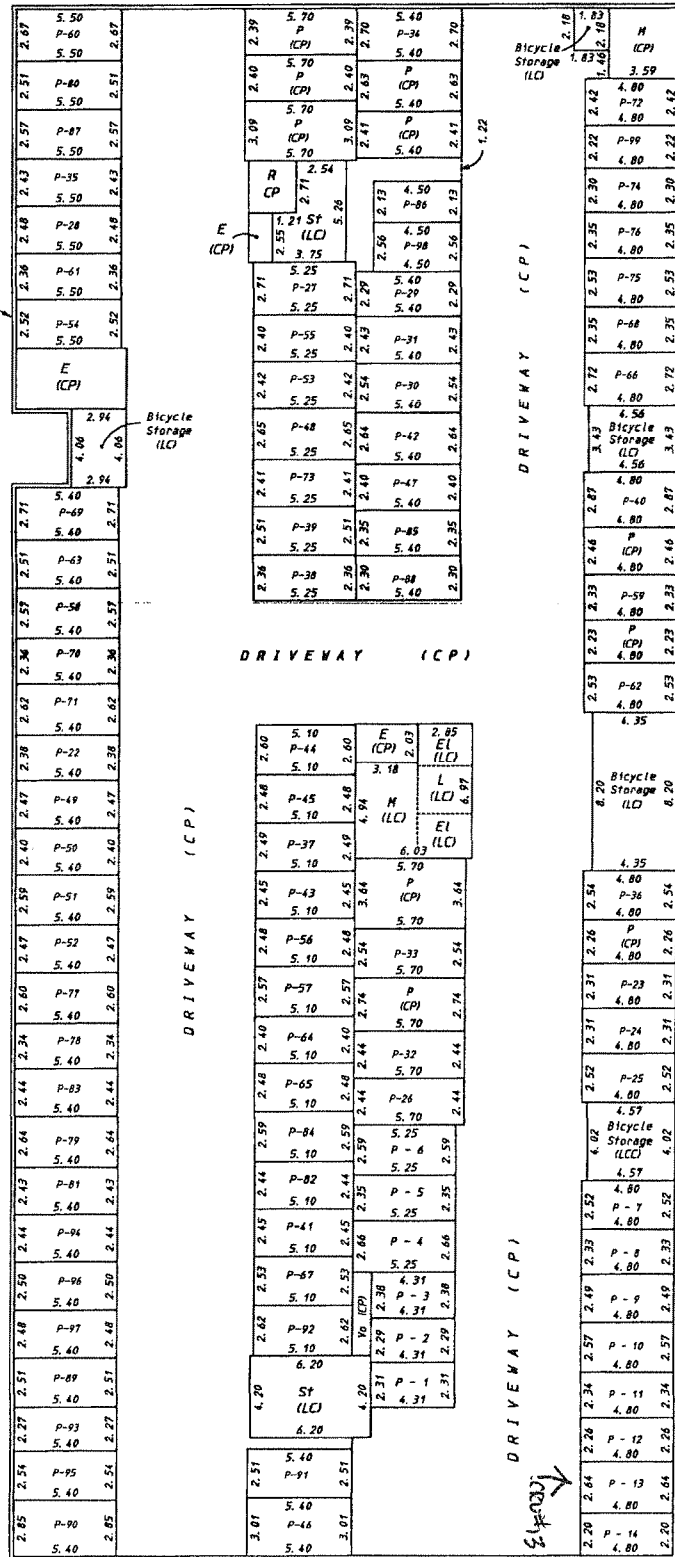

DHALIHAL OLIVER WONG
 PROFESSIONAL LAND SURVEYING INC.
 121-13140 80th Avenue
 Surrey, B.C.
 V3M 3B2
 (ph) 501-6188
 (fx) 501-6189
 F110: PARKADE, FLR

DATE: MAR 20/04 B.C.L.S.

SCALE 1: 250

SHEET 4 OF 8 SHEETS



All dimensions are in metres.

STRATA PLAN LMS 4410

GROUND LEVEL

E. 39th Ave

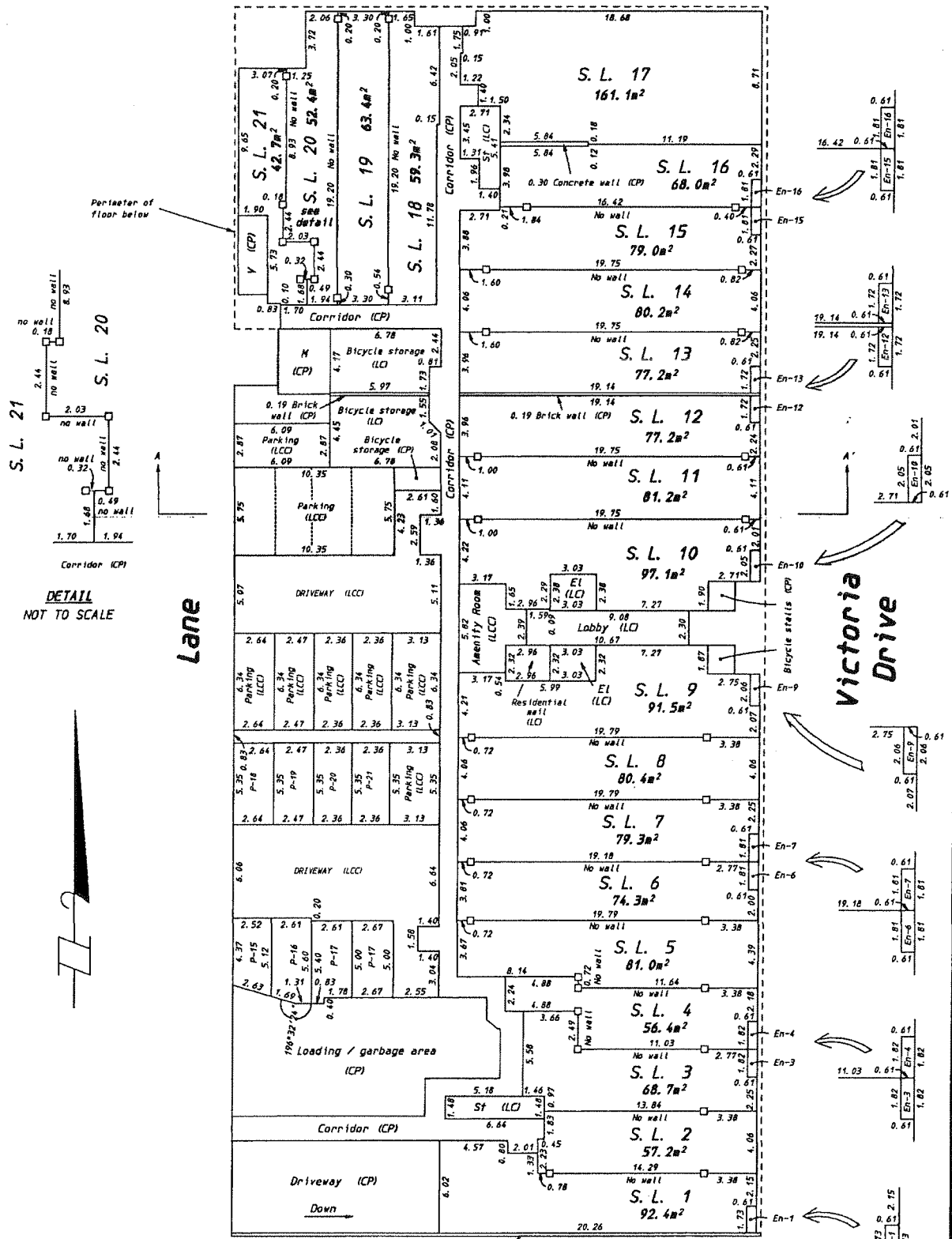

DHALIHAL OLIVER WONG
 PROFESSIONAL LAND SURVEYING INC.
 121-13140 80th Avenue
 Surrey, B.C.
 V3W 3B2
 (ph) 501-6188
 (fx) 501-6189
 File: FIRST.FLR

DATE: MAR 20/01 *[Signature]* B.C.L.S.

FILED LINC034940 2003-09-17 11:00:40.203252

SCALE 1: 250

SHEET 5 OF 8 SHEETS



All dimensions are in metres.

STRATA PLAN LMS 4410

SECOND FLOOR

E. 39th Ave

Perimeter of floor below

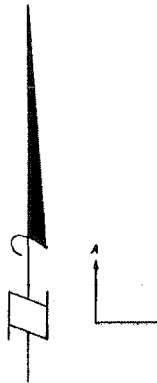

Lane

Victoria Drive

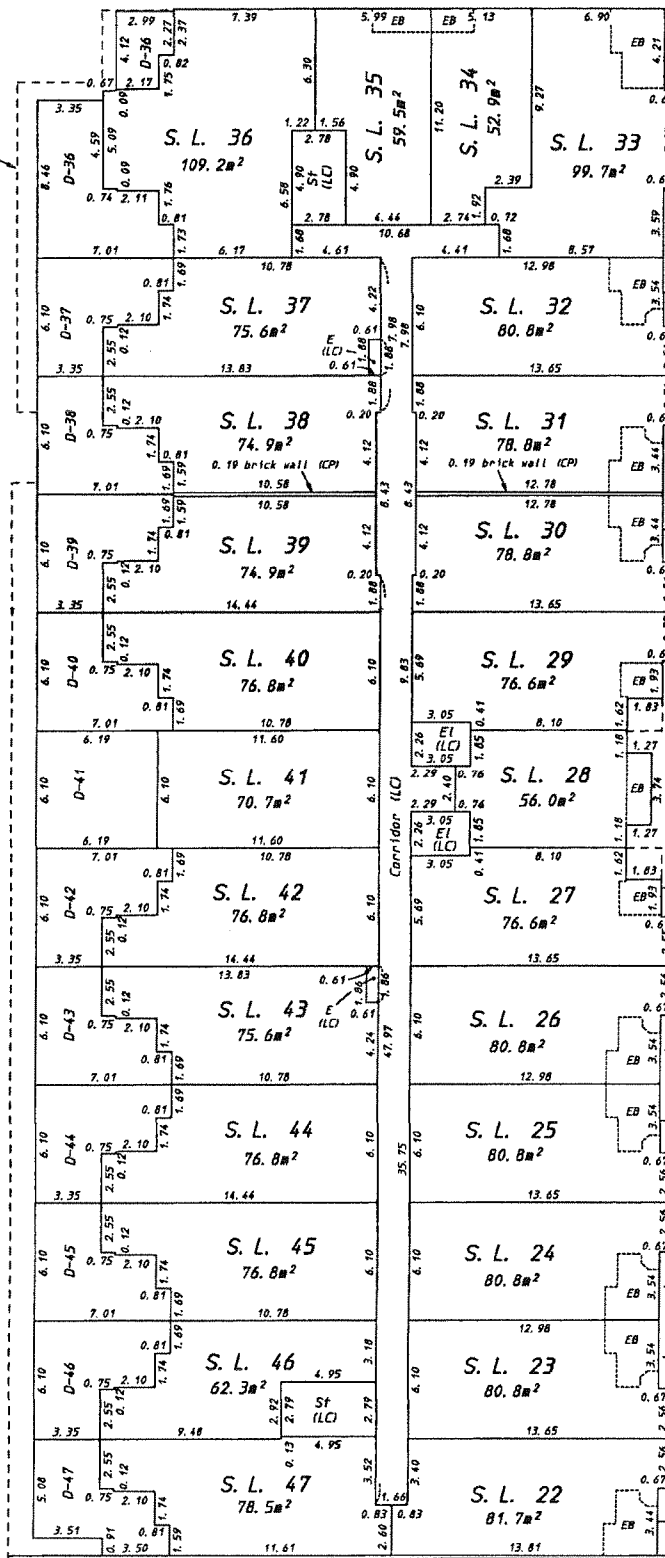

DHALIHAL OLIVER WONG
 PROFESSIONAL LAND SURVEYING INC.
 121-13140 80th Avenue
 Surrey, B.C.
 V3W 3B2
 (ph) 501-6188
 (fx) 501-6189
 File: second.flr

DATE: MAR 20/01 *[Signature]* B.C.L.S.

FILED LMS4410 552691 2005-12-30-11:00:20 2003252

SCALE 1:250



All dimensions are in metres.

STRATA PLAN LMS 4410

THIRD FLOOR

E. 39th Ave

Perimeter of floor below

Lane

Victoria Drive

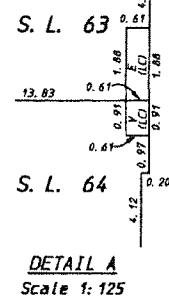
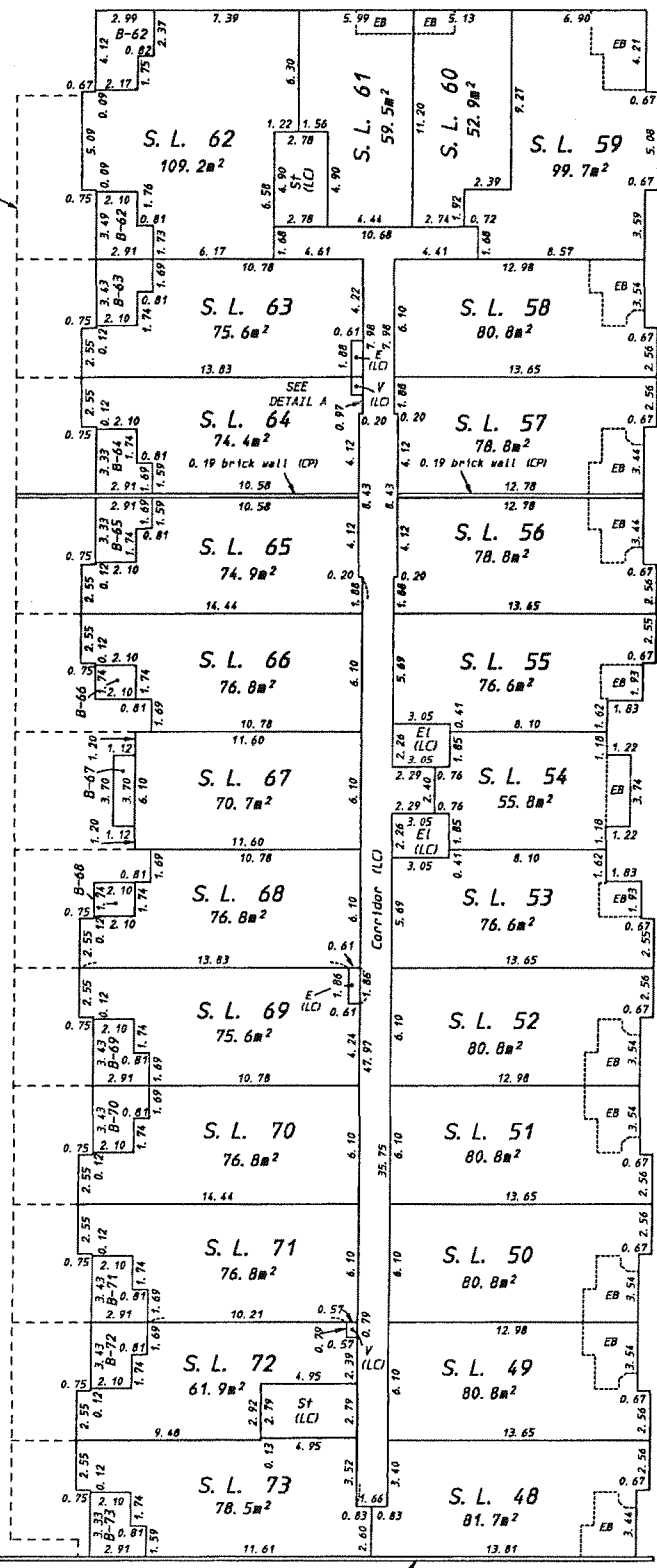

DHALINAL OLIVER WONG
 PROFESSIONAL LAND SURVEYING INC.
 121-13140 80th Avenue
 Surrey, B.C.
 V3W 3B2
 (ph) 501-6188
 (fx) 501-6189
 File: Third.F1P

0.20 Concrete wall (CP)

DATE: MAR 20/01 *fas* B.C.L.S.

SCALE 1:250



All dimensions are in metres.

STRATA PLAN LMS 4410

FOURTH FLOOR

E. 39th Ave

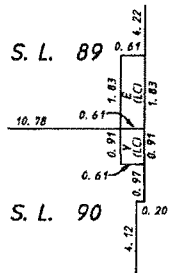
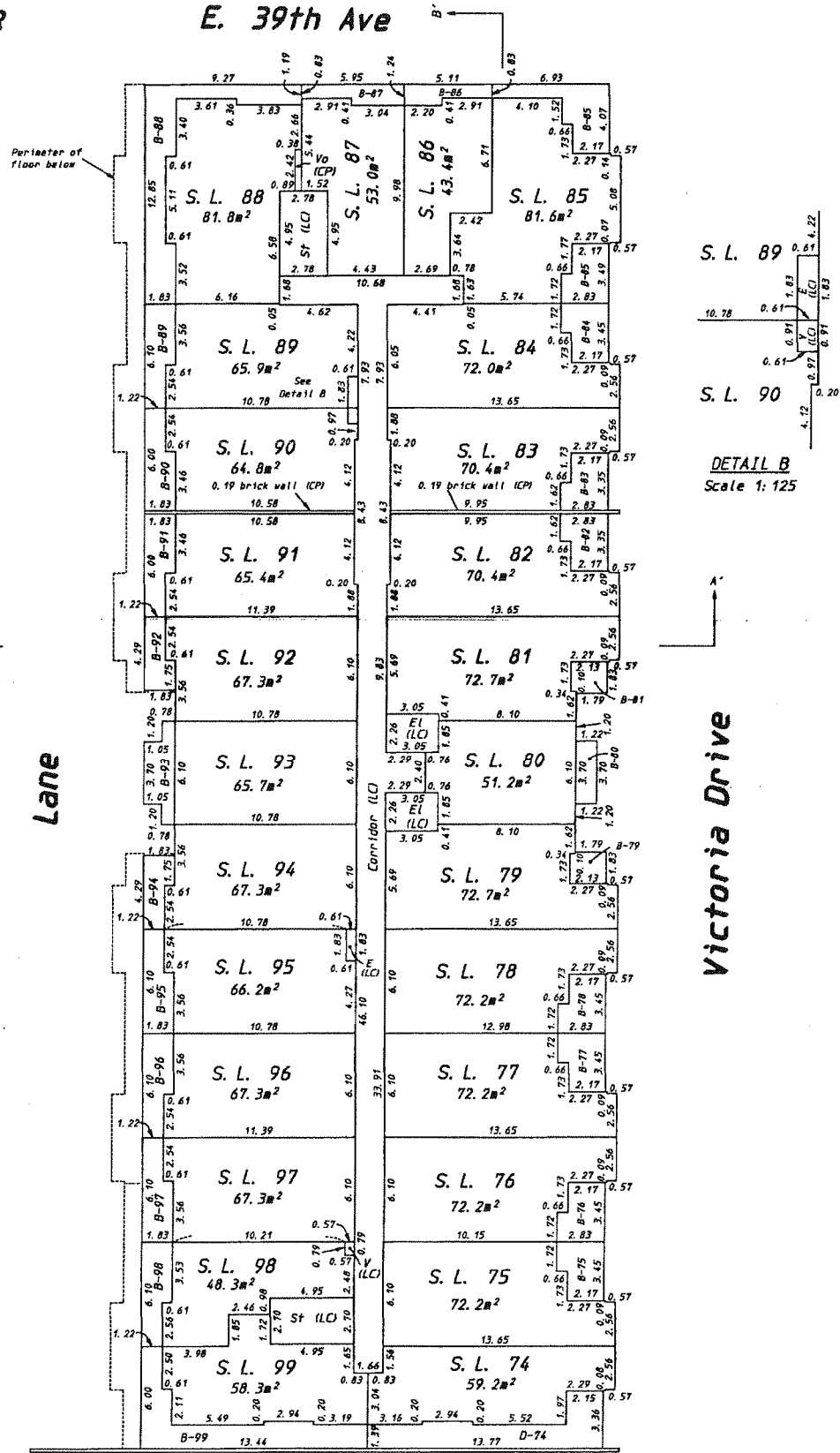

DETAIL B
Scale 1:125

DHALIWA OLIVER WONG
 PROFESSIONAL LAND SURVEYING INC.
 121-13140 80th Avenue
 Surrey, B.C.
 V3W 3B2
 (ph) 501-6188
 (fx) 501-6189
 File: Fourth flr

0.20 Concrete wall (ICP)

DATE: MAR 20/04 *[Signature]* B. C. L. S.

