

582  
Strata Plan  
11.06.13.

**STRATA PLAN OF LOT H, BLOCK 7  
OF BLOCK E, DISTRICT LOT 183,  
PLAN 22848**

FIRST SHEET, SHEET 1 OF 14 SHEETS

09

**B.C.S.S. 826.025  
CITY OF VANCOUVER**

**STRATA PLAN LMS 582**

DEPOSITED AND REGISTERED IN THE LAND  
TITLE OFFICE AT NEW WESTMINSTER, B.C.  
THIS 20<sup>TH</sup> DAY OF OCTOBER, 1982

*[Signature]*  
Deputy REGISTRAR  
BF 401041 - BF 401079

RECEIVED  
NOV 06 2013

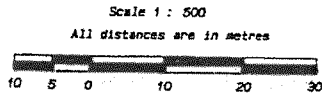

**LEGEND**

BEARINGS ARE GRID BEARINGS AND ARE DERIVED  
FROM CONTROL POINTS 1-1713 AND 1-1841

- SL DENOTES STRATA LOT
- LCP DENOTES LIMITED COMMON PROPERTY
- PT DENOTES PART
- m<sup>2</sup> DENOTES SQUARE METRES
- ⊕ DENOTES BALCONY
- ⊙ DENOTES COMMON PROPERTY
- ⊚ DENOTES PARKING STALL

**CIVIC ADDRESS:**

"GEORGIA COURT"  
1823 EAST GEORGIA STREET  
VANCOUVER, B.C.

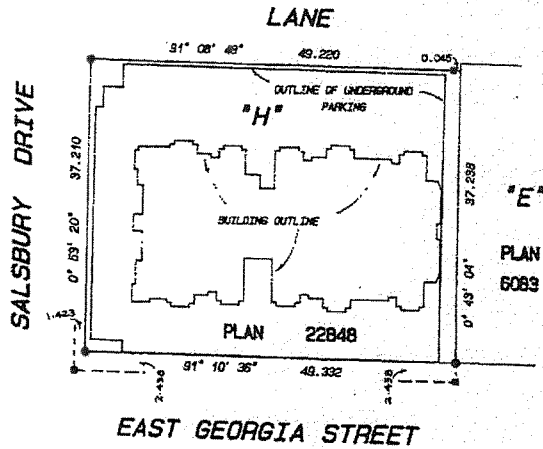

THE ADDRESS FOR SERVICE OF  
DOCUMENTS ON THE STRATA  
CORPORATION IS:  
THE OWNERS, STRATA PLAN LMS 582  
1102 WEST 8TH AVENUE  
VANCOUVER, B.C. V6H 2N5

THIS STRATA PLAN CONTAINS LIMITED  
COMMON PROPERTY UNDER SECTION 53 (2)  
OF THE CONDOMINIUM ACT.

I, ROBERT G. FLYNN OF LADNER, B.C., BRITISH  
COLUMBIA LAND SURVEYOR, HEREBY CERTIFY THAT  
THE BUILDING ERECTED ON THE PARCEL DESCRIBED  
ABOVE IS WHOLLY WITHIN THE EXTERNAL BOUNDARIES  
OF THAT PARCEL. DATED AT VANCOUVER, B. C.  
THIS 14TH DAY OF SEPTEMBER, 1982.

**LYNN FLYNN & ASSOCIATES**  
Professional Land Surveyors  
#102 - 1537 W. 6th Avenue  
Vancouver, B.C. V6J 1T5  
Tel: 737-8777 Fax: 737-8794  
FILE: 89-2970

THIS PLAN LIES WITHIN THE  
GREATER VANCOUVER REGIONAL DISTRICT

*[Signature]*  
B.C.L.S.

**INTEGRATED TIES  
AND MONUMENTATION**

STRATA PLAN LMS 582

Scale 1 : 500 (All distances are in metres)

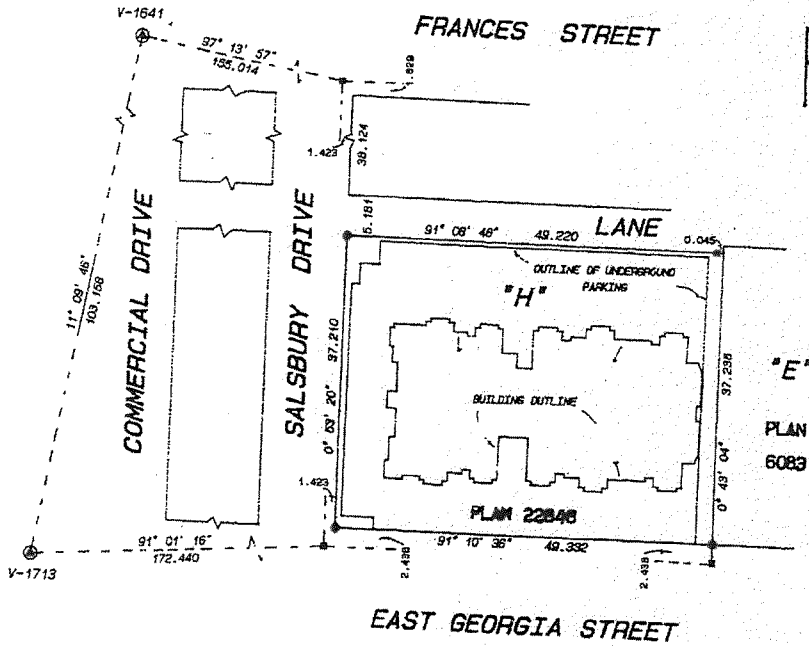
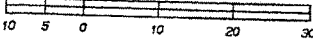

**LEGEND**

GRID BEARINGS ARE DERIVED FROM CONTROL MONUMENTS V-1713 AND V-1641

- ⊙ OCM DENOTES OLD CONTROL MONUMENT FOUND
- STANDARD IRON POST FOUND
- LEAD PLUS FOUND

THIS PLAN SHOWS GROUND-LEVEL MEASURED DISTANCES. PRIOR TO COMPUTATION OF U.T.M. COORDINATES, MULTIPLY BY COMBINED FACTOR 0.9995899737

FILE NUMBER: 89-2370.S2

*[Signature]*  
14 SEPTEMBER 1992 A.M.S.

**BUILDING LOCATION**

**STRATA PLAN LMS 582**

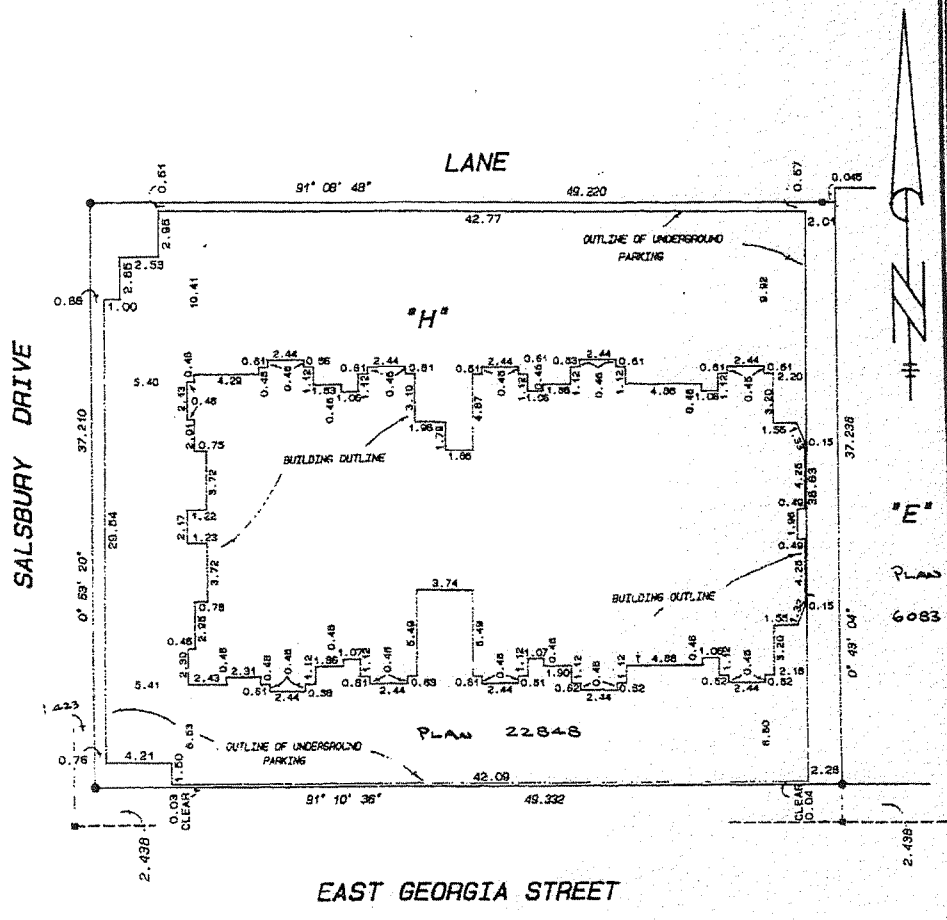
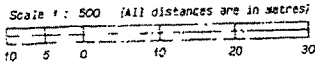

FILE NUMBER: 89-2370.53

*Robert Cutting*  
 14 SEPTEMBER 1992 B.C.L.S.

**CONDOMINIUM ACT**

**STRATA PLAN LMS 582**

LOT	SHEET	FORM 1	FORM 2	FORM 3
		SCHEDULE OF UNIT ENTITLEMENT	SCHEDULE OF INTEREST UPON DESTRUCTION	SCHEDULE OF VOTING RIGHTS
		UNIT ENTITLEMENT	INTEREST UPON DESTRUCTION	NUMBER OF VOTES
1	7	70	151	
2	7, 11	59	133	
3	7	57	121	
4	7	59	126	
5	7	66	139	
6	7, 12	67	137	
7	7, 12	59	123	
8	7, 12	57	114	
9	7, 11, 12	57	119	
10	7, 12	71	151	
11	8	70	149	
12	8, 11	63	132	
13	8	67	135	
14	8	59	124	
15	8	68	143	
16	8, 12	67	142	
17	8, 12	59	122	
18	8, 12	71	147	
19	8, 11, 12	59	119	
20	8, 12	71	149	
21	9	70	153	
22	9, 11	63	136	
23	9	67	139	
24	9	59	126	
25	9	66	147	
26	9, 12	67	145	
27	9, 12	59	125	
28	9, 12	71	149	
29	9, 11, 12	59	123	
30	9, 12	71	153	
31	10, 11	85	189	
32	10	67	146	
33	10	59	128	
34	10	66	150	
35	10, 12	67	150	
36	10, 12	59	127	
37	10, 12	71	151	
38	10, 11, 12	59	126	
39	10, 12	71	156	
AGGREGATE		2532	5394	

CONDOMINIUM ACT

STRATA PLAN LMS 582

ACCEPTED AS TO FORMS 1, 2 AND 3

THIS 14 DAY OF OCTOBER 1992. [Signature]  
SUPERINTENDENT OF REAL ESTATE

CERTIFICATE UNDER SECTION 8(1)

I, ROBERT G. FLYNN OF LADNER B.C., A BRITISH COLUMBIA LAND SURVEYOR,  
HEREBY CERTIFY THAT THE BUILDINGS SHOWN IN THIS STRATA PLAN HAVE NOT,  
AS OF THE 14th DAY OF SEPTEMBER 1992, BEEN PREVIOUSLY OCCUPIED.  
DATED AT VANCOUVER, B.C. THIS 14th DAY OF SEPTEMBER, 1992.

[Signature]  
B.C.L.S.

STATUTORY DECLARATION

I, THE UNDERSIGNED, SOLEMNLY DECLARE THAT  
(1) I, THE UNDERSIGNED, AM THE DULY AUTHORIZED  
AGENT OF THE OWNER - DEVELOPER  
(2) THE STRATA PLAN IS ENTIRELY FOR RESIDENTIAL USE

DECLARED BEFORE ME AT VANCOUVER  
IN THE PROVINCE OF BRITISH COLUMBIA,  
THIS 15 DAY OF OCT, 1992.

I MAKE THIS SOLEMN DECLARATION CONSCIENTIOUSLY  
BELIEVING IT TO BE TRUE AND KNOWING THAT  
IT IS OF THE SAME FORCE AND EFFECT  
AS IF MADE UNDER OATH.

[Signature]  
AGENT FOR OWNER - DEVELOPER

[Signature]  
A COMMISSIONER FOR THE TAKING  
OF AFFIDAVITS IN AND FOR THE  
PROVINCE OF BRITISH COLUMBIA

OWNERS:

KINOH USUKI DEVELOPMENTS LTD.  
(INCORPORATION NO. 374976)

[Signature]  
AUTHORIZED SIGNATORY

[Signature]  
AUTHORIZED SIGNATORY

[Signature]  
WITNESS AS TO BOTH SIGNATURES

476-1367 W. BAYVIEW UNIT  
ADDRESS OF WITNESS

Lawyer  
OCCUPATION OF WITNESS

MORTGAGEE:

CANADIAN IMPERIAL BANK OF COMMERCE

[Signature] [Signature] Brook Elliott  
AUTHORIZED SIGNATORY

[Signature] [Signature] Elizabeth R Dixon  
AUTHORIZED SIGNATORY

[Signature]  
WITNESS AS TO BOTH SIGNATURES

Elizabeth A. Winogate  
ADDRESS OF WITNESS  
16 Floor, 1000 Burrard St  
Vancouver, B.C. V6C 3A6

Banker  
OCCUPATION OF WITNESS



FLOOR PLANS

FIRST FLOOR

SHEET 7 OF 14 SHEETS

STRATA PLAN LMS 582

Scale 1 : 200 (All distances are in metres)

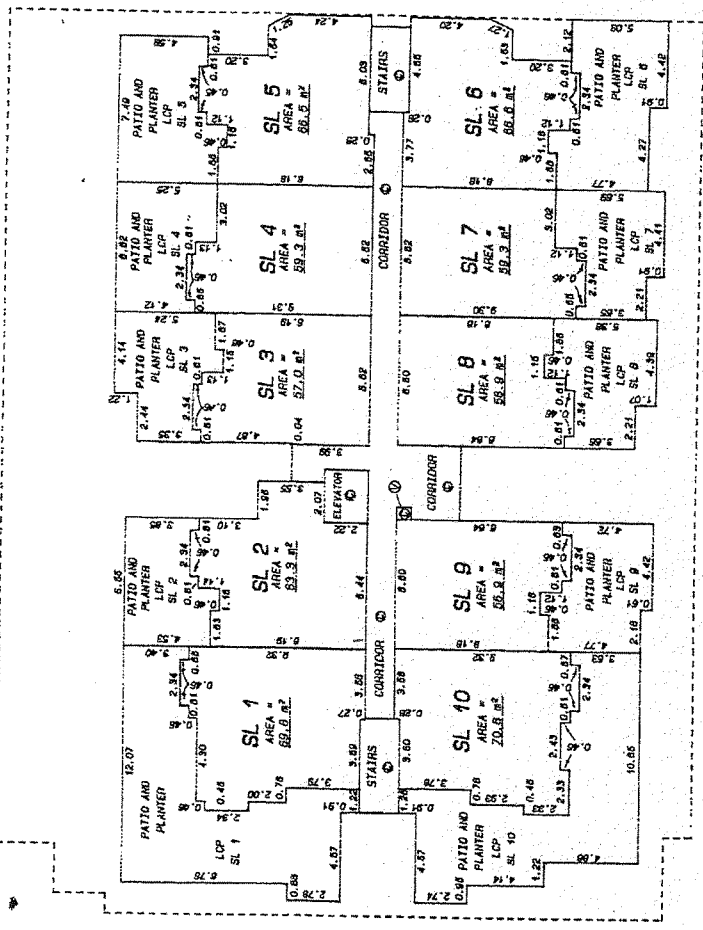
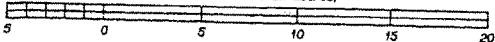

FILE: 89 - 2370.57

*Robert C. ...*  
SEPTEMBER 14, 1992 C.L.S.

FLOOR PLANS

SECOND FLOOR

SHEET 8 OF 14 SHEETS

STRATA PLAN LMS 582

Scale 1 : 200 (All distances are in metres)

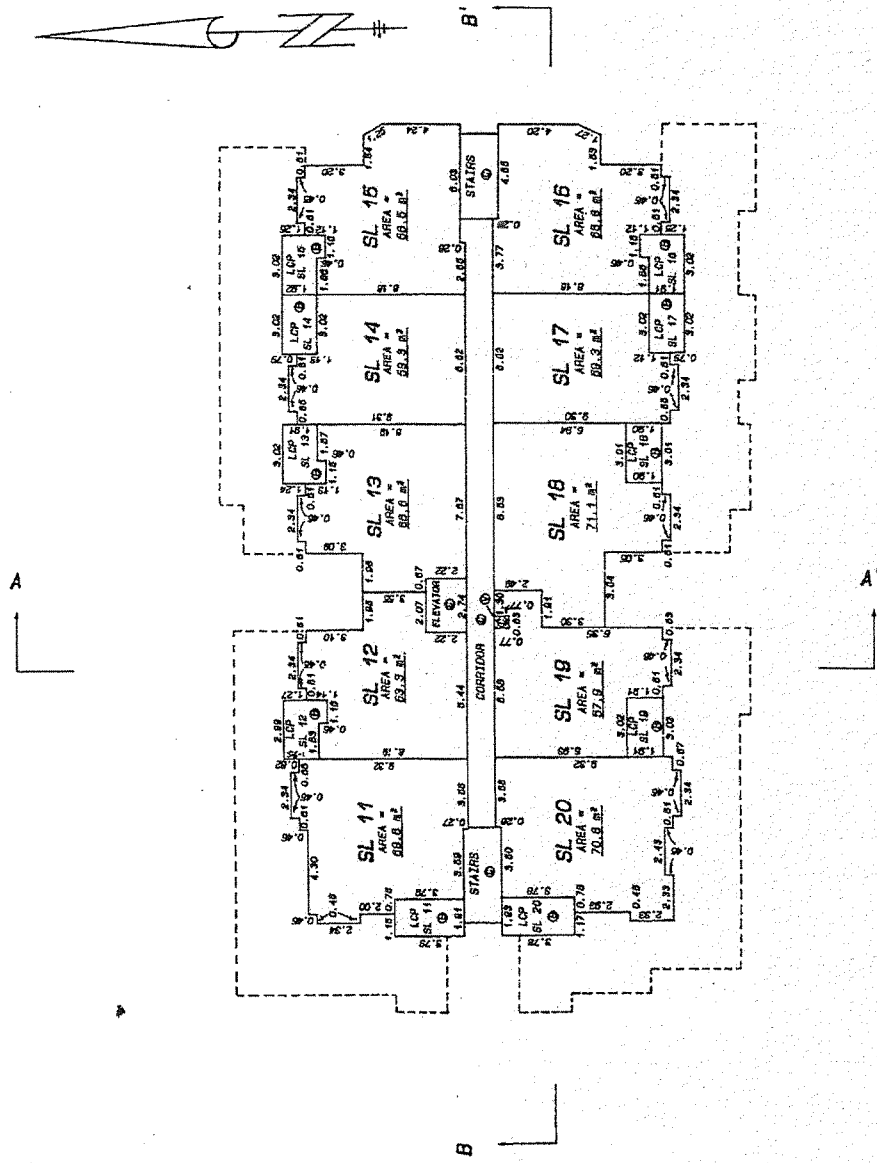
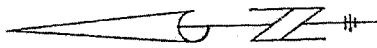

FILE: 89 - 2370.59

*Robert C. Little*  
SEPTMBER 14, 1990 P.C.L.S.

**FLOOR PLANS**

**THIRD FLOOR**

SHEET 9 OF 14 SHEETS

**STRATA PLAN LMS 582**

Scale 1 : 200 (All distances are in metres)

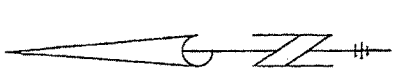
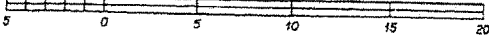

A

B

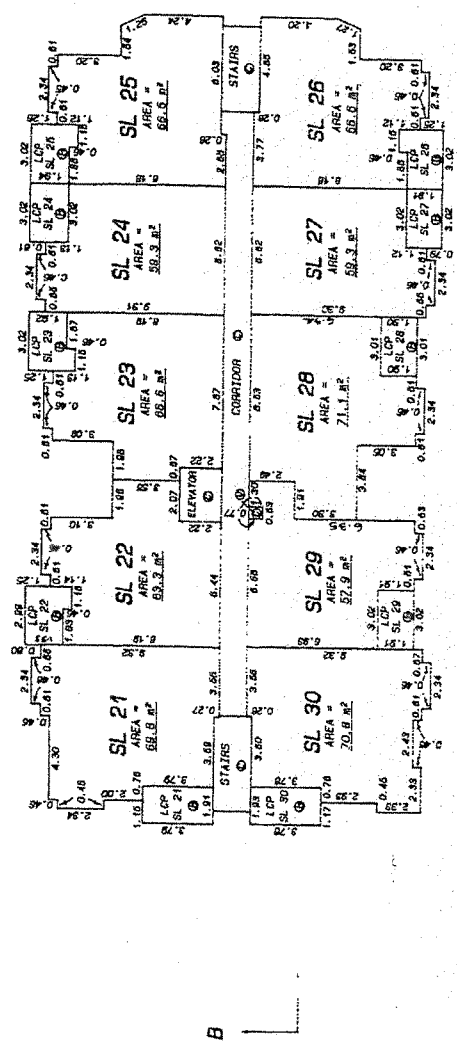

FILE: 89 - 2370.S9

*Robert C. [Signature]*  
SEPTEMBER 14, 1992 B.C.L.S.

FLOOR PLANS

FOURTH FLOOR

SHEET 10 OF 14 SHEETS

STRATA PLAN LMS 582

Scale 1 : 200 (All distances are in metres)

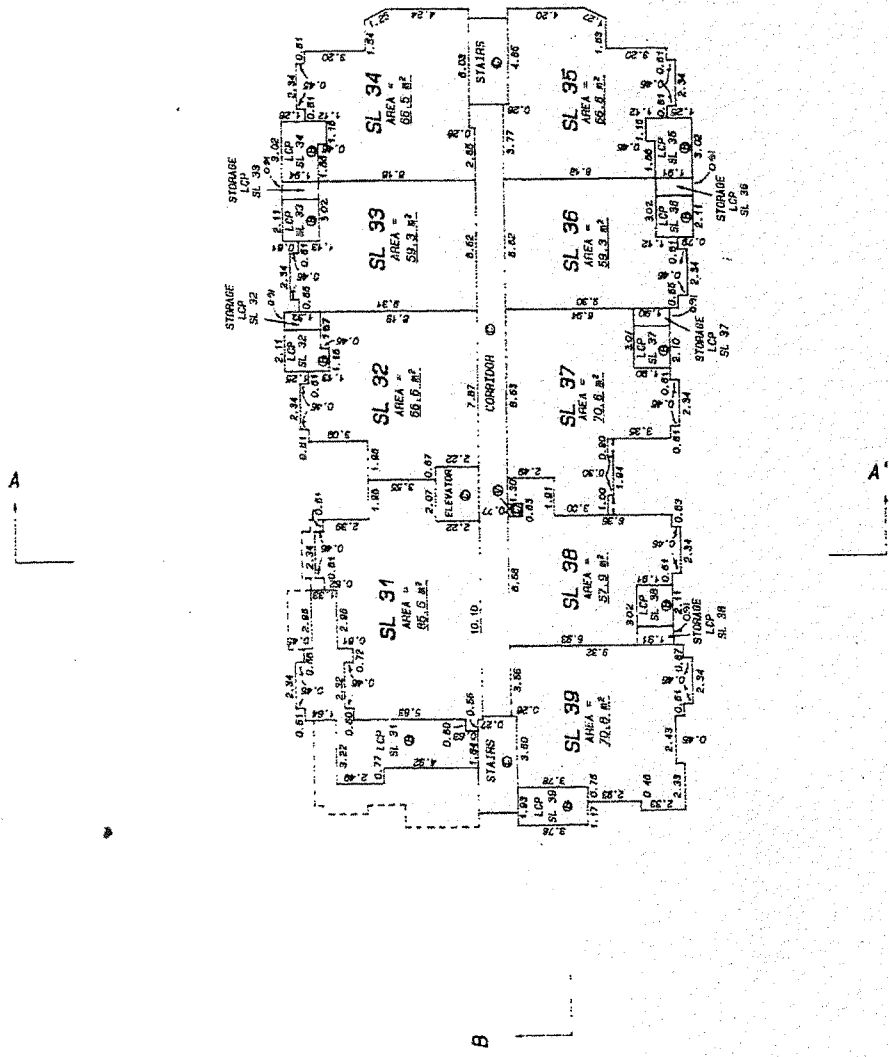
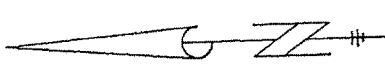
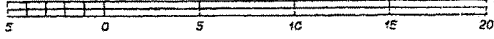

FILE: 89 - 2370.510

*Robert C. ...*  
SEPTEMBER 14, 1989 P.C.L.S.

**CROSS SECTIONS**

**STRATA PLAN LMS**

582

Scale 1 : 200 (All distances are in metres)

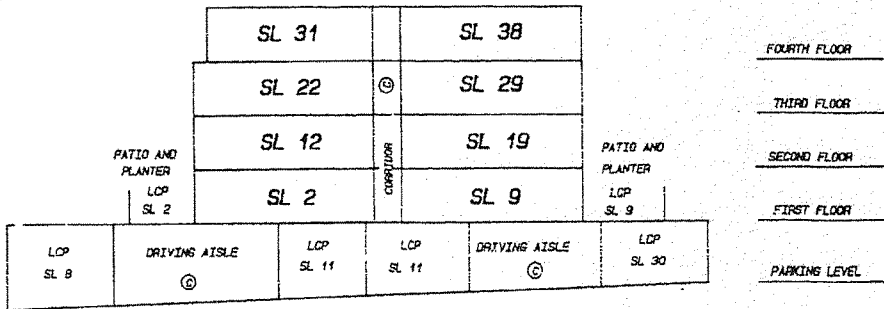
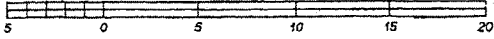

**SECTION A - A'**

FILE: 89 - 2370.511

*Robert G. [Signature]*  
 SEPTEMBER 14, 1988 B.C.L.S.

**CROSS SECTIONS**

SHEET 12 OF 14 SHEETS

**STRATA PLAN LMS 582**

Scale 1 : 200 (All distances are in metres)

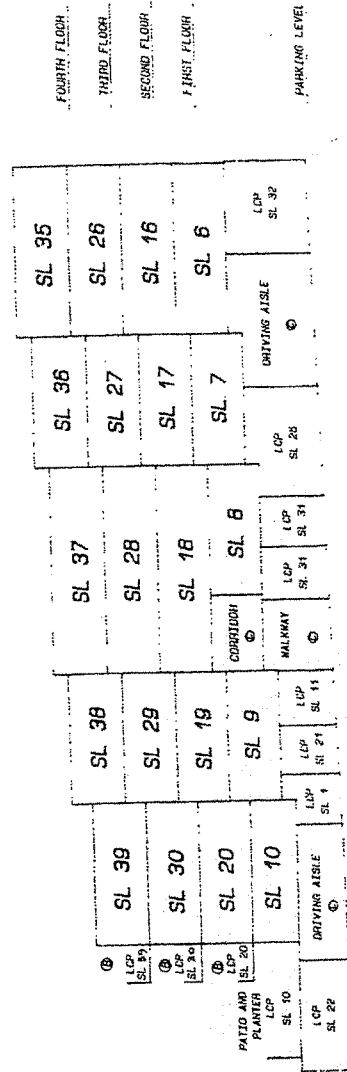
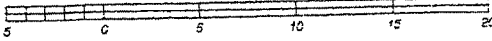

**SECTION B - B'**

FILE: 89 - 2370.S12

SEPTEMBER 14, 1992

B.C.S.

*Robert C. S. [Signature]*



