

# STRATA PLAN OF PART LOT 1, Bk 10, DL 200A, Gp 1, NWD, PLAN EPP28058, EXCEPT AIR SPACE PARCELS A AND B, AIR SPACE PLAN EPP44063.

# STRATA PLAN EPS2328

CITY OF VANCOUVER  
BCGS 92G.025  
CIVIC ADDRESS: 1783 MANITOBA ST, VANCOUVER, BC.

AIR SPACE PARCEL  
DIMENSIONS AT GROUND LEVEL  
SEE SHEET 4

AIR SPACE PARCEL  
AND BUILDING DETAILS  
SEE SHEETS 2 TO 8

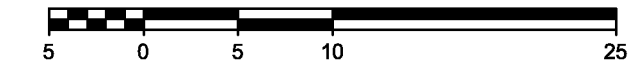

ALL DISTANCES ARE IN METRES AND DECIMALS THEREOF.

THE INTENDED PLOT SIZE OF THIS PLAN IS  
432mm IN WIDTH BY 280mm IN HEIGHT (B SIZE)  
WHEN PLOTTED AT A SCALE OF 1:400.

ALL ANGLES ARE 45° OR 90° AND MULTIPLES THEREOF,  
UNLESS OTHERWISE NOTED.

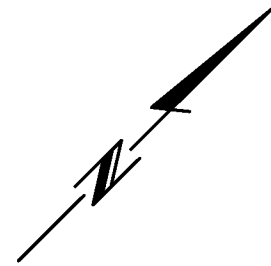

### LEGEND

- ⊙ - DENOTES CONTROL MONUMENT
- - DENOTES LEAD PLUG FOUND
- Wt - DENOTES WITNESS
- US - DENOTES UNSUITABLE FOR POSTING
- SL - DENOTES STRATA LOT
- PT - DENOTES PART
- A - DENOTES AREA
- LCP - DENOTES LIMITED COMMON PROPERTY
- BDY - DENOTES BOUNDARY
- BLD - DENOTES BUILDING
- NTS - DENOTES NOT TO SCALE
- OTB - DENOTES OPEN TO BELOW
- PFB - DENOTES PERIMETER OF FLOOR BELOW
- ⊕ - DENOTES COMMON PROPERTY
- ⊖ - DENOTES ELECTRICAL COMMON PROPERTY
- Ⓜ - DENOTES MECHANICAL COMMON PROPERTY

**BENNETT LAND SURVEYING LTD.**  
B.C. LAND SURVEYORS  
#201 - 275 FELL AVENUE  
NORTH VANCOUVER, B.C.  
V7P 3R5  
PH. 604-980-4868  
FX. 604-980-5856  
www.bennettsurveys.com  
FB636 P16 (TH/TH)

### NOTES

GRID BEARINGS ARE DERIVED FROM PLAN BCP50719.  
THIS PLAN SHOWS HORIZONTAL GROUND-LEVEL DISTANCES  
EXCEPT WHERE OTHERWISE NOTED. TO COMPUTE GRID  
DISTANCES, MULTIPLY GROUND-LEVEL DISTANCES BY  
COMBINED FACTOR 0.9996030, WHICH HAS BEEN DERIVED  
FROM GEODETIC CONTROL MONUMENTS 191 AND V-2178.

THIS PLAN SHOWS ONE OR MORE WITNESS POSTS WHICH  
ARE NOT SET ON THE TRUE CORNERS.

NEW POSTS SHOWN ON THIS PLAN SET FROM THE  
REFERENCE NOTES OF J. NEIL BENNETT, BCLS.

THIS PLAN LIES WITHIN THE  
GREATER VANCOUVER REGIONAL DISTRICT

THE BUILDING SHOWN HEREON IS WITHIN THE  
EXTERNAL BOUNDARIES OF THE LAND THAT IS  
THE SUBJECT OF THE STRATA PLAN.

THE BUILDING INCLUDED IN THIS STRATA PLAN  
HAS NOT BEEN PREVIOUSLY OCCUPIED.

THE FIELD SURVEY REPRESENTED BY THIS PLAN  
WAS COMPLETED ON THE 14TH DAY OF OCTOBER, 2014.

J. NEIL BENNETT, BCLS #527

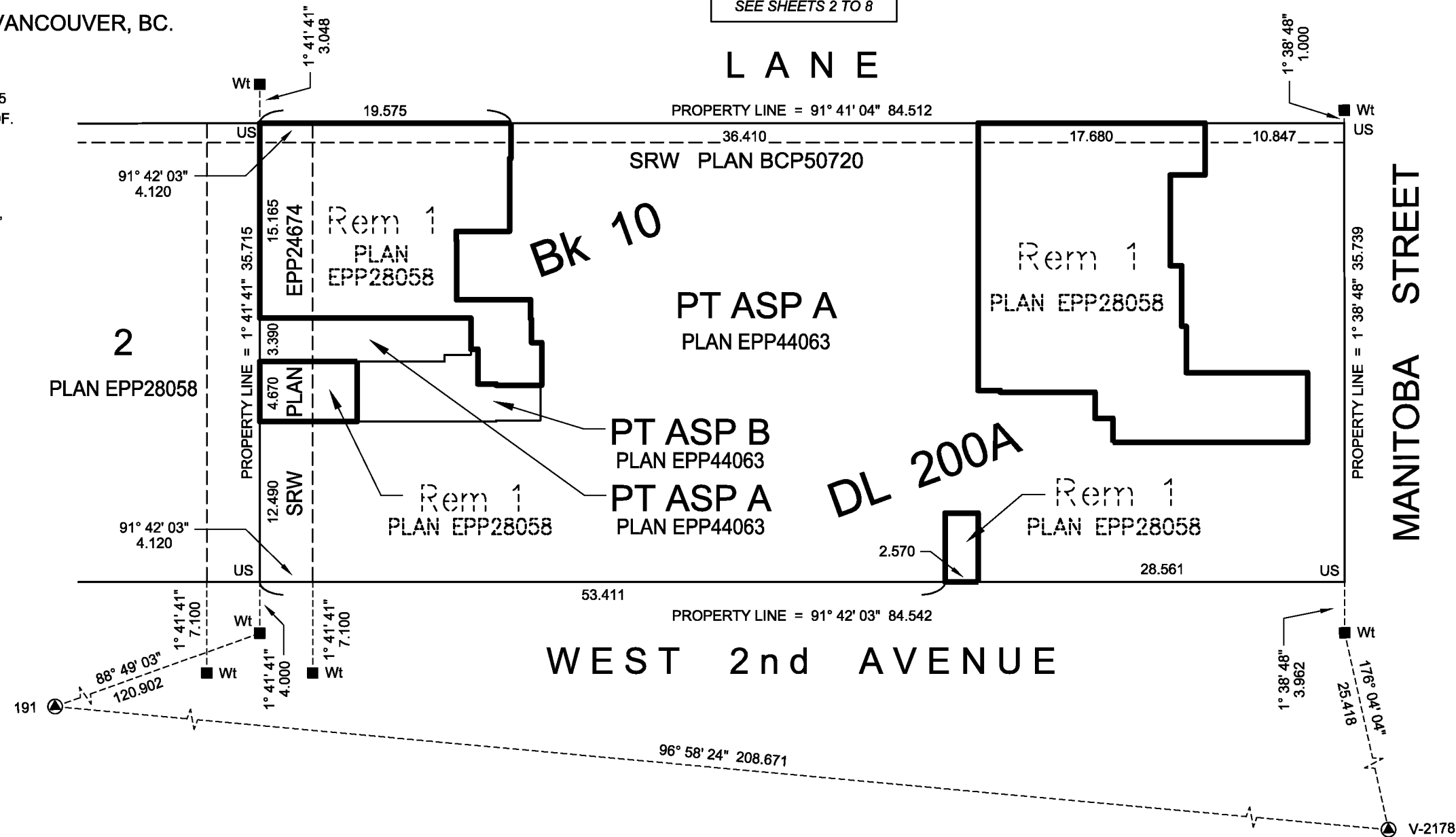

# AIR SPACE PARCEL AND BUILDING DETAILS

# STRATA PLAN EPS2328

## BUILDING OUTLINE

BELOW ELEVATION -0.44 m  
( LEVELS P3, P2, AND PART P1B )



ALL DISTANCES ARE IN METRES AND DECIMALS THEREOF.

THE INTENDED PLOT SIZE OF THIS PLAN IS  
432mm IN WIDTH BY 280mm IN HEIGHT (B SIZE)  
WHEN PLOTTED AT A SCALE OF 1:300.

ALL ANGLES ARE 45° OR 90° AND MULTIPLES THEREOF,  
UNLESS OTHERWISE NOTED.

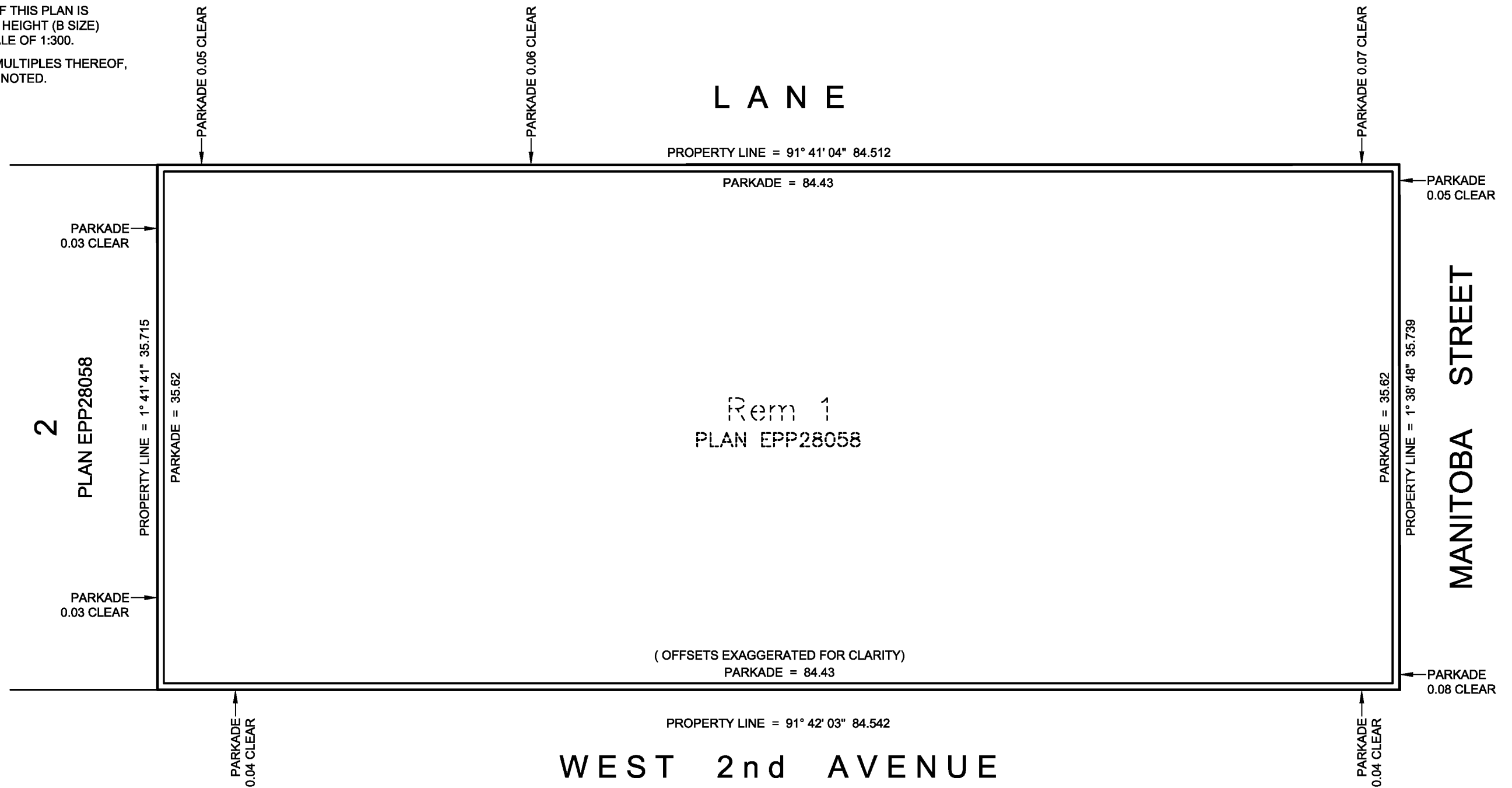
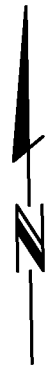

J. NEIL BENNETT, BCLS #527  
DECEMBER 1, 2014





# AIR SPACE PARCEL AND BUILDING DETAILS

## BUILDING OUTLINE AND PART ASP A ( LEVEL C )

ELEVATIONS 9.60 m TO 17.55 m

( LEVELS 2 TO 4; DEVELOPER'S LEVELS 2 TO 5 )



ALL DISTANCES ARE IN METRES AND DECIMALS THEREOF.

THE INTENDED PLOT SIZE OF THIS PLAN IS 432mm IN WIDTH BY 280mm IN HEIGHT (B SIZE) WHEN PLOTTED AT A SCALE OF 1:300.

ALL ANGLES ARE 45° OR 90° AND MULTIPLES THEREOF, UNLESS OTHERWISE NOTED.

# STRATA PLAN EPS2328

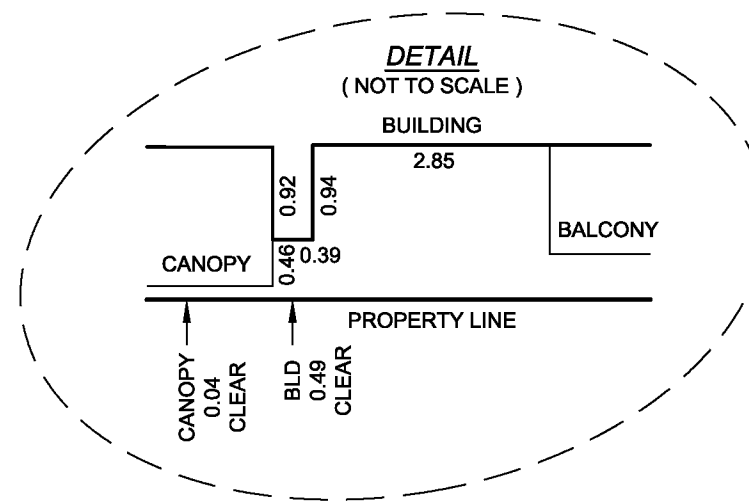

### LANE

ASP = PROPERTY LINE = 91° 41' 04" 84.512

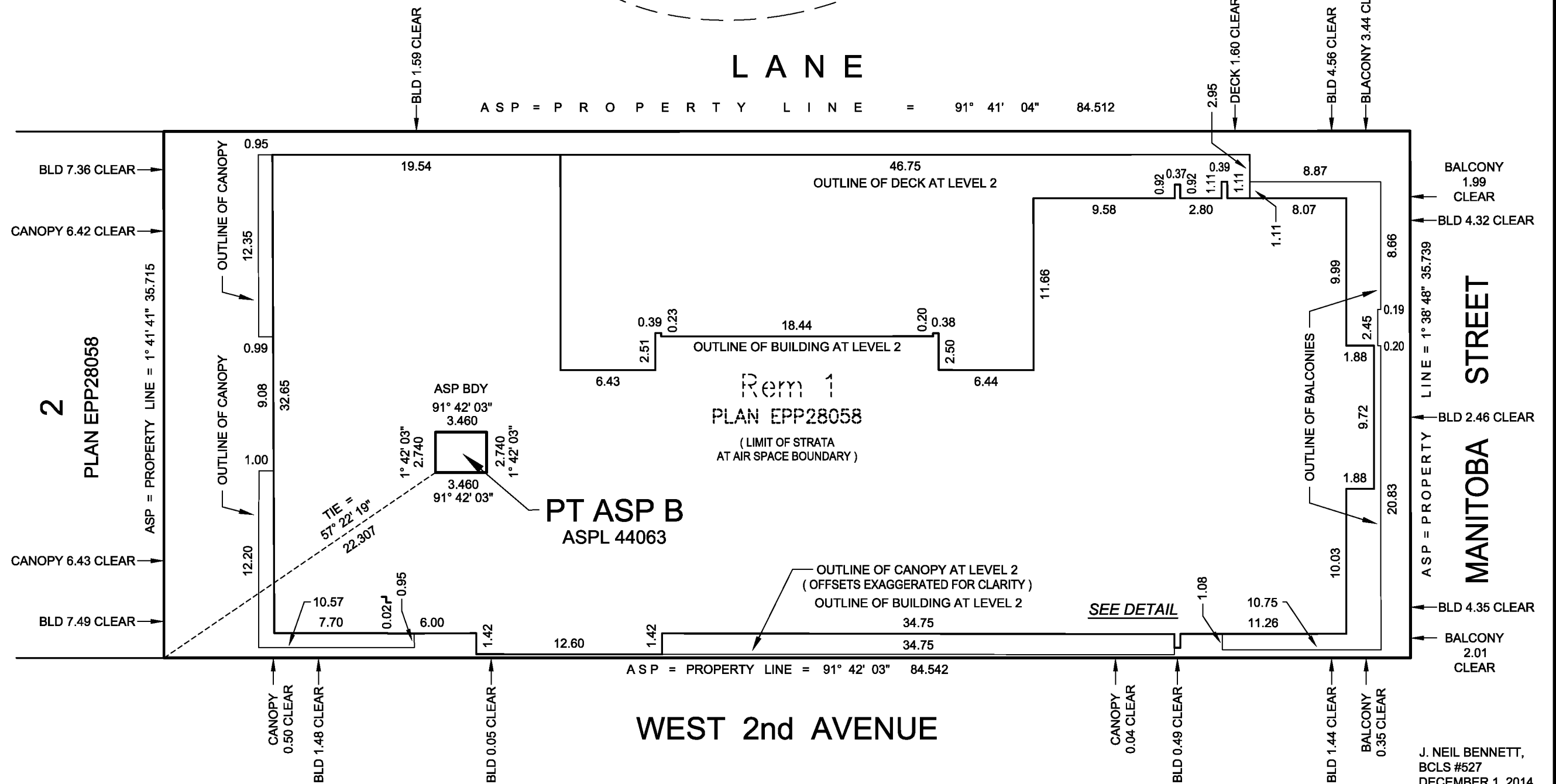

J. NEIL BENNETT,  
BCLS #527  
DECEMBER 1, 2014



**AIR SPACE PARCEL AND BUILDING DETAILS**  
**BUILDING OUTLINE AND PART ASP A ( LEVEL D )**  
 ELEVATIONS 20.60 m TO 24.85 m  
 ( LEVEL 6; DEVELOPER'S LEVEL 7 )

**STRATA PLAN EPS2328**



THE INTENDED PLOT SIZE OF THIS PLAN IS  
 432mm IN WIDTH BY 280mm IN HEIGHT (B SIZE)  
 WHEN PLOTTED AT A SCALE OF 1:300.

ALL ANGLES ARE 45° OR 90° AND MULTIPLES THEREOF,  
 UNLESS OTHERWISE NOTED.

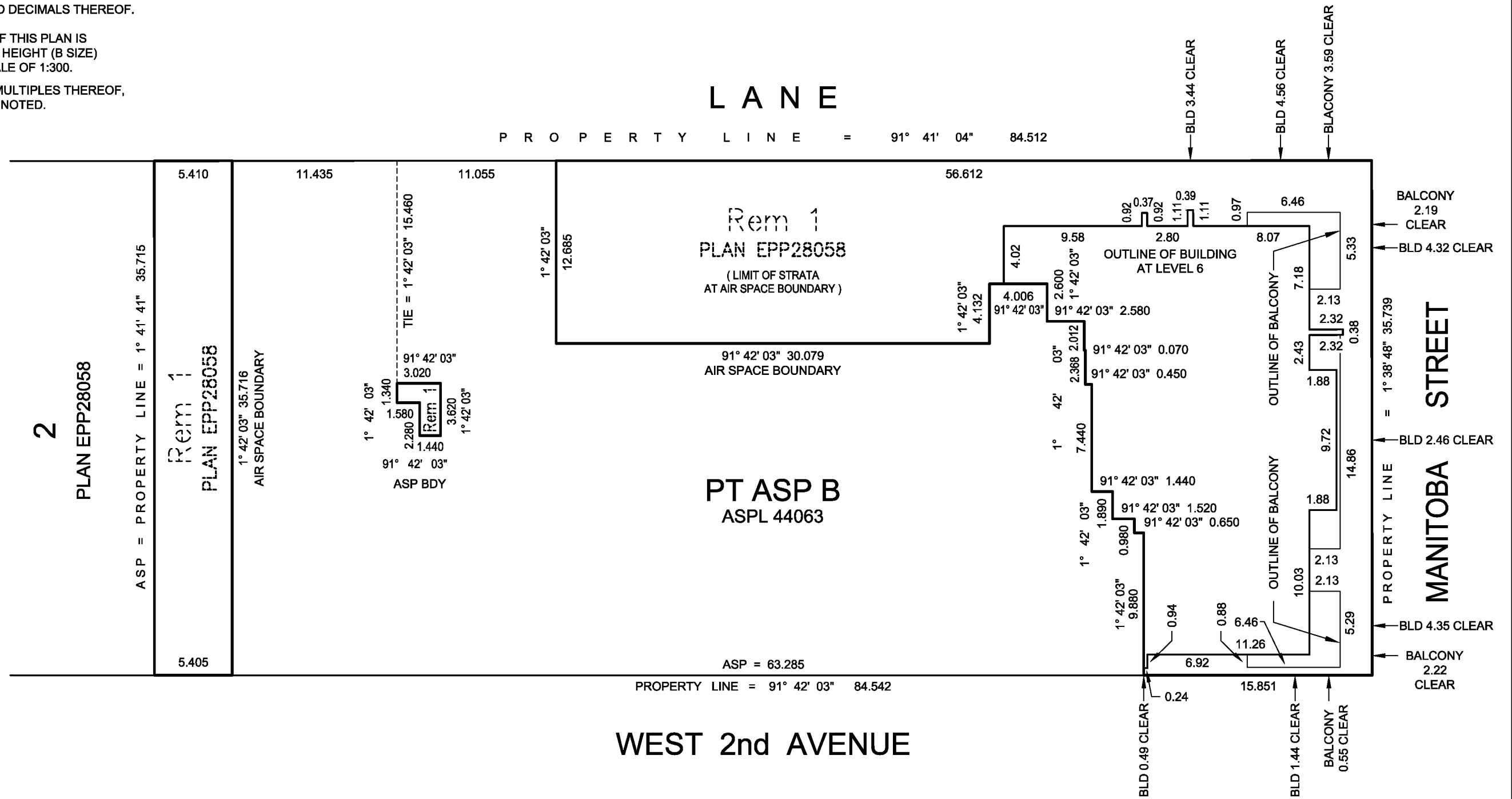
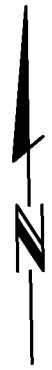

J. NEIL BENNETT, BCLS #527  
 DECEMBER 1, 2014

# AIR SPACE PARCEL AND BUILDING DETAILS

# STRATA PLAN EPS2328

## BUILDING OUTLINE

ABOVE ELEVATION 24.85 m

( LEVELS 7 [ DEVELOPER'S LEVEL 8 ] TO ROOF )



ALL DISTANCES ARE IN METRES AND DECIMALS THEREOF.

THE INTENDED PLOT SIZE OF THIS PLAN IS  
432mm IN WIDTH BY 280mm IN HEIGHT (B SIZE)  
WHEN PLOTTED AT A SCALE OF 1:300.

ALL ANGLES ARE 45° OR 90° AND MULTIPLES THEREOF,  
UNLESS OTHERWISE NOTED.

# LANE

PROPERTY LINE = 91° 41' 04" 84.512

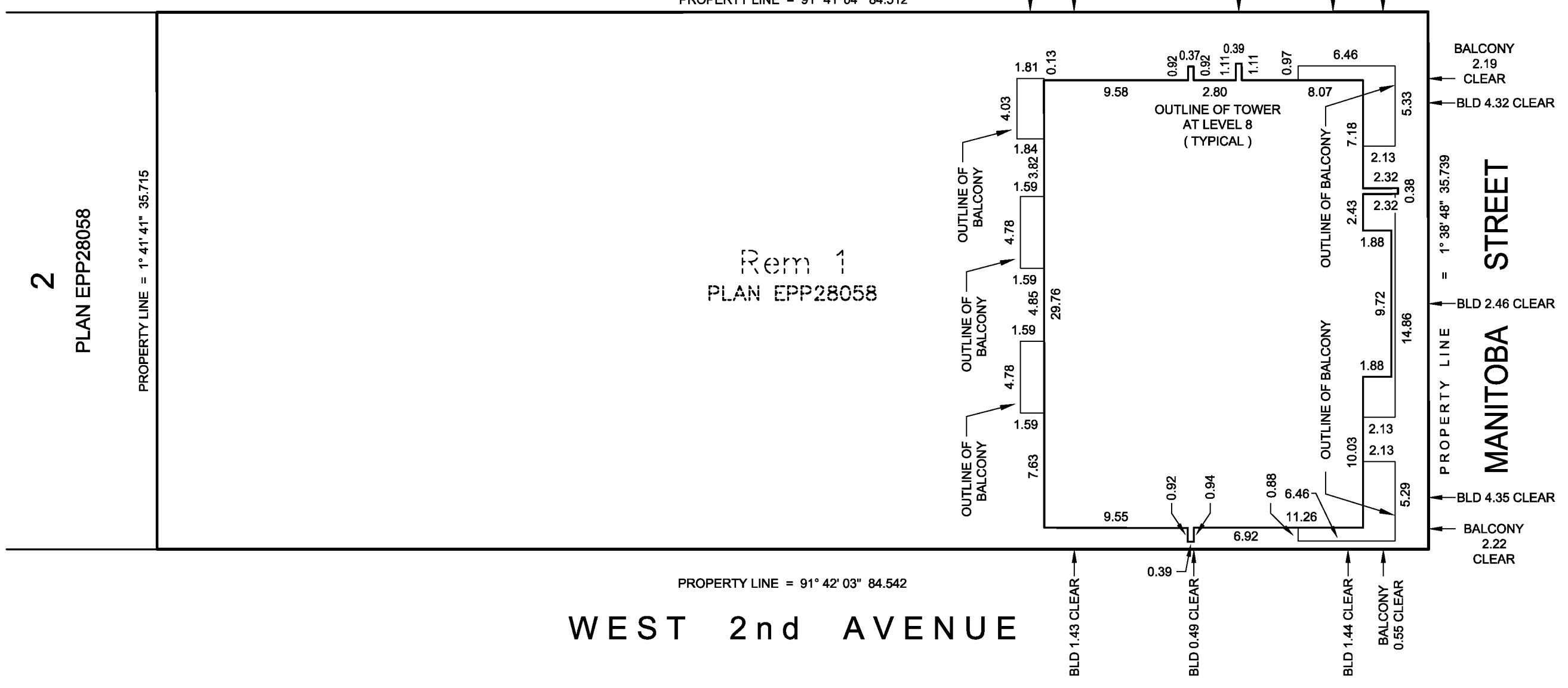
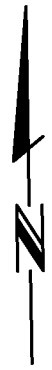

J. NEIL BENNETT, BCLS #527  
DECEMBER 1, 2014

# PARKING LEVEL P3 FLOOR PLAN ( WESTERN PORTION )

# STRATA PLAN EPS2328



ALL DISTANCES ARE IN METRES AND DECIMALS THEREOF.

THE INTENDED PLOT SIZE OF THIS PLAN IS  
432mm IN WIDTH BY 280mm IN HEIGHT (B SIZE)  
WHEN PLOTTED AT A SCALE OF 1:200.

ALL ANGLES ARE 45° OR 90° AND MULTIPLES THEREOF,  
UNLESS OTHERWISE NOTED.

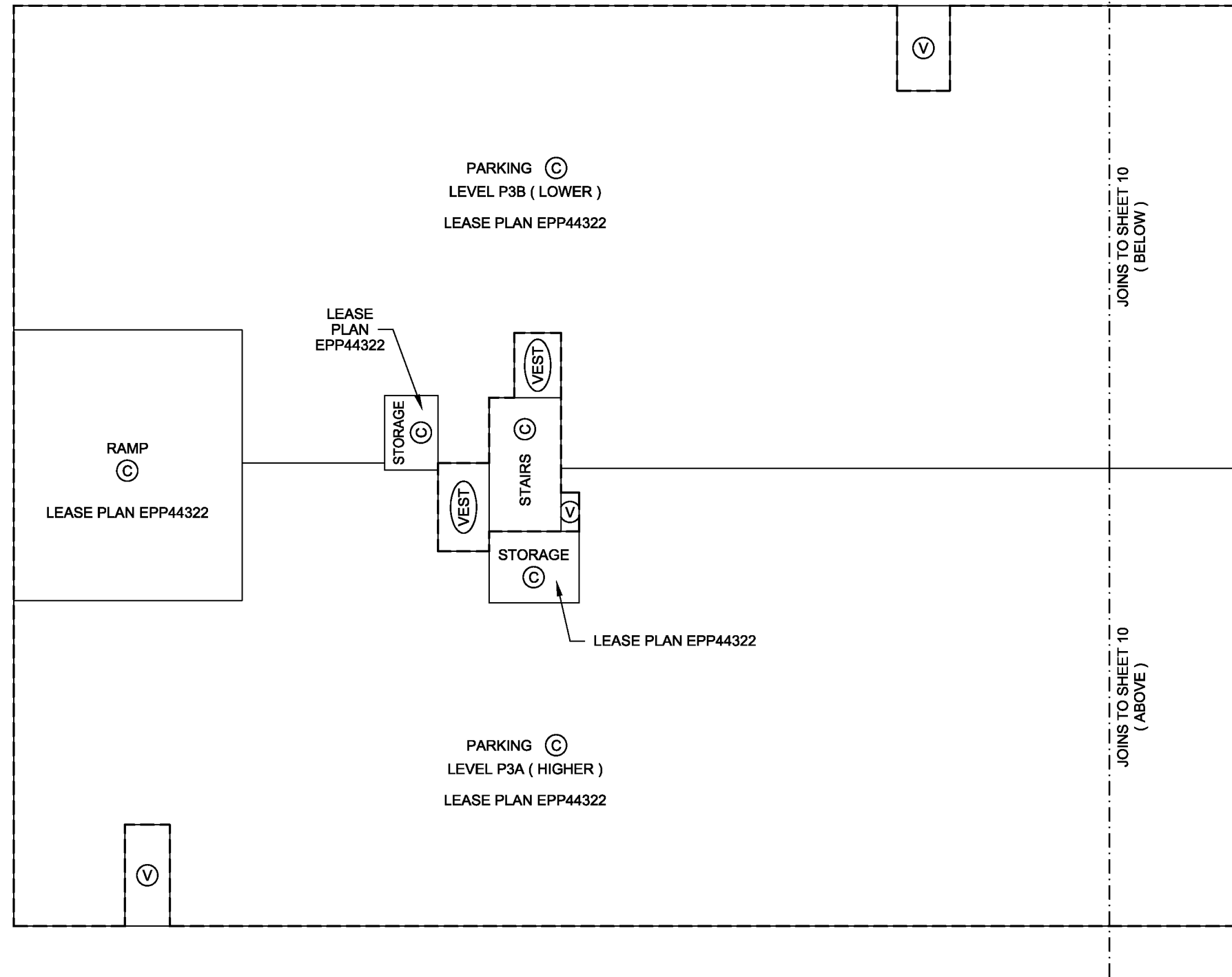
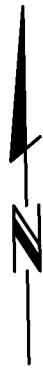

J. NEIL BENNETT, BCLS #527  
DECEMBER 1, 2014

# PARKING LEVEL P3 FLOOR PLAN ( EASTERN PORTION )

# STRATA PLAN EPS2328



ALL DISTANCES ARE IN METRES AND DECIMALS THEREOF.

THE INTENDED PLOT SIZE OF THIS PLAN IS  
432mm IN WIDTH BY 280mm IN HEIGHT (B SIZE)  
WHEN PLOTTED AT A SCALE OF 1:200.

ALL ANGLES ARE 45° OR 90° AND MULTIPLES THEREOF,  
UNLESS OTHERWISE NOTED.

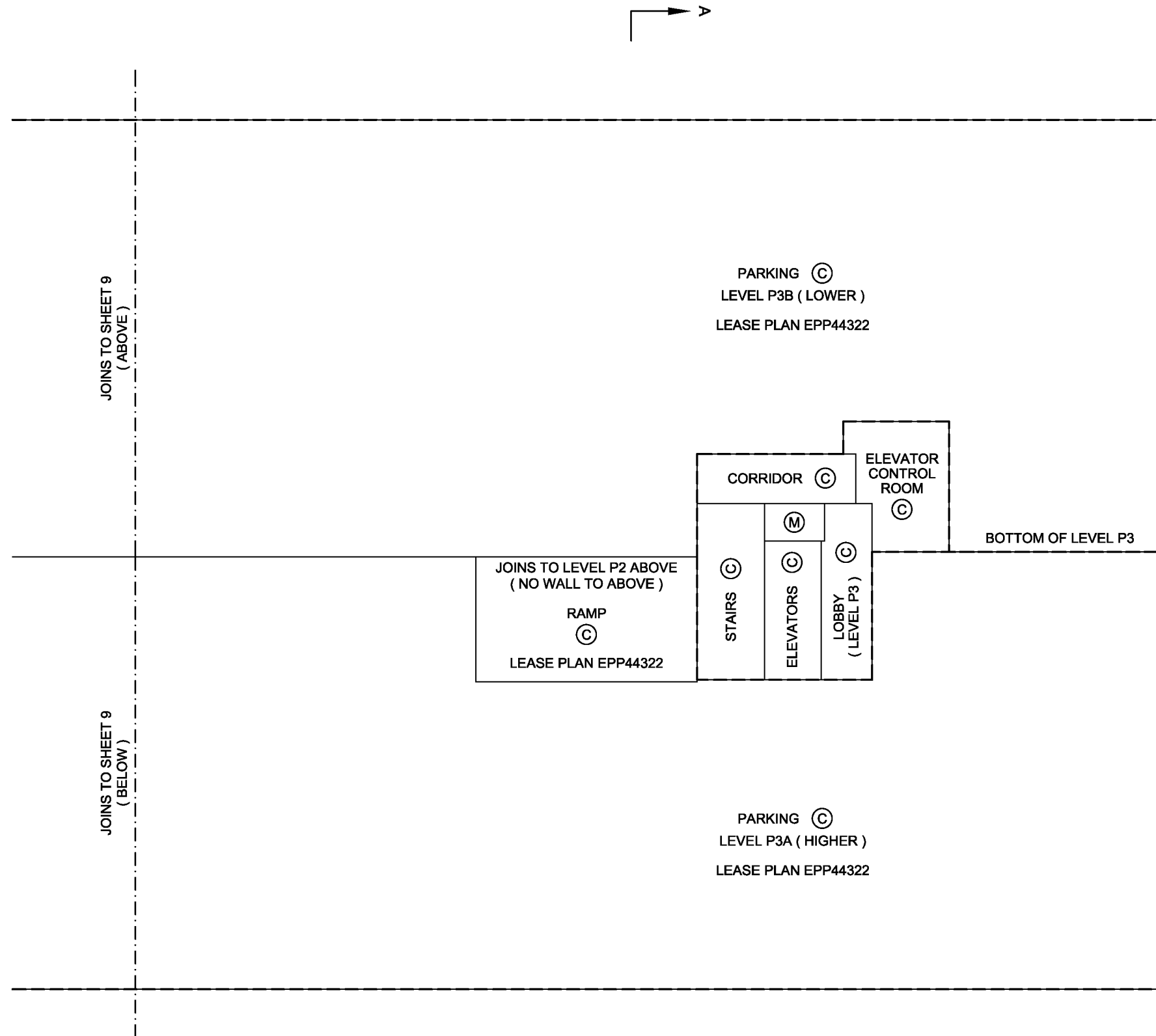
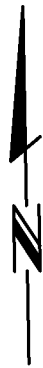

J. NEIL BENNETT, BCLS #527  
DECEMBER 1, 2014

# PARKING LEVEL P2 FLOOR PLAN ( WESTERN PORTION )

# STRATA PLAN EPS2328



ALL DISTANCES ARE IN METRES AND DECIMALS THEREOF.

THE INTENDED PLOT SIZE OF THIS PLAN IS  
432mm IN WIDTH BY 280mm IN HEIGHT (B SIZE)  
WHEN PLOTTED AT A SCALE OF 1:200.

ALL ANGLES ARE 45° OR 90° AND MULTIPLES THEREOF,  
UNLESS OTHERWISE NOTED.

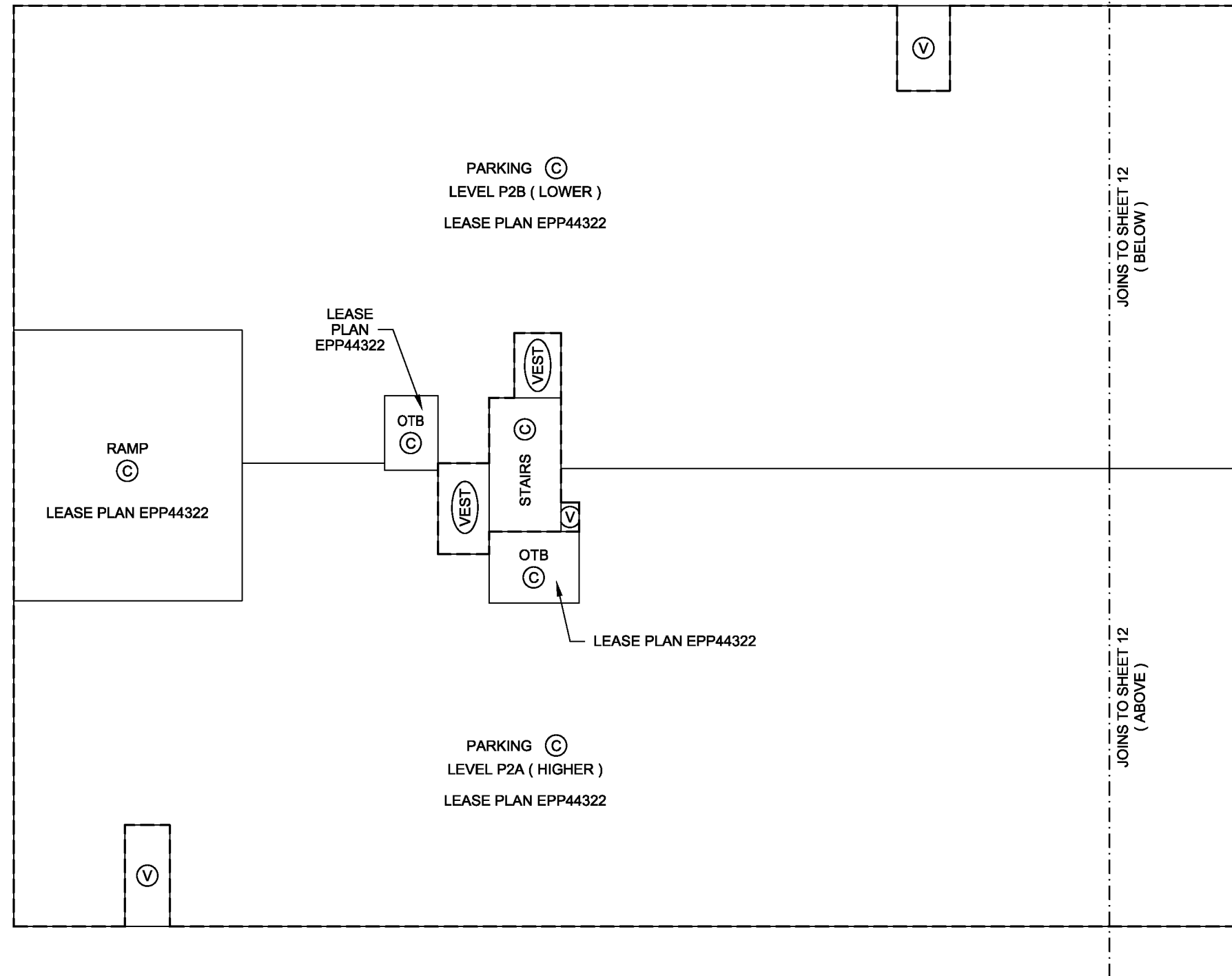
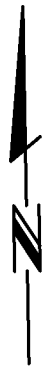

J. NEIL BENNETT, BCLS #527  
DECEMBER 1, 2014

# PARKING LEVEL P2 FLOOR PLAN ( EASTERN PORTION )

# STRATA PLAN EPS2328



ALL DISTANCES ARE IN METRES AND DECIMALS THEREOF.

THE INTENDED PLOT SIZE OF THIS PLAN IS  
432mm IN WIDTH BY 280mm IN HEIGHT (B SIZE)  
WHEN PLOTTED AT A SCALE OF 1:200.

ALL ANGLES ARE 45° OR 90° AND MULTIPLES THEREOF,  
UNLESS OTHERWISE NOTED.

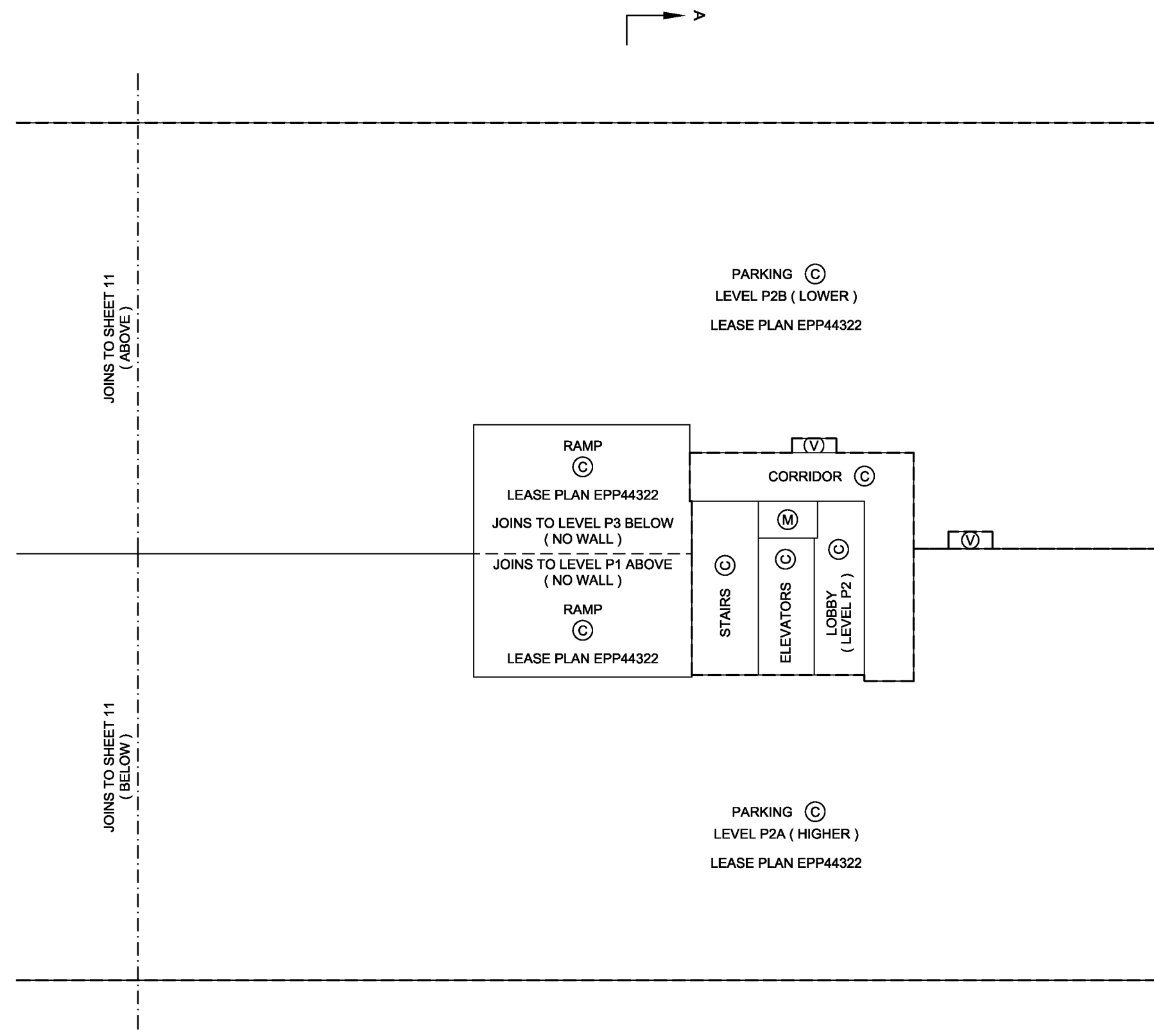
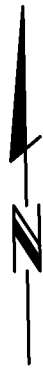

J. NEIL BENNETT, BCLS #527  
DECEMBER 1, 2014

# PARKING LEVEL P1B ( LOWER ) FLOOR PLAN ( WESTERN PORTION )

# STRATA PLAN EPS2328



ALL DISTANCES ARE IN METRES AND DECIMALS THEREOF.

THE INTENDED PLOT SIZE OF THIS PLAN IS  
432mm IN WIDTH BY 280mm IN HEIGHT (B SIZE)  
WHEN PLOTTED AT A SCALE OF 1:200.

ALL ANGLES ARE 45° OR 90° AND MULTIPLES THEREOF,  
UNLESS OTHERWISE NOTED.

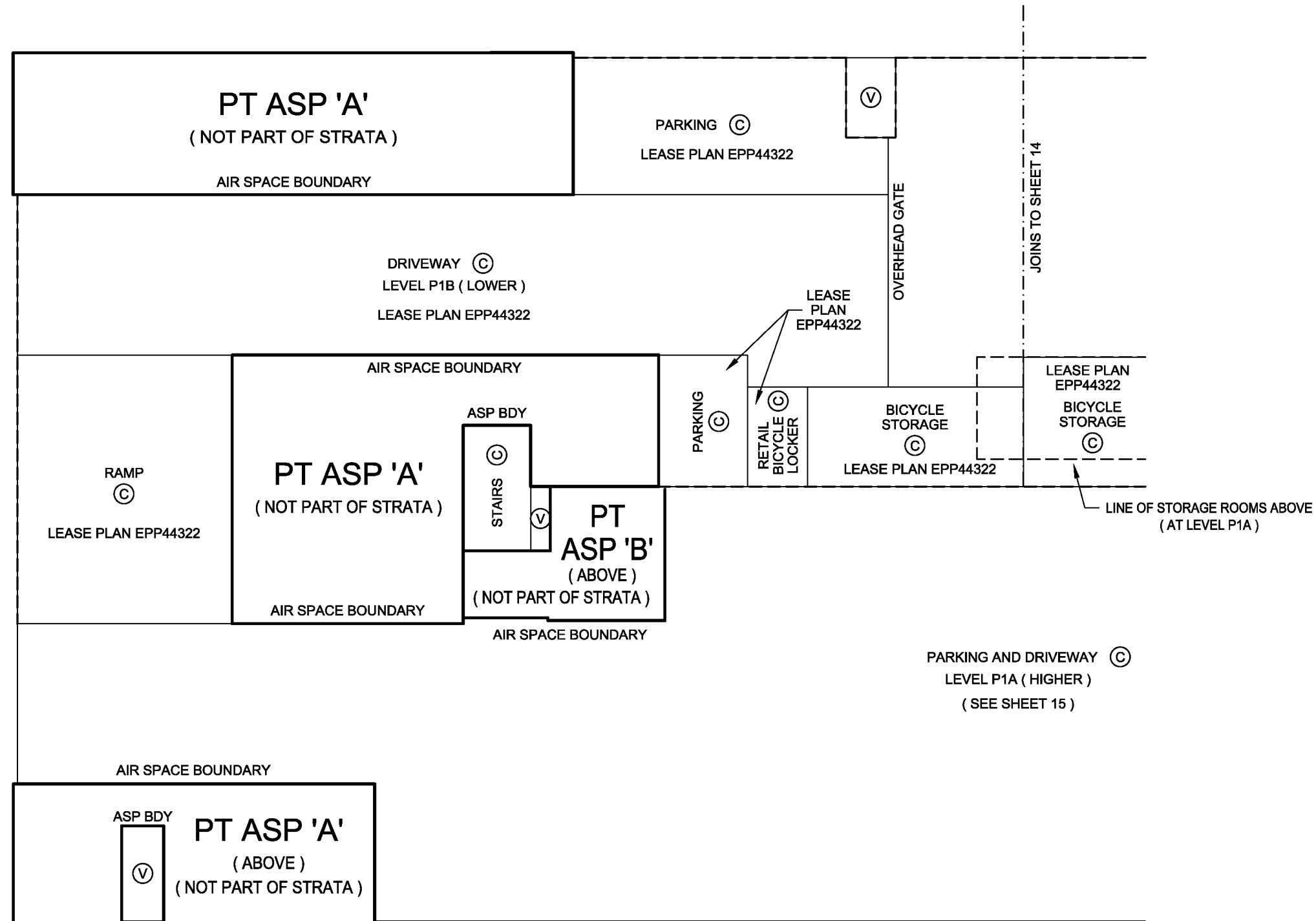

J. NEIL BENNETT, BCLS #527  
DECEMBER 1, 2014

# PARKING LEVEL P1B ( LOWER ) FLOOR PLAN ( EASTERN PORTION )

# STRATA PLAN EPS2328



ALL DISTANCES ARE IN METRES AND DECIMALS THEREOF.

THE INTENDED PLOT SIZE OF THIS PLAN IS  
432mm IN WIDTH BY 280mm IN HEIGHT (B SIZE)  
WHEN PLOTTED AT A SCALE OF 1:200.

ALL ANGLES ARE 45° OR 90° AND MULTIPLES THEREOF,  
UNLESS OTHERWISE NOTED.

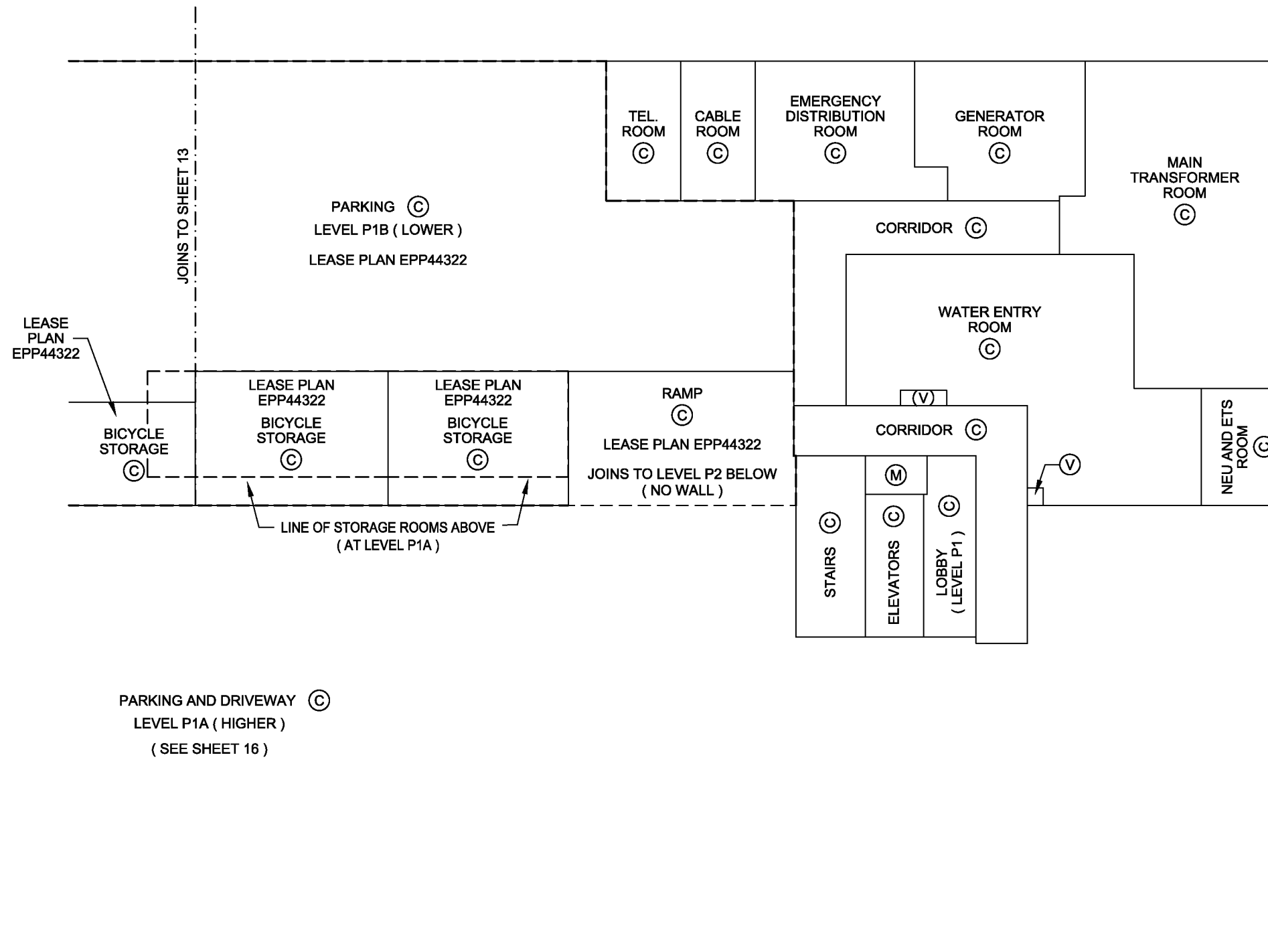

**PARKING AND DRIVEWAY (C)  
LEVEL P1A ( HIGHER )  
( SEE SHEET 16 )**



J. NEIL BENNETT, BCLS #527  
DECEMBER 1, 2014

# PARKING LEVEL P1A ( HIGHER ) FLOOR PLAN ( WESTERN PORTION )

# STRATA PLAN EPS2328



ALL DISTANCES ARE IN METRES AND DECIMALS THEREOF.

THE INTENDED PLOT SIZE OF THIS PLAN IS  
432mm IN WIDTH BY 280mm IN HEIGHT (B SIZE)  
WHEN PLOTTED AT A SCALE OF 1:200.

ALL ANGLES ARE 45° OR 90° AND MULTIPLES THEREOF,  
UNLESS OTHERWISE NOTED.

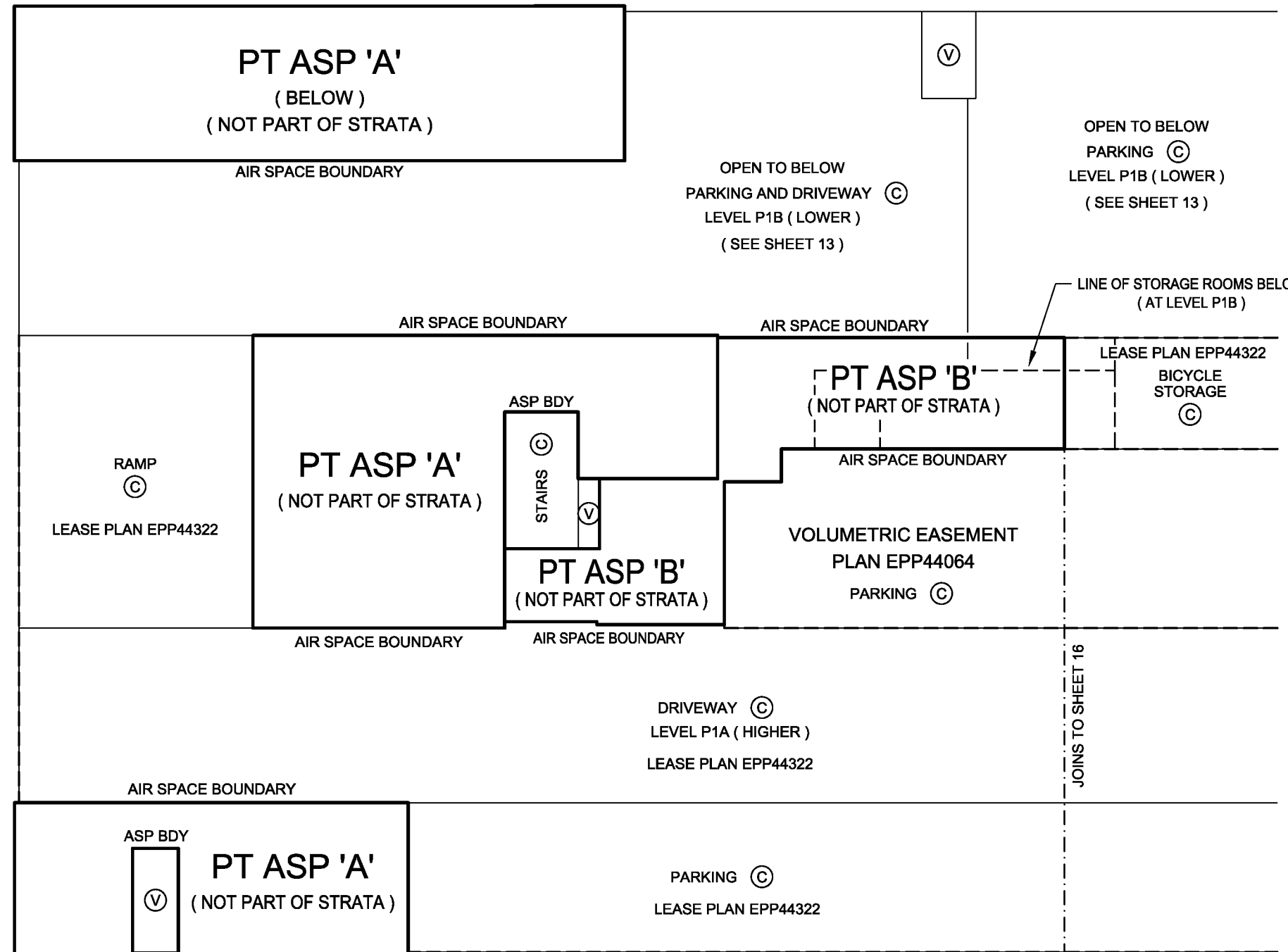

J. NEIL BENNETT, BCLS #527  
DECEMBER 1, 2014





# LEVEL 1 (GROUND ) FLOOR PLAN ( CENTRAL PORTION )

# STRATA PLAN EPS2328



ALL DISTANCES ARE IN METRES AND DECIMALS THEREOF.

THE INTENDED PLOT SIZE OF THIS PLAN IS  
280mm IN WIDTH BY 432mm IN HEIGHT (B SIZE)  
WHEN PLOTTED AT A SCALE OF 1:150.

ALL ANGLES ARE 45° OR 90° AND MULTIPLES THEREOF,  
UNLESS OTHERWISE NOTED.

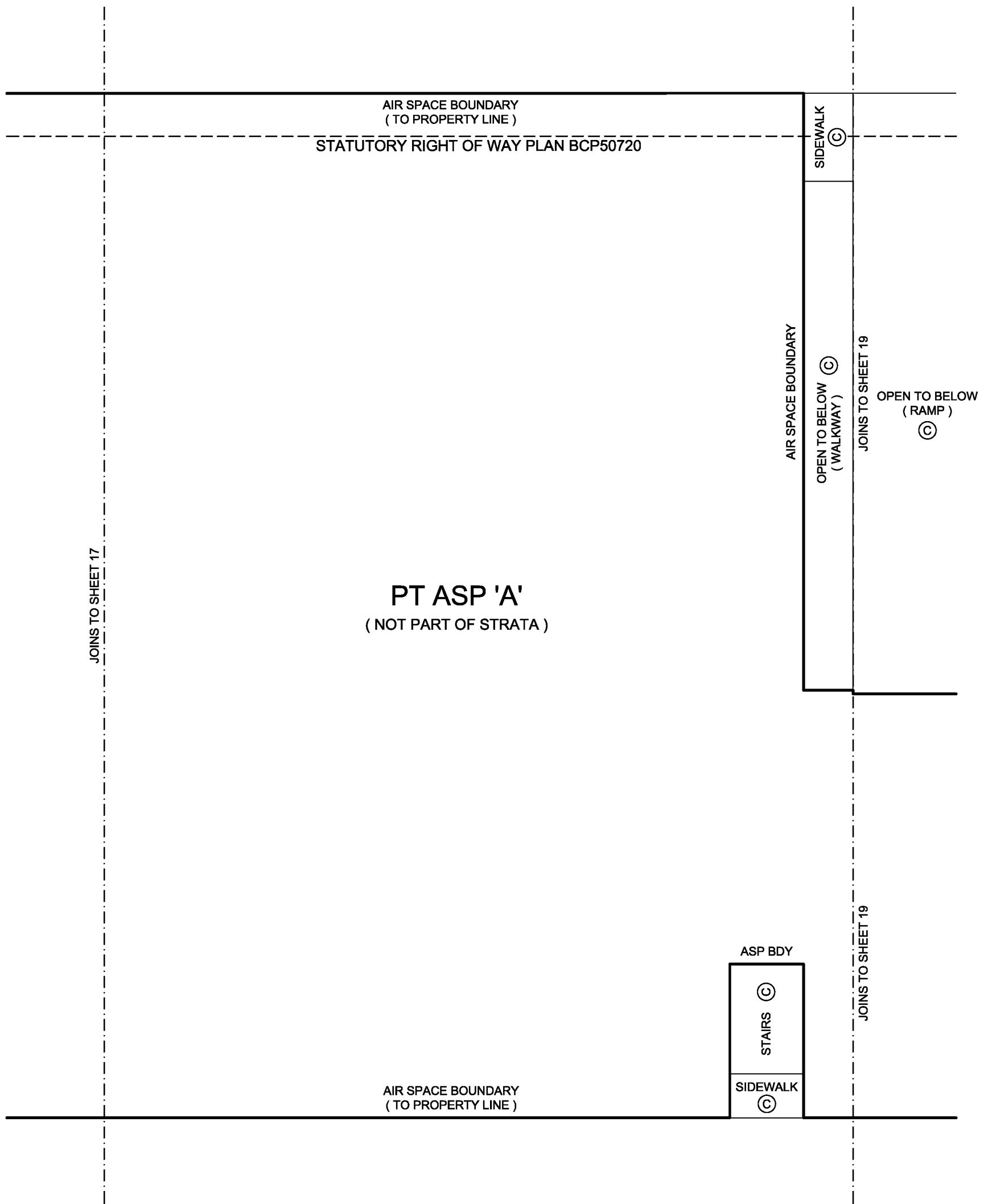

J. NEIL BENNETT, BCLS #527  
DECEMBER 1, 2014

# LEVEL 1 ( GROUND ) FLOOR PLAN ( EASTERN PORTION )

# STRATA PLAN EPS2328

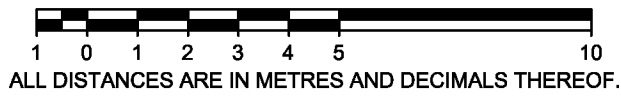

THE INTENDED PLOT SIZE OF THIS PLAN IS  
280mm IN WIDTH BY 432mm IN HEIGHT (B SIZE)  
WHEN PLOTTED AT A SCALE OF 1:150.

ALL ANGLES ARE 45° OR 90° AND MULTIPLES THEREOF,  
UNLESS OTHERWISE NOTED.

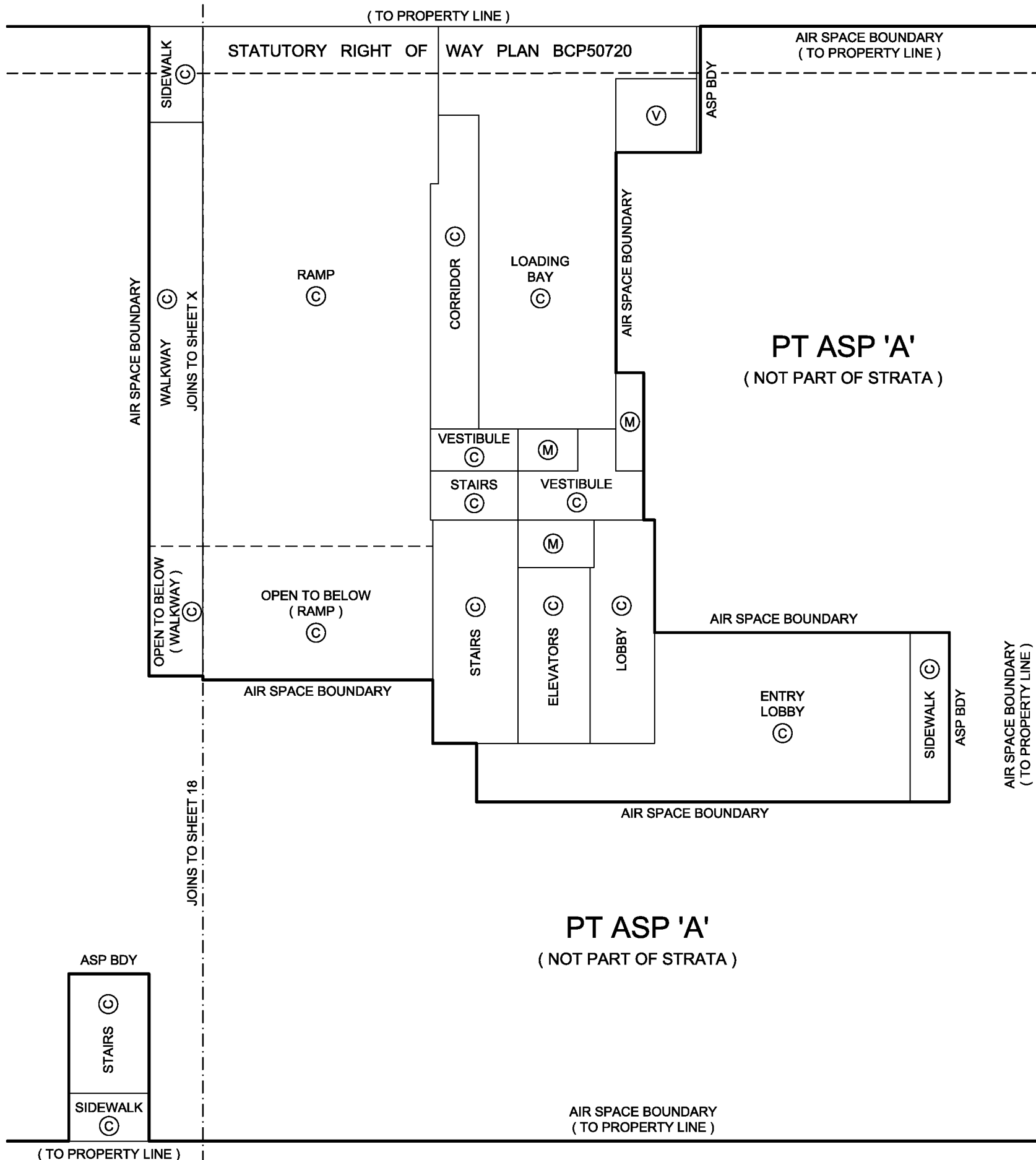
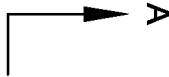

J. NEIL BENNETT, BCLS #527  
DECEMBER 1, 2014

# LEVEL 1 UPPER FLOOR PLAN ( WESTERN PORTION )

# STRATA PLAN EPS2328

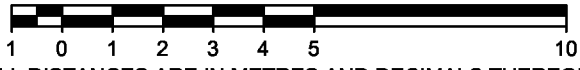

ALL DISTANCES ARE IN METRES AND DECIMALS THEREOF.

THE INTENDED PLOT SIZE OF THIS PLAN IS  
280mm IN WIDTH BY 432mm IN HEIGHT (B SIZE)  
WHEN PLOTTED AT A SCALE OF 1:150.

ALL ANGLES ARE 45° OR 90° AND MULTIPLES THEREOF,  
UNLESS OTHERWISE NOTED.

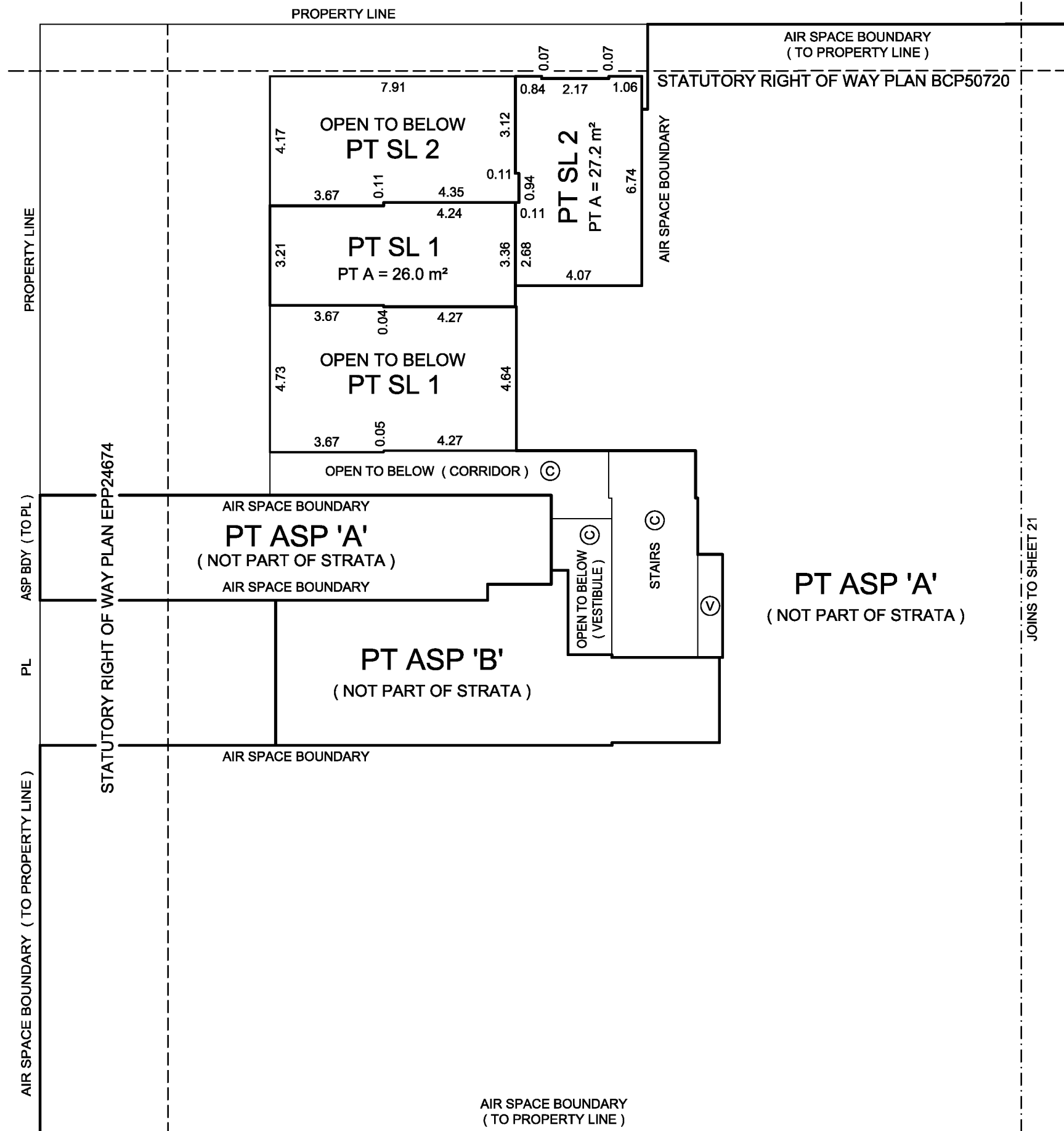

J. NEIL BENNETT, BCLS #527  
DECEMBER 1, 2014

# LEVEL 1 UPPER FLOOR PLAN ( CENTRAL PORTION )

# STRATA PLAN EPS2328

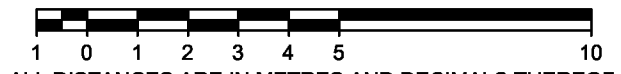

ALL DISTANCES ARE IN METRES AND DECIMALS THEREOF.

THE INTENDED PLOT SIZE OF THIS PLAN IS  
280mm IN WIDTH BY 432mm IN HEIGHT (B SIZE)  
WHEN PLOTTED AT A SCALE OF 1:150.

ALL ANGLES ARE 45° OR 90° AND MULTIPLES THEREOF,  
UNLESS OTHERWISE NOTED.

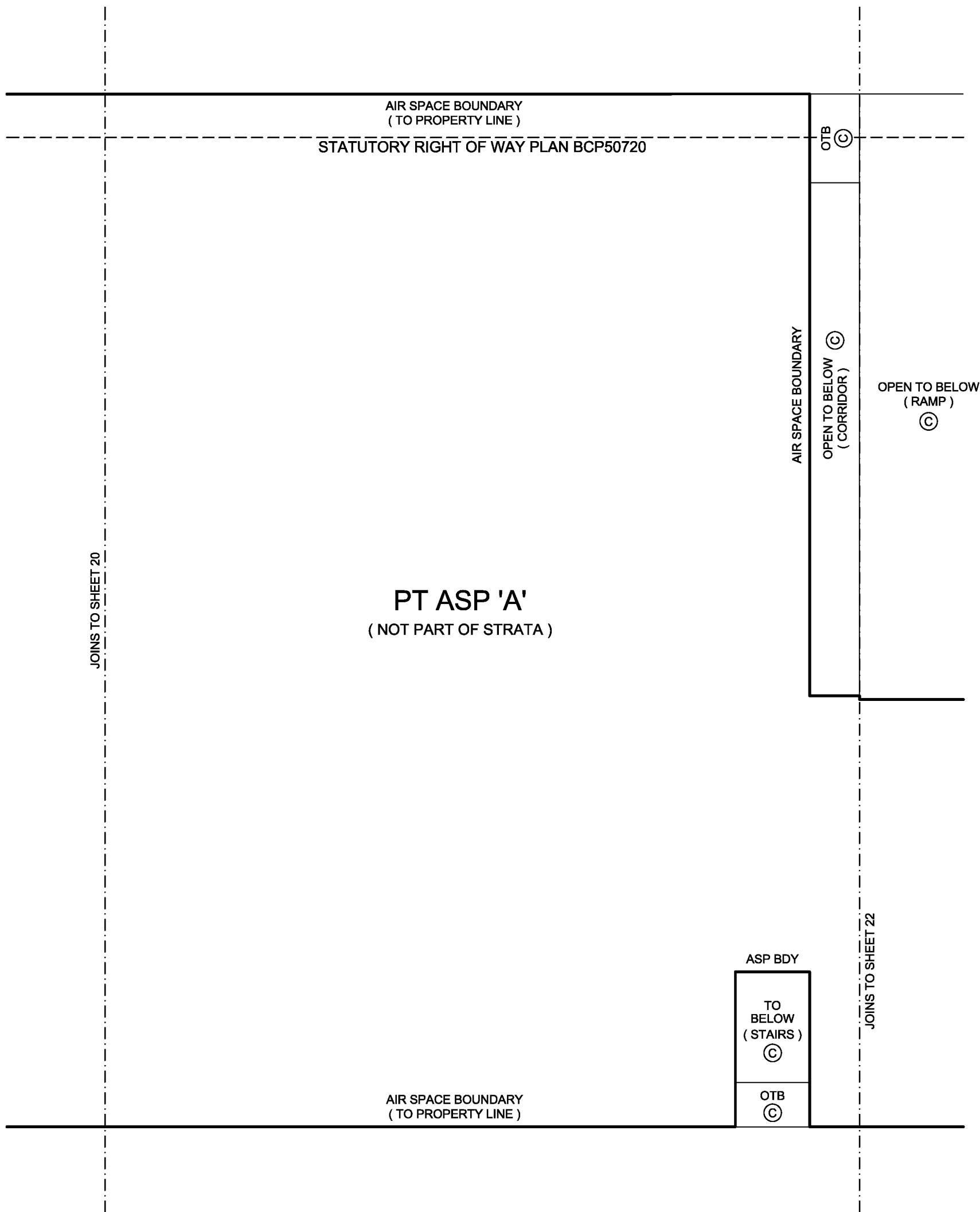

J. NEIL BENNETT, BCLS #527  
DECEMBER 1, 2014



# LEVEL 2 FLOOR PLAN ( WESTERN PORTION )

# STRATA PLAN EPS2328

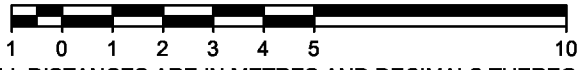

ALL DISTANCES ARE IN METRES AND DECIMALS THEREOF.

THE INTENDED PLOT SIZE OF THIS PLAN IS  
280mm IN WIDTH BY 432mm IN HEIGHT (B SIZE)  
WHEN PLOTTED AT A SCALE OF 1:150.

ALL ANGLES ARE 45° OR 90° AND MULTIPLES THEREOF,  
UNLESS OTHERWISE NOTED.

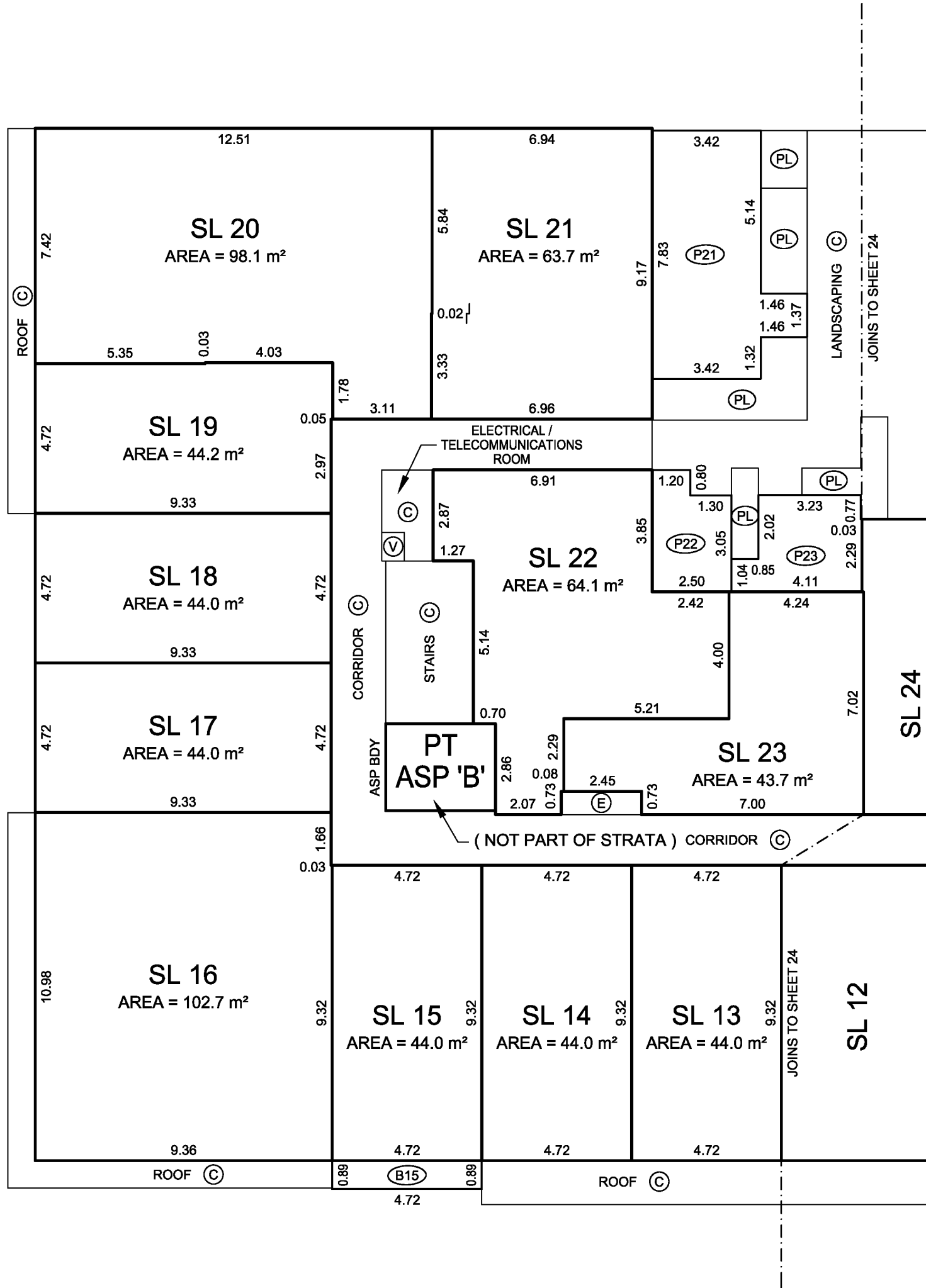
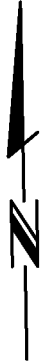

J. NEIL BENNETT, BCLS #527  
DECEMBER 1, 2014

# LEVEL 2 FLOOR PLAN ( CENTRAL PORTION )

# STRATA PLAN EPS2328

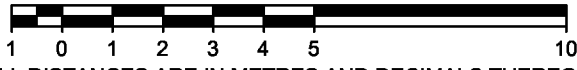

ALL DISTANCES ARE IN METRES AND DECIMALS THEREOF.

THE INTENDED PLOT SIZE OF THIS PLAN IS  
280mm IN WIDTH BY 432mm IN HEIGHT (B SIZE)  
WHEN PLOTTED AT A SCALE OF 1:150.

ALL ANGLES ARE 45° OR 90° AND MULTIPLES THEREOF,  
UNLESS OTHERWISE NOTED.

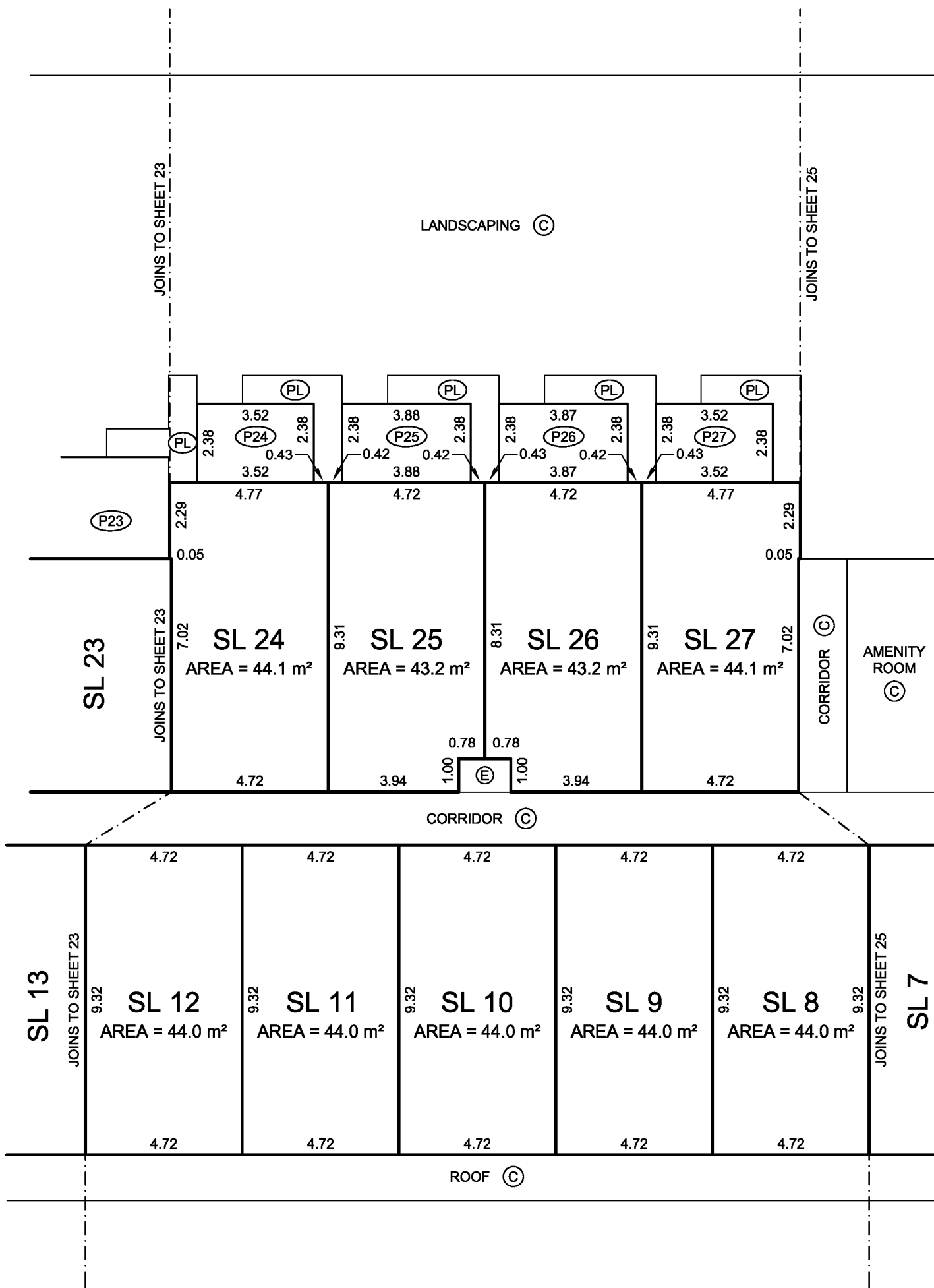
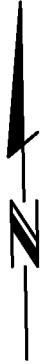

J. NEIL BENNETT, BCLS #527  
DECEMBER 1, 2014

# LEVEL 2 FLOOR PLAN ( EASTERN PORTION )

# STRATA PLAN EPS2328

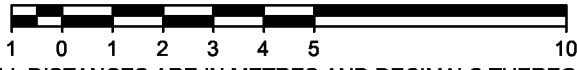

ALL DISTANCES ARE IN METRES AND DECIMALS THEREOF.

THE INTENDED PLOT SIZE OF THIS PLAN IS  
280mm IN WIDTH BY 432mm IN HEIGHT (B SIZE)  
WHEN PLOTTED AT A SCALE OF 1:150.

ALL ANGLES ARE 45° OR 90° AND MULTIPLES THEREOF,  
UNLESS OTHERWISE NOTED.

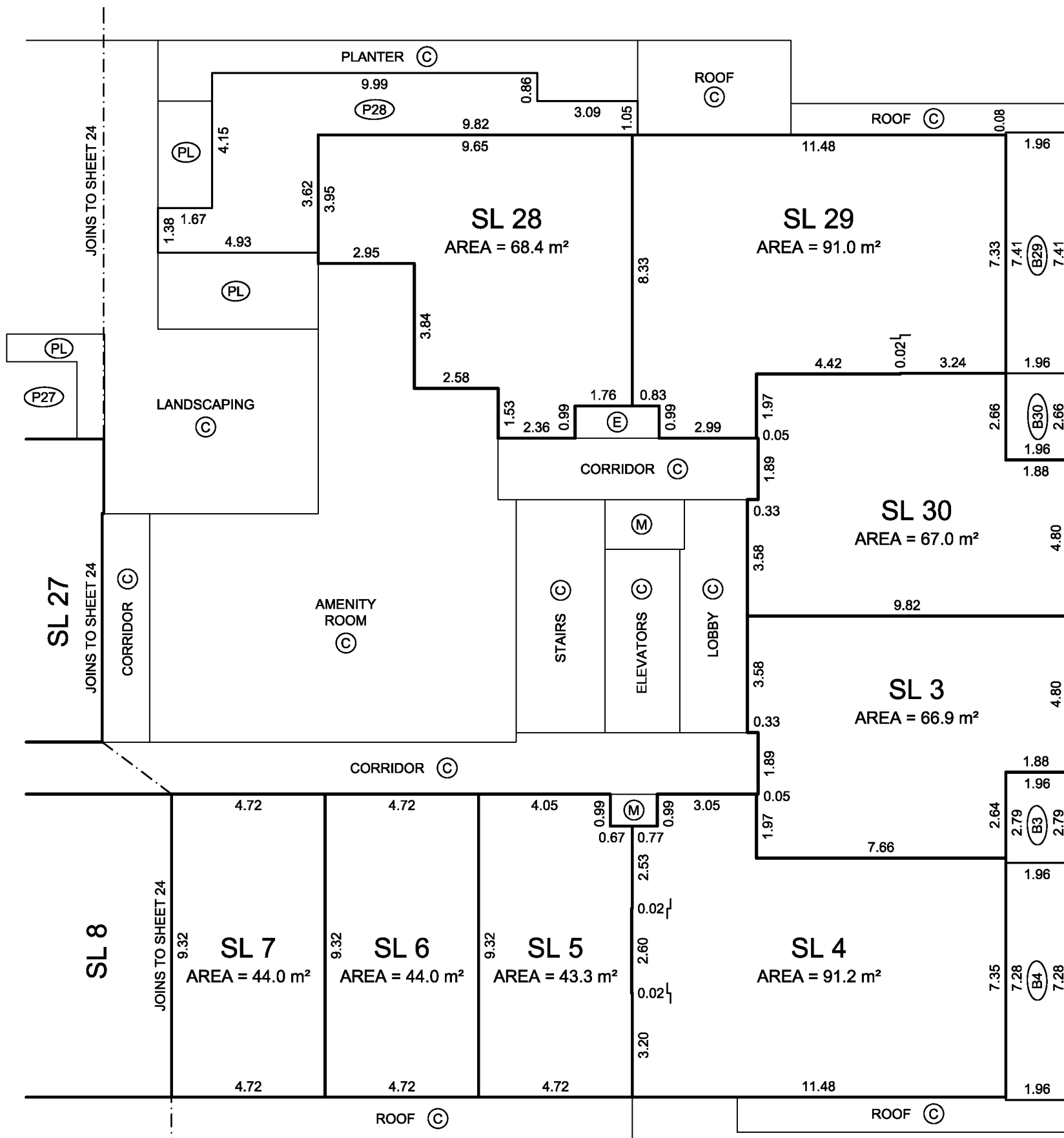

J. NEIL BENNETT, BCLS #527  
DECEMBER 1, 2014

# LEVEL 3 FLOOR PLAN ( WESTERN PORTION )

# STRATA PLAN EPS2328

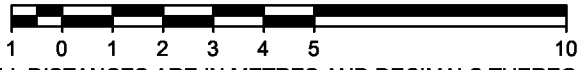

ALL DISTANCES ARE IN METRES AND DECIMALS THEREOF.

THE INTENDED PLOT SIZE OF THIS PLAN IS  
280mm IN WIDTH BY 432mm IN HEIGHT (B SIZE)  
WHEN PLOTTED AT A SCALE OF 1:150.

ALL ANGLES ARE 45° OR 90° AND MULTIPLES THEREOF,  
UNLESS OTHERWISE NOTED.

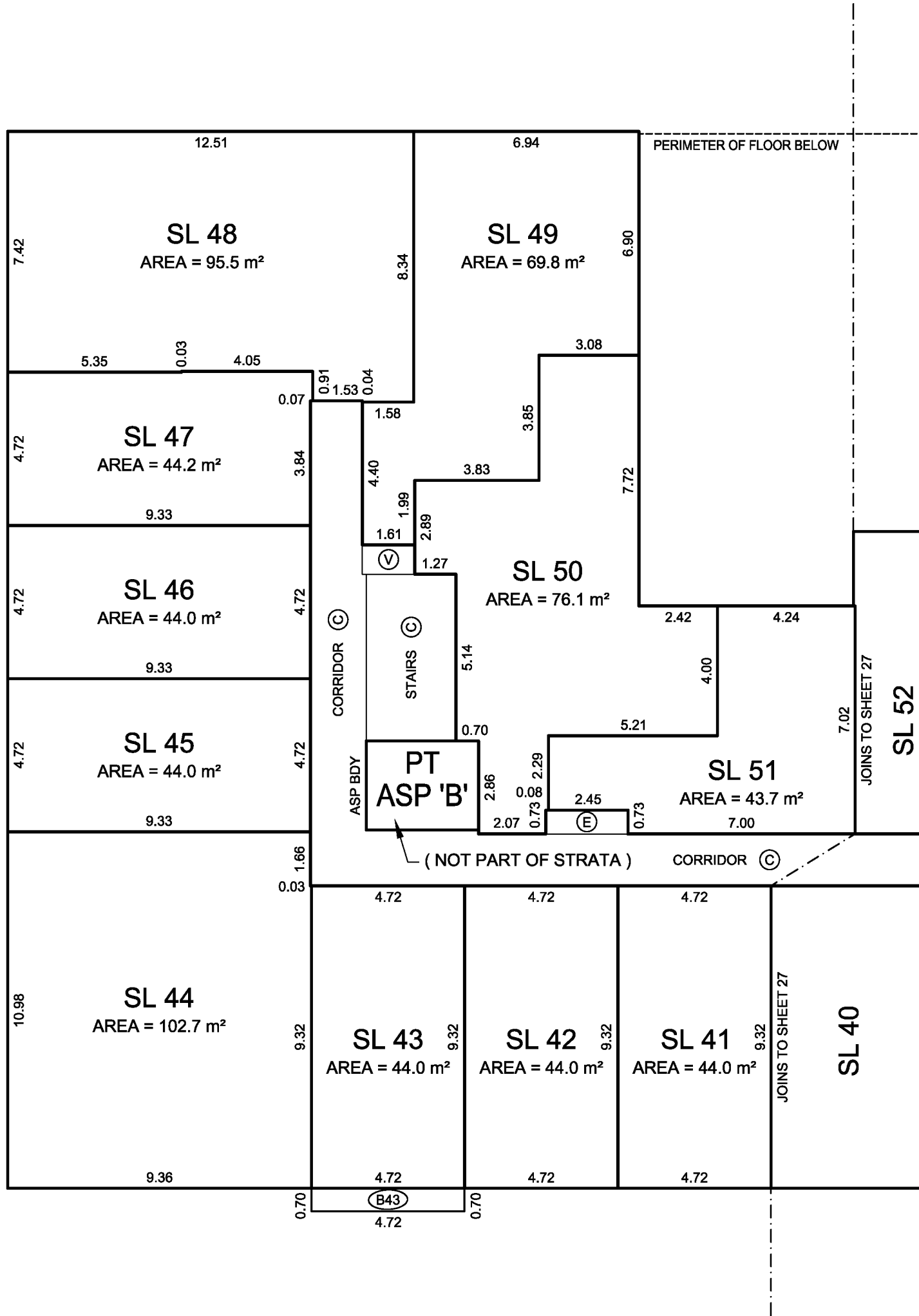
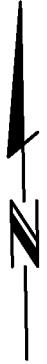

J. NEIL BENNETT, BCLS #527  
DECEMBER 1, 2014

# LEVEL 3 FLOOR PLAN ( CENTRAL PORTION )

# STRATA PLAN EPS2328



ALL DISTANCES ARE IN METRES AND DECIMALS THEREOF.

THE INTENDED PLOT SIZE OF THIS PLAN IS  
280mm IN WIDTH BY 432mm IN HEIGHT (B SIZE)  
WHEN PLOTTED AT A SCALE OF 1:150.

ALL ANGLES ARE 45° OR 90° AND MULTIPLES THEREOF,  
UNLESS OTHERWISE NOTED.

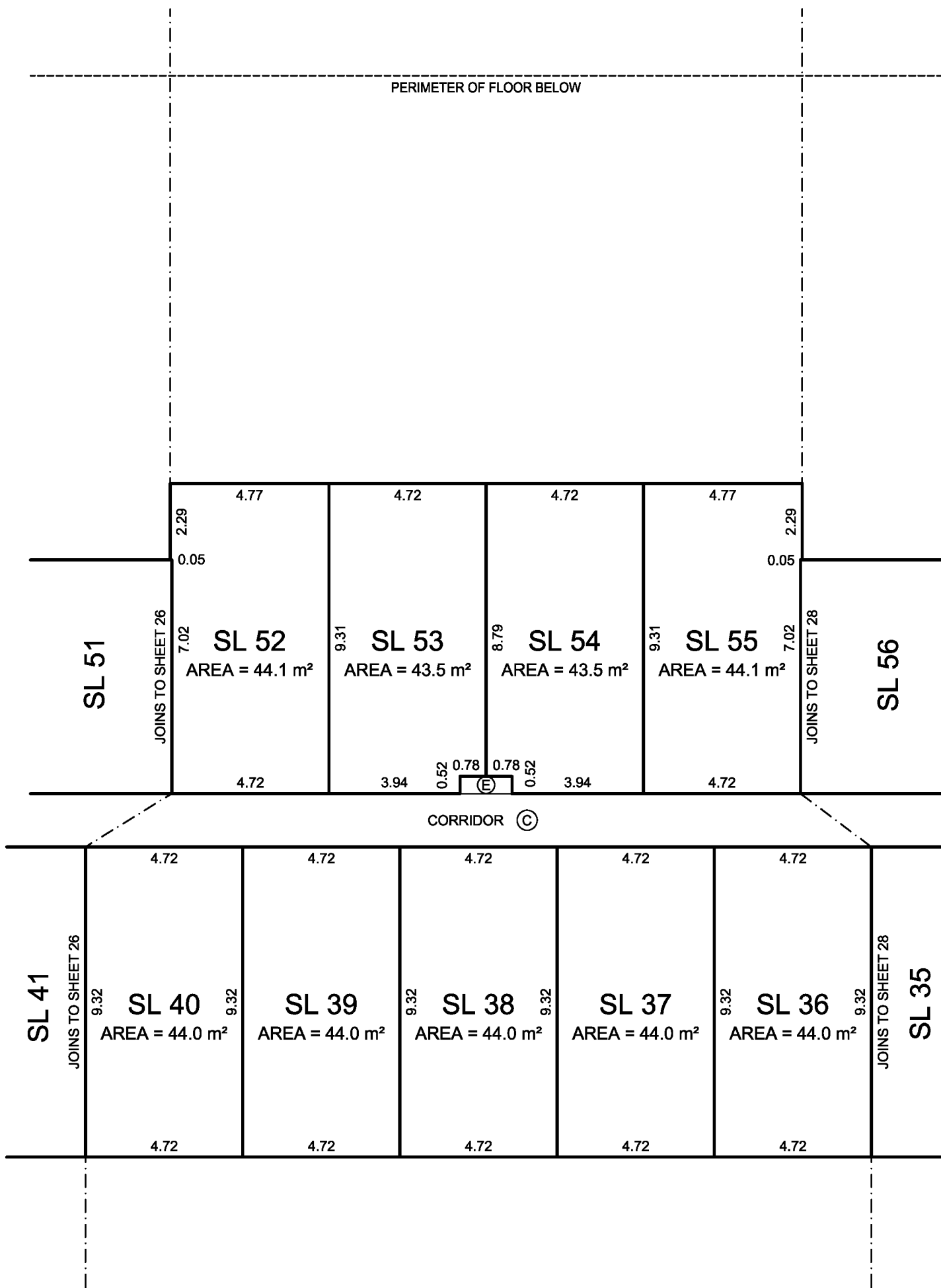
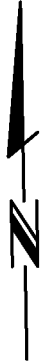

J. NEIL BENNETT, BCLS #527  
DECEMBER 1, 2014

# LEVEL 3 FLOOR PLAN ( EASTERN PORTION )

# STRATA PLAN EPS2328

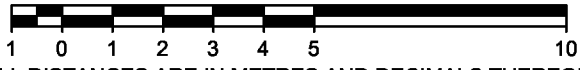

ALL DISTANCES ARE IN METRES AND DECIMALS THEREOF.

THE INTENDED PLOT SIZE OF THIS PLAN IS  
280mm IN WIDTH BY 432mm IN HEIGHT (B SIZE)  
WHEN PLOTTED AT A SCALE OF 1:150.

ALL ANGLES ARE 45° OR 90° AND MULTIPLES THEREOF,  
UNLESS OTHERWISE NOTED.

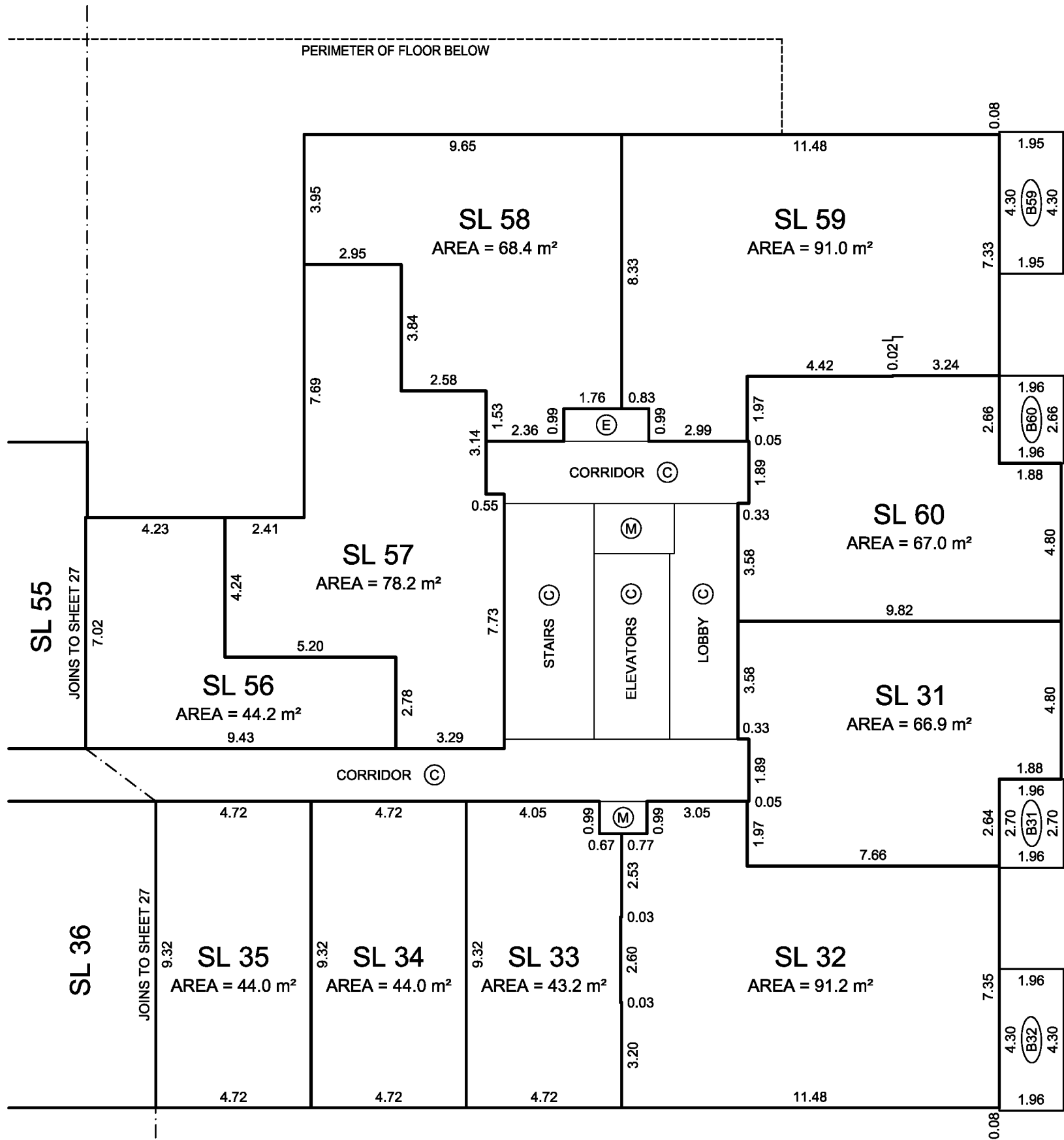
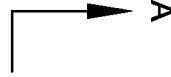
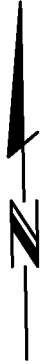

J. NEIL BENNETT, BCLS #527  
DECEMBER 1, 2014

# LEVEL 4 FLOOR PLAN ( DEVELOPER'S LEVEL 5 ) ( WESTERN PORTION )

# STRATA PLAN EPS2328



THE INTENDED PLOT SIZE OF THIS PLAN IS  
280mm IN WIDTH BY 432mm IN HEIGHT (B SIZE)  
WHEN PLOTTED AT A SCALE OF 1:150.

ALL ANGLES ARE 45° OR 90° AND MULTIPLES THEREOF,  
UNLESS OTHERWISE NOTED.

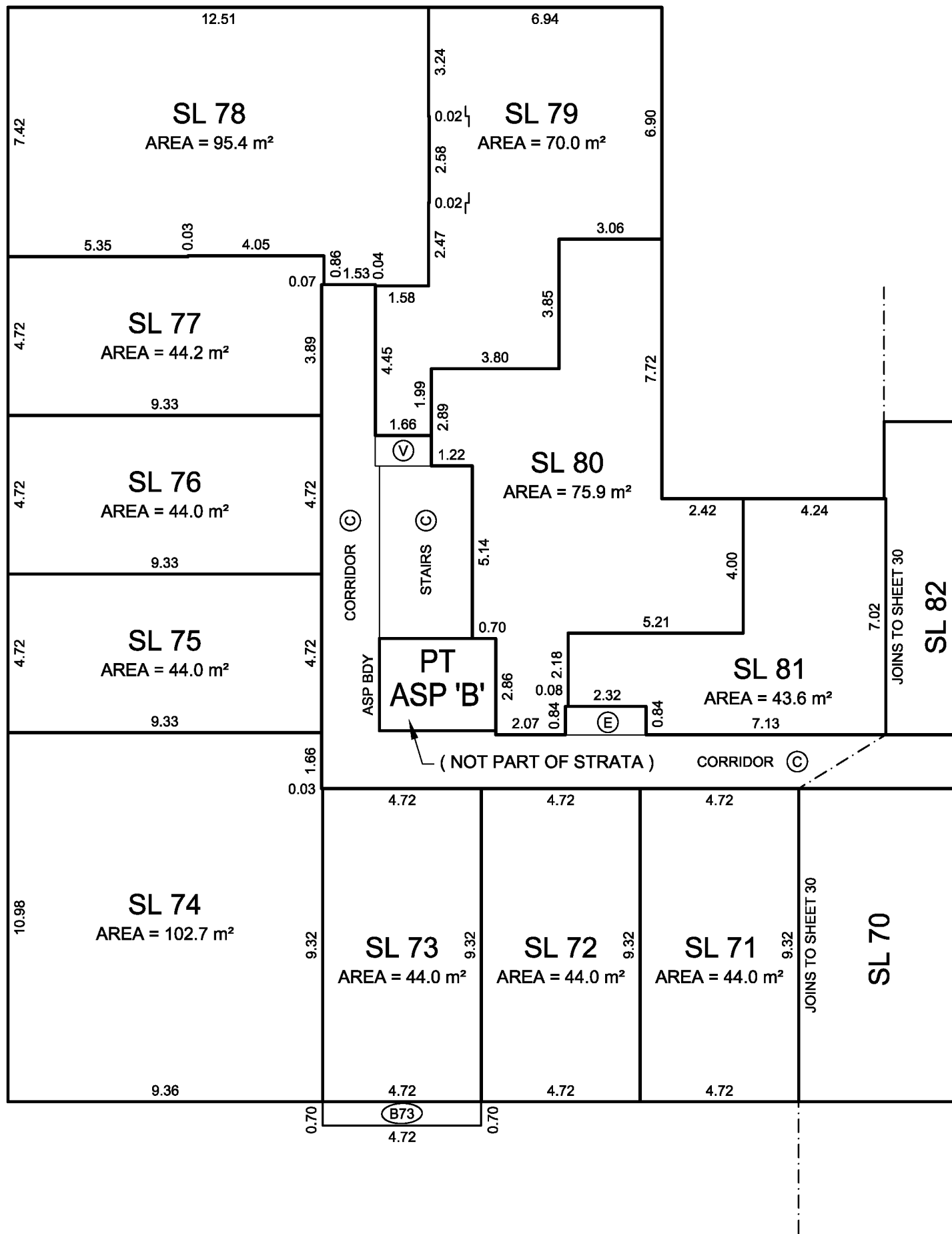
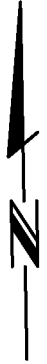

J. NEIL BENNETT, BCLS #527  
DECEMBER 1, 2014

# LEVEL 4 FLOOR PLAN ( DEVELOPER'S LEVEL 5 ) ( CENTRAL PORTION )

# STRATA PLAN EPS2328

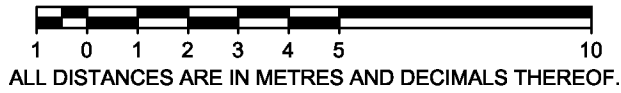

THE INTENDED PLOT SIZE OF THIS PLAN IS  
280mm IN WIDTH BY 432mm IN HEIGHT (B SIZE)  
WHEN PLOTTED AT A SCALE OF 1:150.

ALL ANGLES ARE 45° OR 90° AND MULTIPLES THEREOF,  
UNLESS OTHERWISE NOTED.

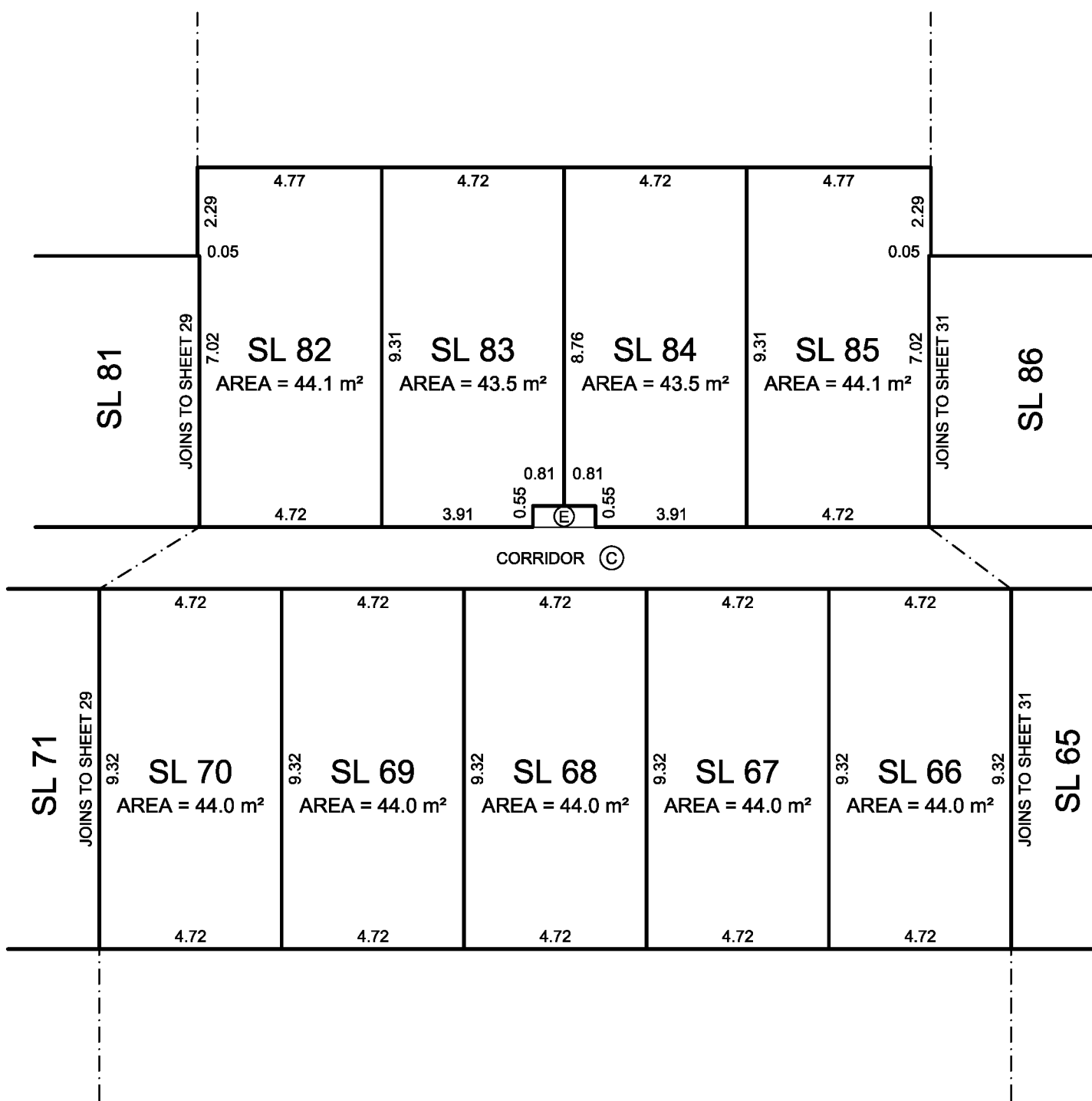
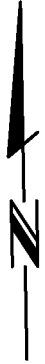

J. NEIL BENNETT, BCLS #527  
DECEMBER 1, 2014

# LEVEL 4 FLOOR PLAN ( DEVELOPER'S LEVEL 5 ) ( EASTERN PORTION )

# STRATA PLAN EPS2328

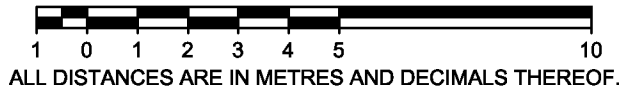

ALL DISTANCES ARE IN METRES AND DECIMALS THEREOF.

THE INTENDED PLOT SIZE OF THIS PLAN IS  
280mm IN WIDTH BY 432mm IN HEIGHT (B SIZE)  
WHEN PLOTTED AT A SCALE OF 1:150.

ALL ANGLES ARE 45° OR 90° AND MULTIPLES THEREOF,  
UNLESS OTHERWISE NOTED.

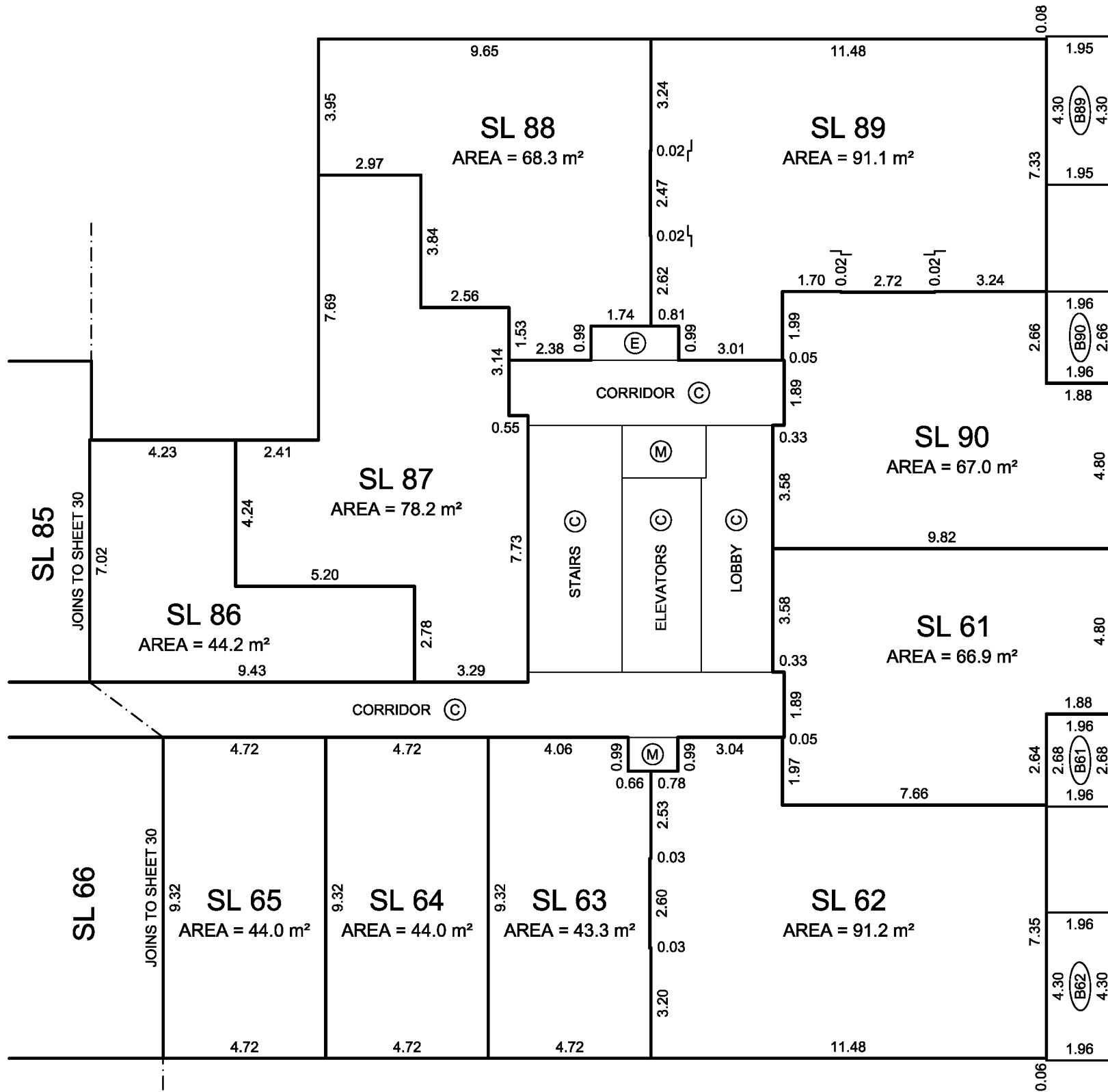
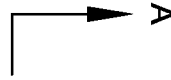
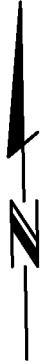

J. NEIL BENNETT, BCLS #527  
DECEMBER 1, 2014



# LEVEL 5 FLOOR PLAN ( DEVELOPER'S LEVEL 6 ) ( CENTRAL PORTION )

# STRATA PLAN EPS2328



ALL DISTANCES ARE IN METRES AND DECIMALS THEREOF.

THE INTENDED PLOT SIZE OF THIS PLAN IS  
280mm IN WIDTH BY 432mm IN HEIGHT (B SIZE)  
WHEN PLOTTED AT A SCALE OF 1:150.

ALL ANGLES ARE 45° OR 90° AND MULTIPLES THEREOF,  
UNLESS OTHERWISE NOTED.

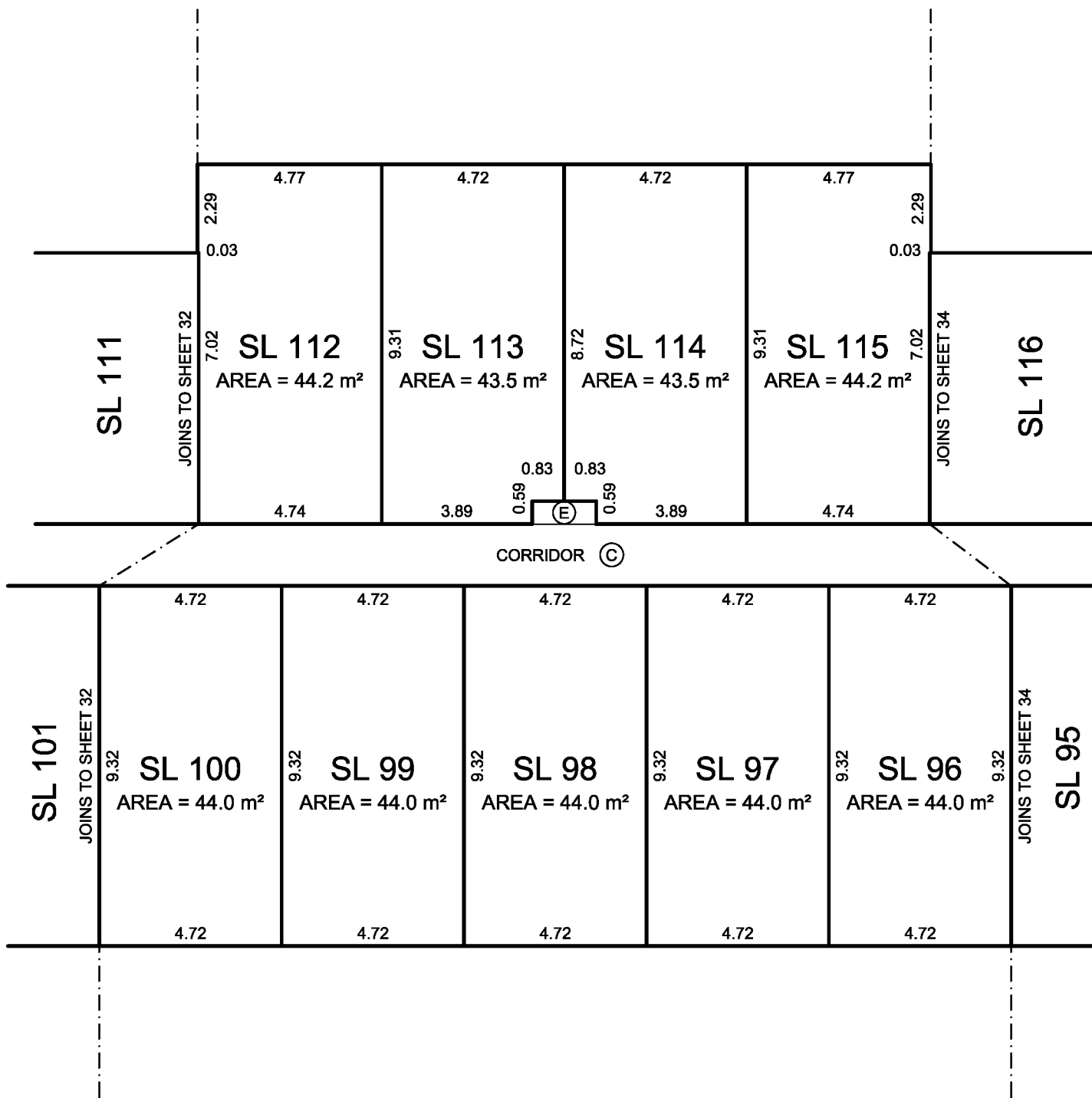
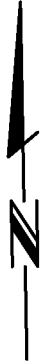

J. NEIL BENNETT, BCLS #527  
DECEMBER 1, 2014

# LEVEL 5 FLOOR PLAN ( DEVELOPER'S LEVEL 6 ) ( EASTERN PORTION )

# STRATA PLAN EPS2328

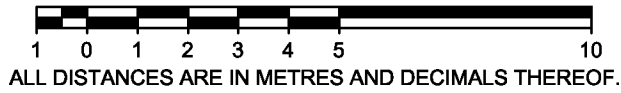

ALL DISTANCES ARE IN METRES AND DECIMALS THEREOF.

THE INTENDED PLOT SIZE OF THIS PLAN IS  
280mm IN WIDTH BY 432mm IN HEIGHT (B SIZE)  
WHEN PLOTTED AT A SCALE OF 1:150.

ALL ANGLES ARE 45° OR 90° AND MULTIPLES THEREOF,  
UNLESS OTHERWISE NOTED.

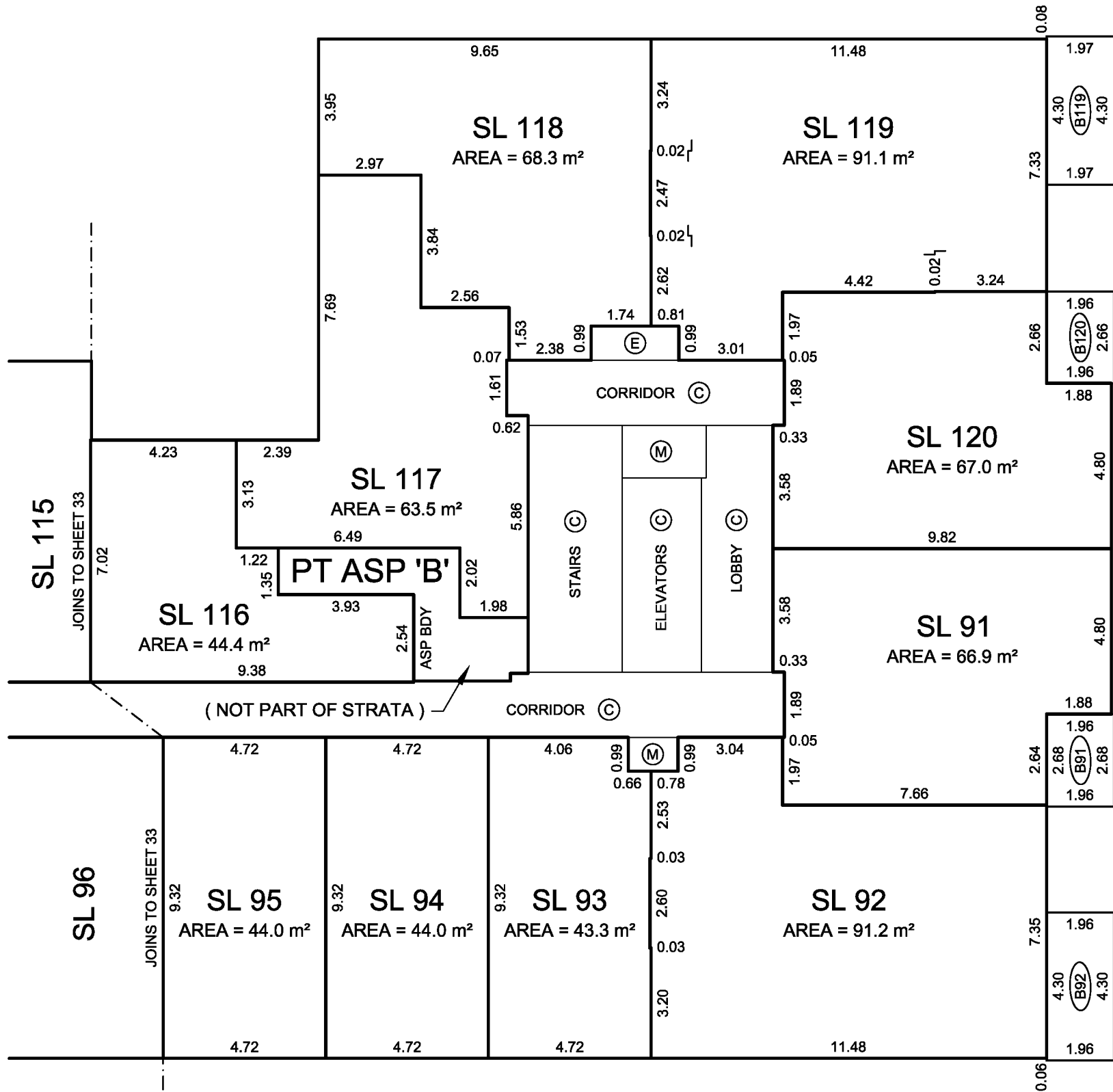
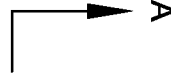
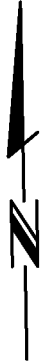

J. NEIL BENNETT, BCLS #527  
DECEMBER 1, 2014

# LEVEL 6 FLOOR PLAN ( DEVELOPER'S LEVEL 7 ) ( WESTERN PORTION )

# STRATA PLAN EPS2328

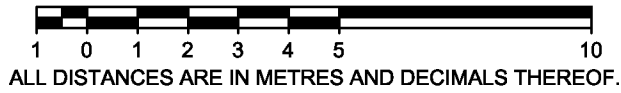

ALL DISTANCES ARE IN METRES AND DECIMALS THEREOF.

THE INTENDED PLOT SIZE OF THIS PLAN IS  
280mm IN WIDTH BY 432mm IN HEIGHT (B SIZE)  
WHEN PLOTTED AT A SCALE OF 1:150.

ALL ANGLES ARE 45° OR 90° AND MULTIPLES THEREOF,  
UNLESS OTHERWISE NOTED.

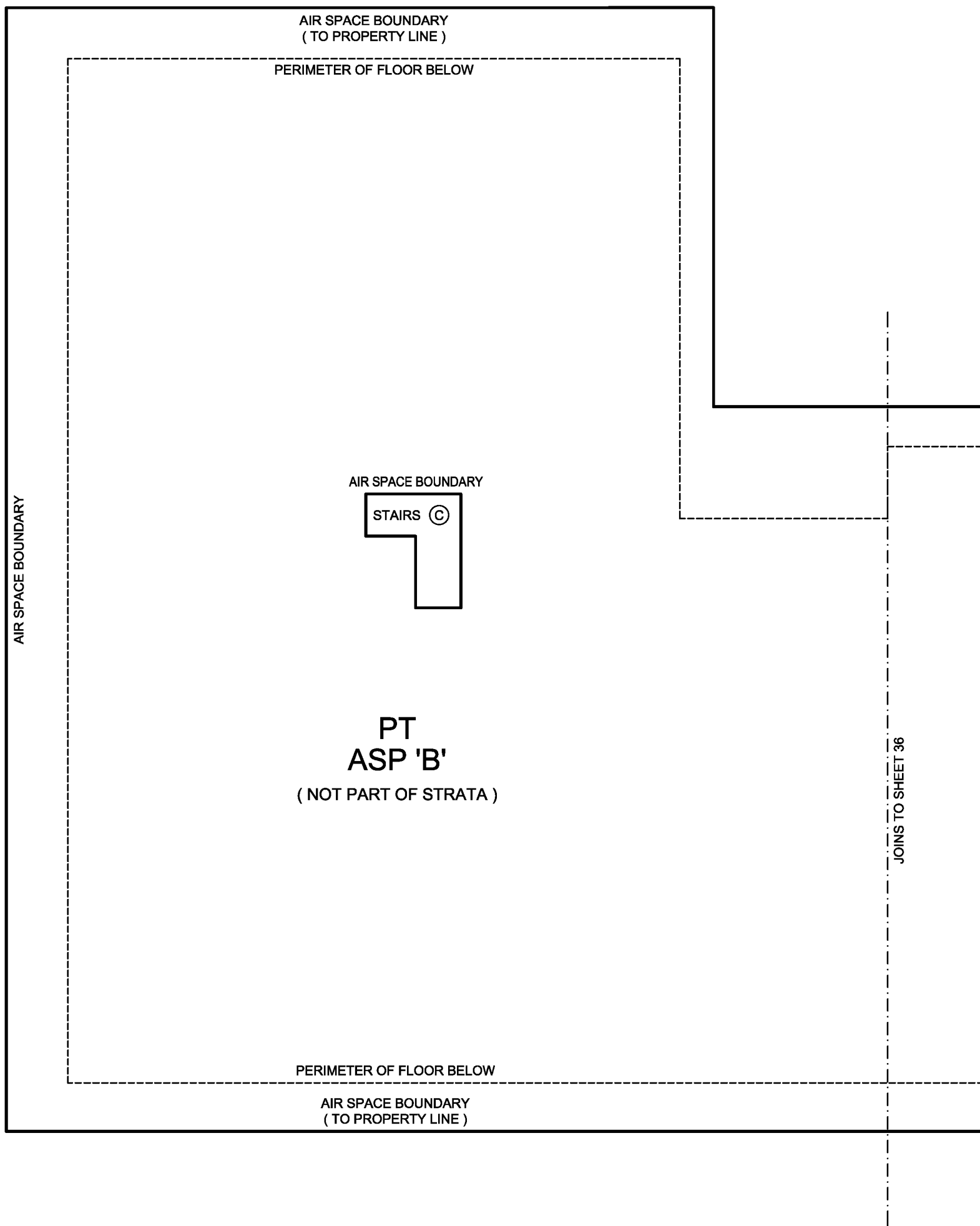

J. NEIL BENNETT, BCLS #527  
DECEMBER 1, 2014

**LEVEL 6 FLOOR PLAN  
( DEVELOPER'S LEVEL 7 )  
( CENTRAL PORTION )**

**STRATA PLAN EPS2328**

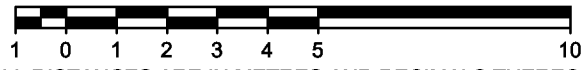

ALL DISTANCES ARE IN METRES AND DECIMALS THEREOF.

THE INTENDED PLOT SIZE OF THIS PLAN IS  
280mm IN WIDTH BY 432mm IN HEIGHT (B SIZE)  
WHEN PLOTTED AT A SCALE OF 1:150.

ALL ANGLES ARE 45° OR 90° AND MULTIPLES THEREOF,  
UNLESS OTHERWISE NOTED.

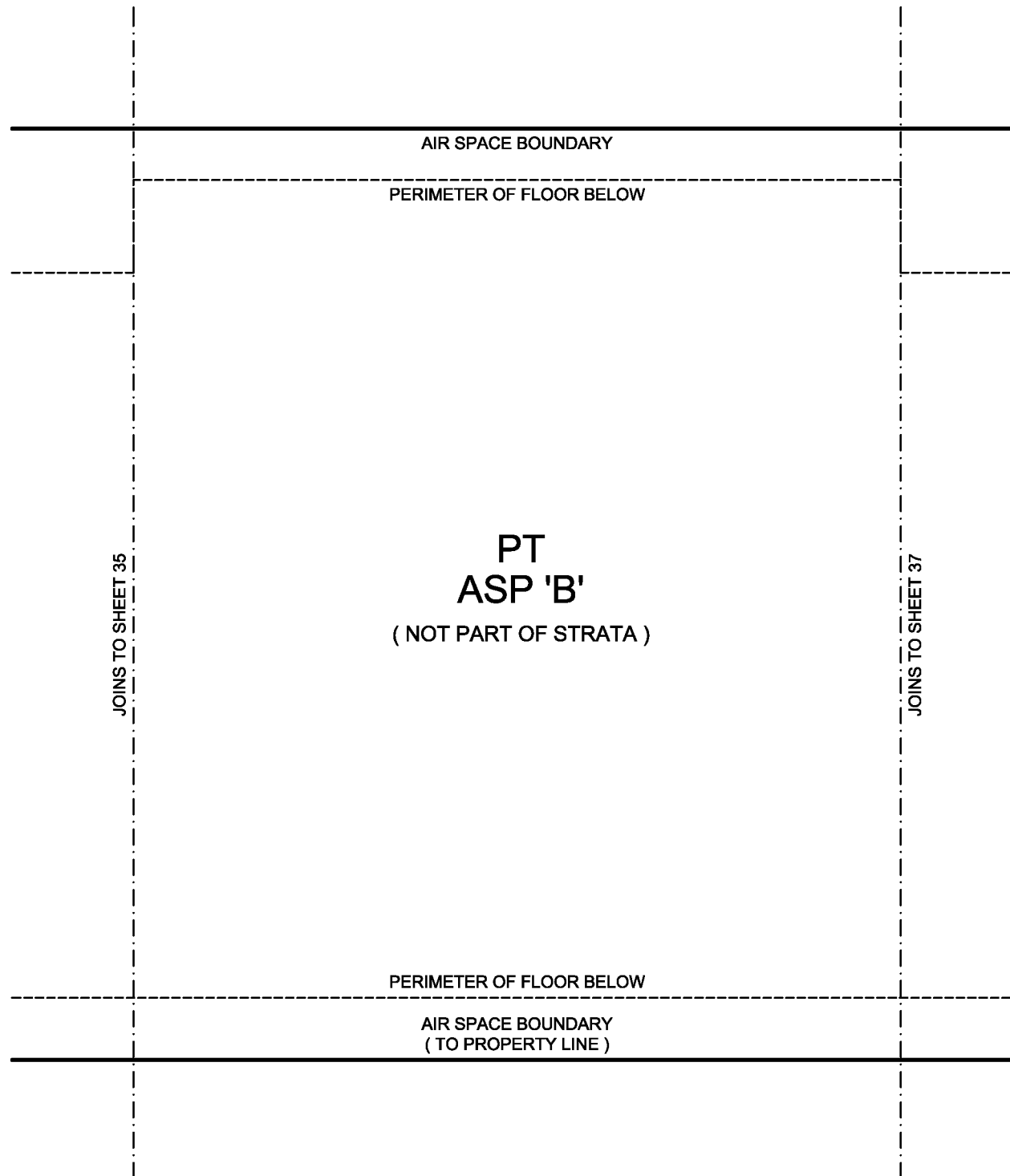

J. NEIL BENNETT, BCLS #527  
DECEMBER 1, 2014

# LEVEL 6 FLOOR PLAN ( DEVELOPER'S LEVEL 7 ) ( EASTERN PORTION )

# STRATA PLAN EPS2328

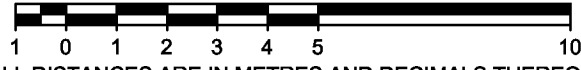

ALL DISTANCES ARE IN METRES AND DECIMALS THEREOF.

THE INTENDED PLOT SIZE OF THIS PLAN IS  
280mm IN WIDTH BY 432mm IN HEIGHT (B SIZE)  
WHEN PLOTTED AT A SCALE OF 1:150.

ALL ANGLES ARE 45° OR 90° AND MULTIPLES THEREOF,  
UNLESS OTHERWISE NOTED.

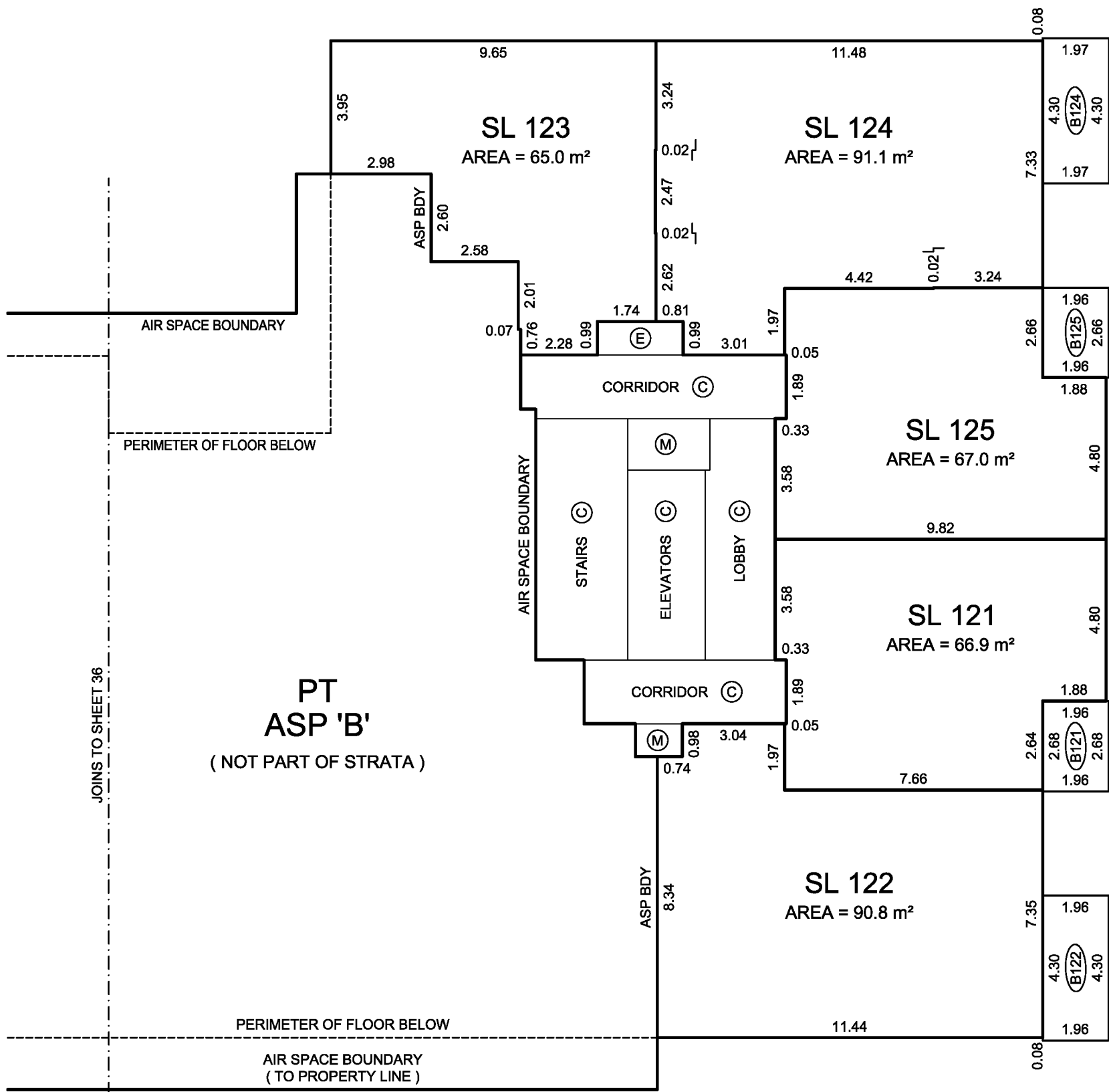
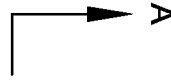
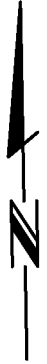

JOINS TO SHEET 36

PT  
ASP 'B'  
( NOT PART OF STRATA )

J. NEIL BENNETT, BCLS #527  
DECEMBER 1, 2014

**LEVEL 7 FLOOR PLAN  
( DEVELOPER'S LEVEL 8 )  
( WESTERN PORTION )**

**STRATA PLAN EPS2328**



ALL DISTANCES ARE IN METRES AND DECIMALS THEREOF.

THE INTENDED PLOT SIZE OF THIS PLAN IS  
432mm IN WIDTH BY 280mm IN HEIGHT (B SIZE)  
WHEN PLOTTED AT A SCALE OF 1:150.

ALL ANGLES ARE 45° OR 90° AND MULTIPLES THEREOF,  
UNLESS OTHERWISE NOTED.

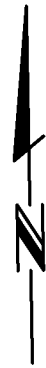

J. NEIL BENNETT, BCLS #527  
DECEMBER 1, 2014

# LEVEL 7 FLOOR PLAN ( DEVELOPER'S LEVEL 8 ) ( EASTERN PORTION )

# STRATA PLAN EPS2328

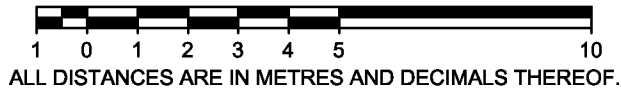

ALL DISTANCES ARE IN METRES AND DECIMALS THEREOF.

THE INTENDED PLOT SIZE OF THIS PLAN IS  
280mm IN WIDTH BY 432mm IN HEIGHT (B SIZE)  
WHEN PLOTTED AT A SCALE OF 1:150.

ALL ANGLES ARE 45° OR 90° AND MULTIPLES THEREOF,  
UNLESS OTHERWISE NOTED.

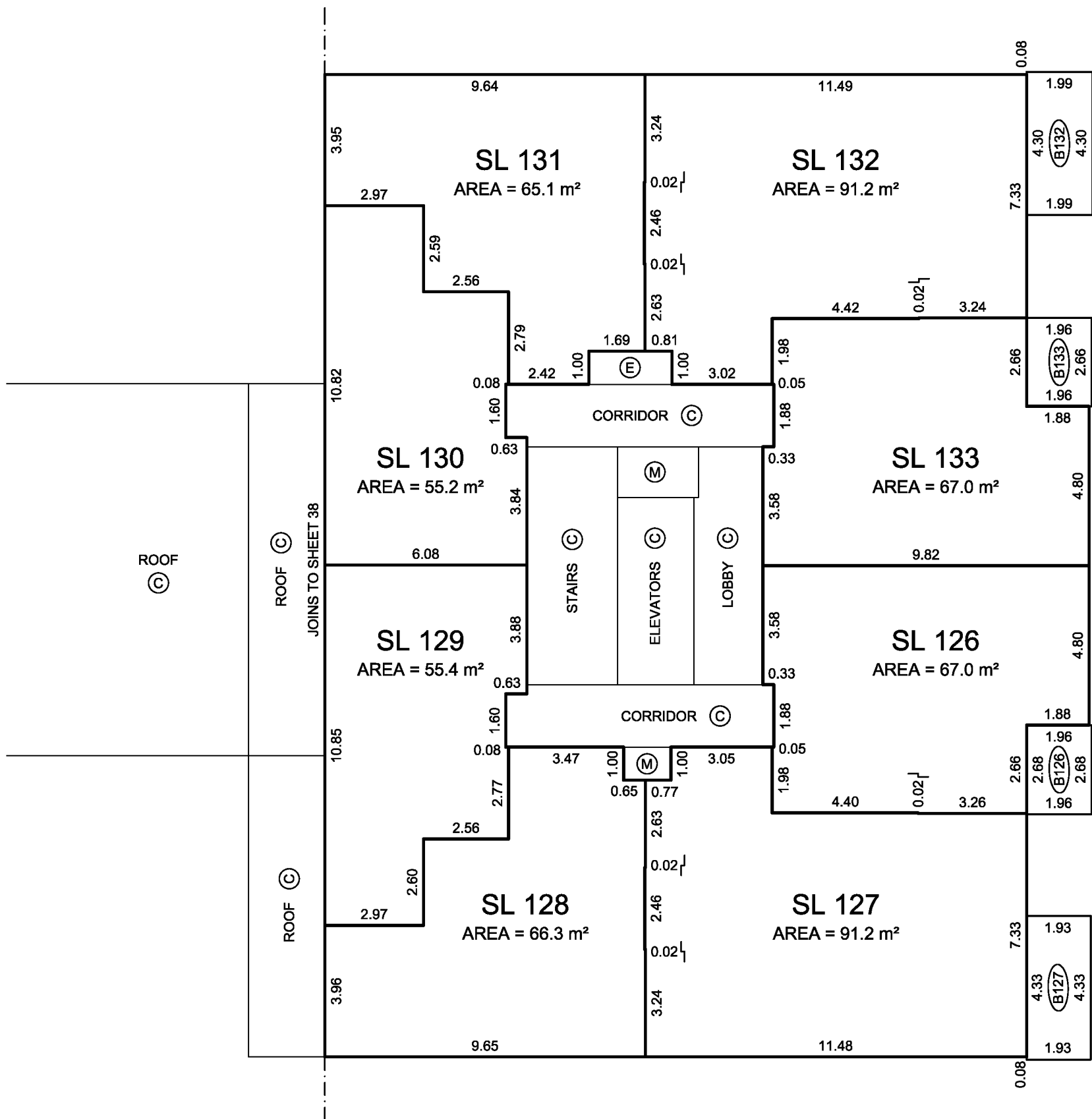
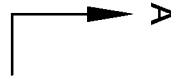

J. NEIL BENNETT, BCLS #527  
DECEMBER 1, 2014

# LEVEL 8 FLOOR PLAN ( DEVELOPER'S LEVEL 9 )

# STRATA PLAN EPS2328

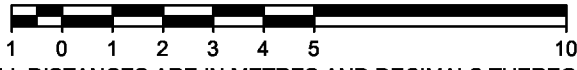

ALL DISTANCES ARE IN METRES AND DECIMALS THEREOF.

THE INTENDED PLOT SIZE OF THIS PLAN IS  
280mm IN WIDTH BY 432mm IN HEIGHT (B SIZE)  
WHEN PLOTTED AT A SCALE OF 1:150.

ALL ANGLES ARE 45° OR 90° AND MULTIPLES THEREOF,  
UNLESS OTHERWISE NOTED.

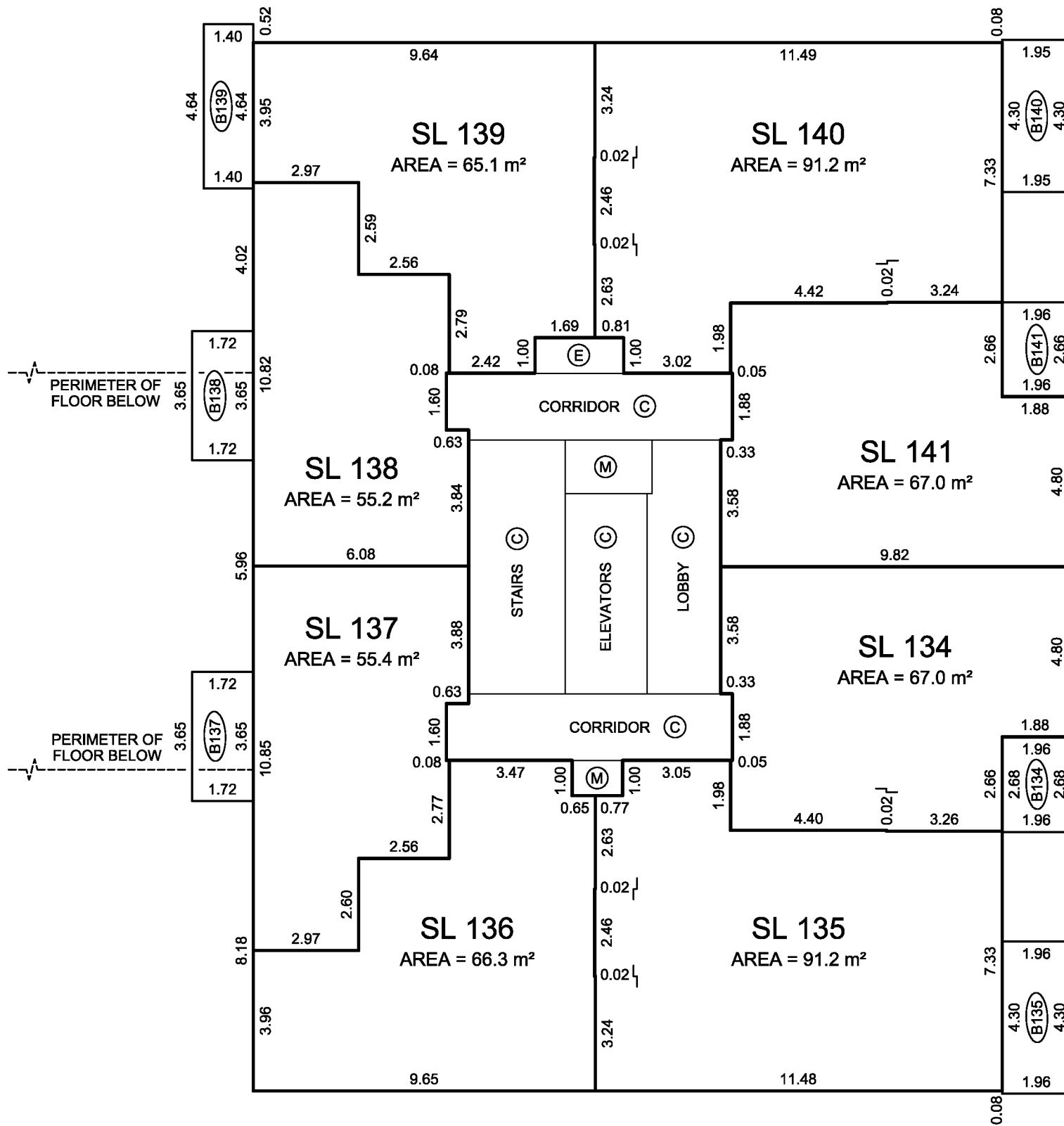
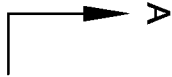

J. NEIL BENNETT, BCLS #527  
DECEMBER 1, 2014

# LEVEL 9 FLOOR PLAN ( DEVELOPER'S LEVEL 10 )

# STRATA PLAN EPS2328



THE INTENDED PLOT SIZE OF THIS PLAN IS  
280mm IN WIDTH BY 432mm IN HEIGHT (B SIZE)  
WHEN PLOTTED AT A SCALE OF 1:150.

ALL ANGLES ARE 45° OR 90° AND MULTIPLES THEREOF,  
UNLESS OTHERWISE NOTED.

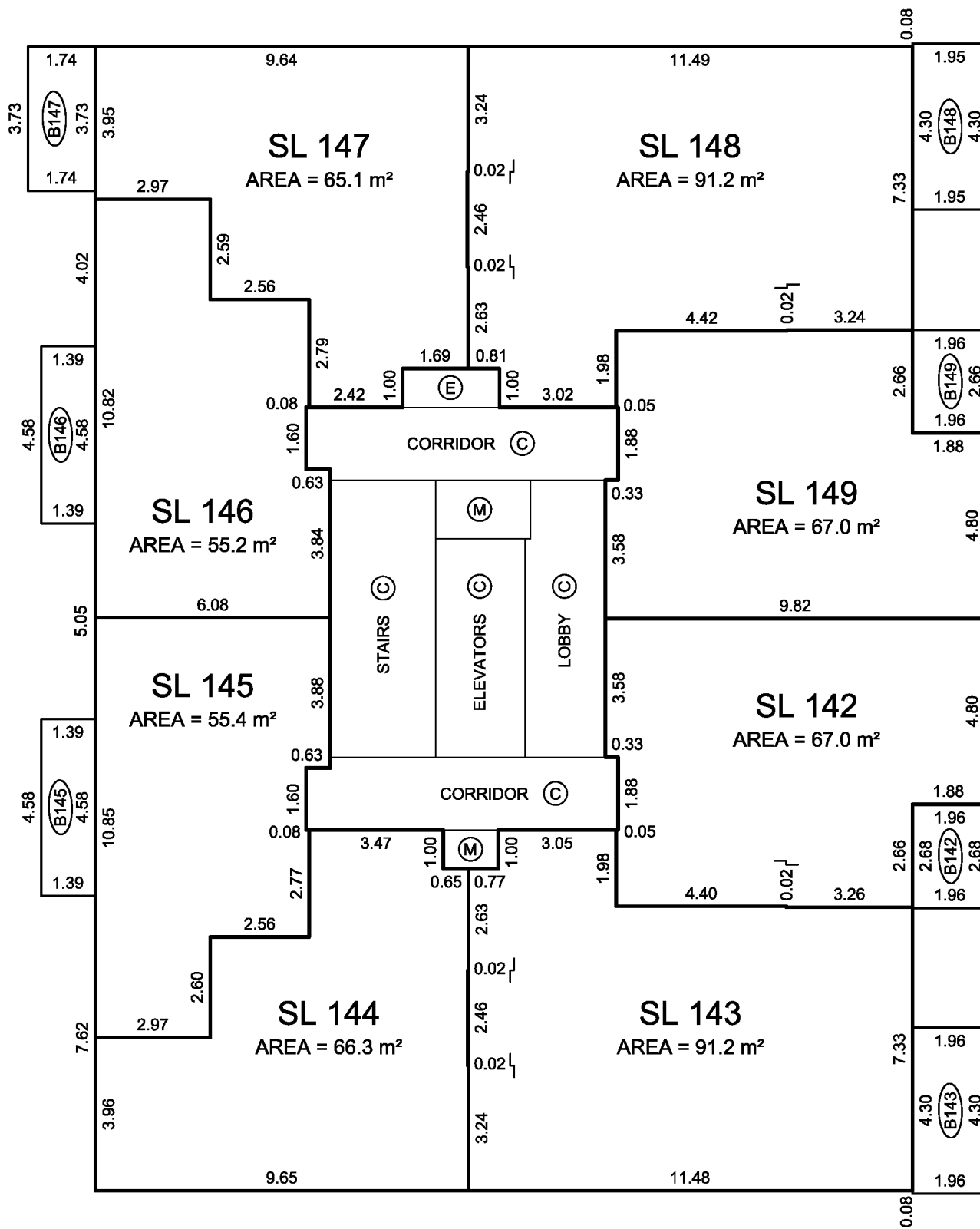
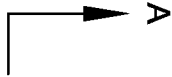

J. NEIL BENNETT, BCLS #527  
DECEMBER 1, 2014

# LEVEL 10 FLOOR PLAN ( DEVELOPER'S LEVEL 11 )

# STRATA PLAN EPS2328



THE INTENDED PLOT SIZE OF THIS PLAN IS  
280mm IN WIDTH BY 432mm IN HEIGHT (B SIZE)  
WHEN PLOTTED AT A SCALE OF 1:150.

ALL ANGLES ARE 45° OR 90° AND MULTIPLES THEREOF,  
UNLESS OTHERWISE NOTED.

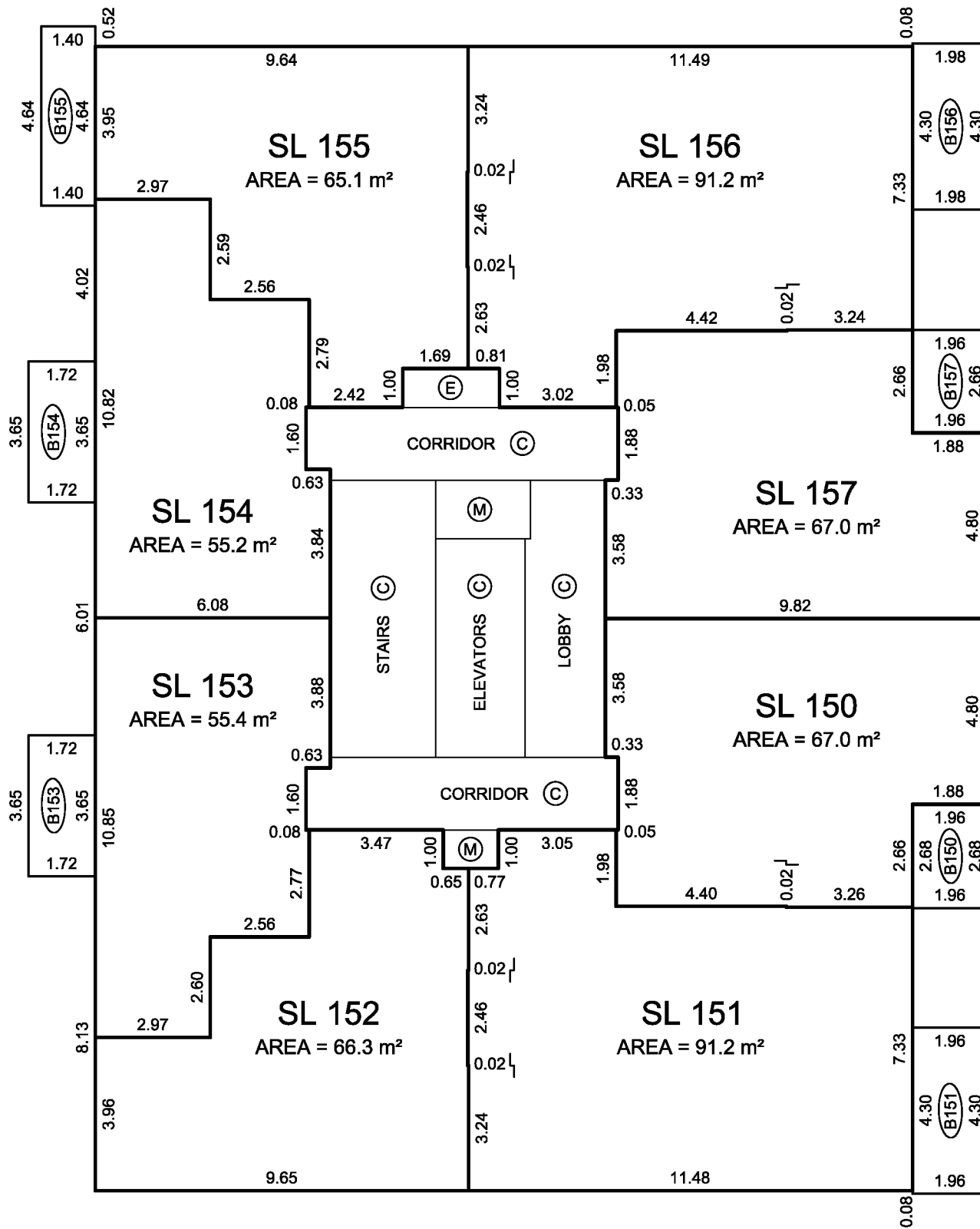
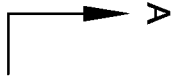

J. NEIL BENNETT, BCLS #527  
DECEMBER 1, 2014





# LEVEL 13 FLOOR PLAN ( DEVELOPER'S LEVEL 15 )

# STRATA PLAN EPS2328



THE INTENDED PLOT SIZE OF THIS PLAN IS  
280mm IN WIDTH BY 432mm IN HEIGHT (B SIZE)  
WHEN PLOTTED AT A SCALE OF 1:150.

ALL ANGLES ARE 45° OR 90° AND MULTIPLES THEREOF,  
UNLESS OTHERWISE NOTED.

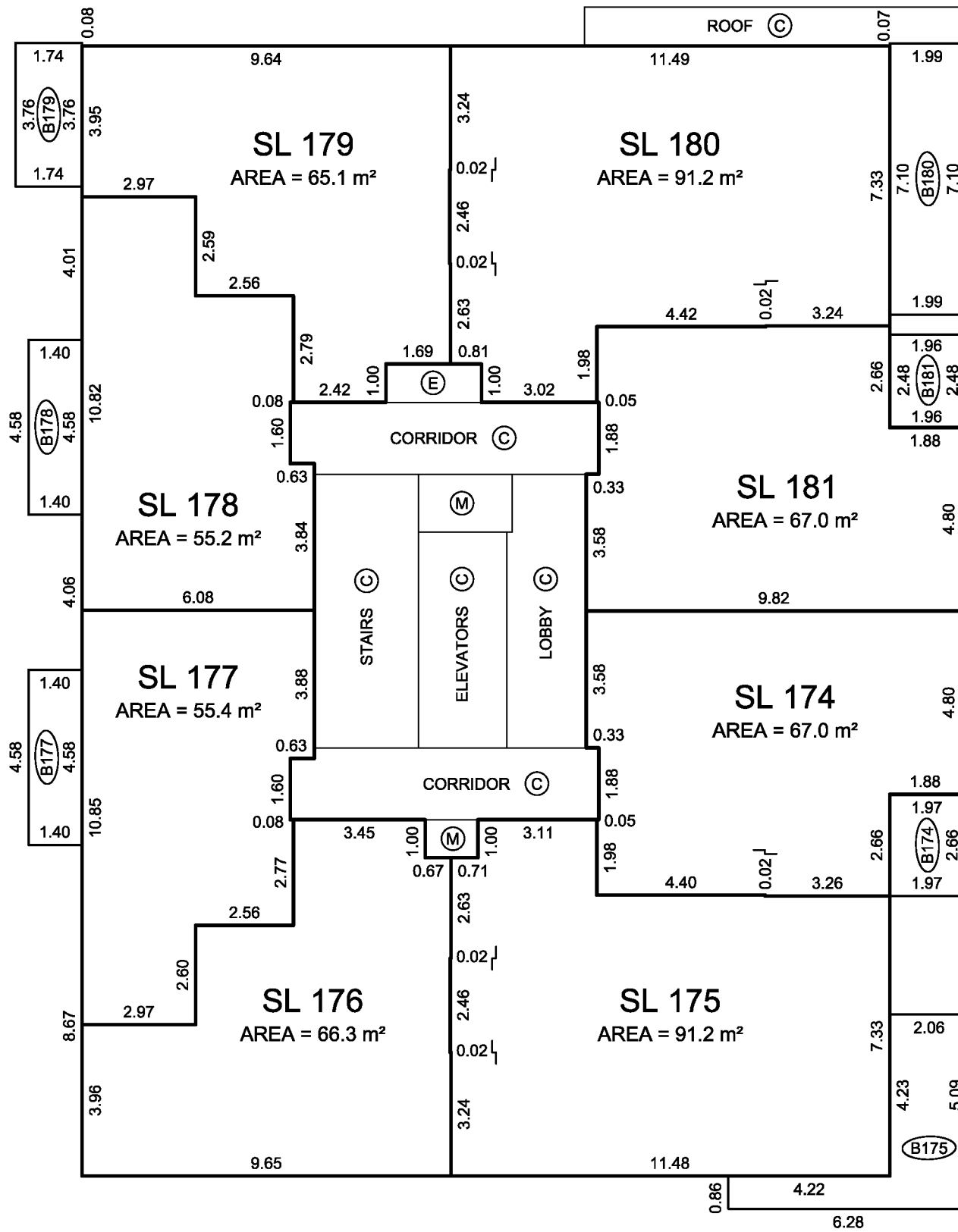
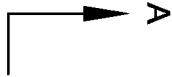

J. NEIL BENNETT, BCLS #527  
DECEMBER 1, 2014

# LEVEL 14 FLOOR PLAN ( DEVELOPER'S LEVEL 16 )

# STRATA PLAN EPS2328



ALL DISTANCES ARE IN METRES AND DECIMALS THEREOF.

THE INTENDED PLOT SIZE OF THIS PLAN IS  
280mm IN WIDTH BY 432mm IN HEIGHT (B SIZE)  
WHEN PLOTTED AT A SCALE OF 1:150.

ALL ANGLES ARE 45° OR 90° AND MULTIPLES THEREOF,  
UNLESS OTHERWISE NOTED.

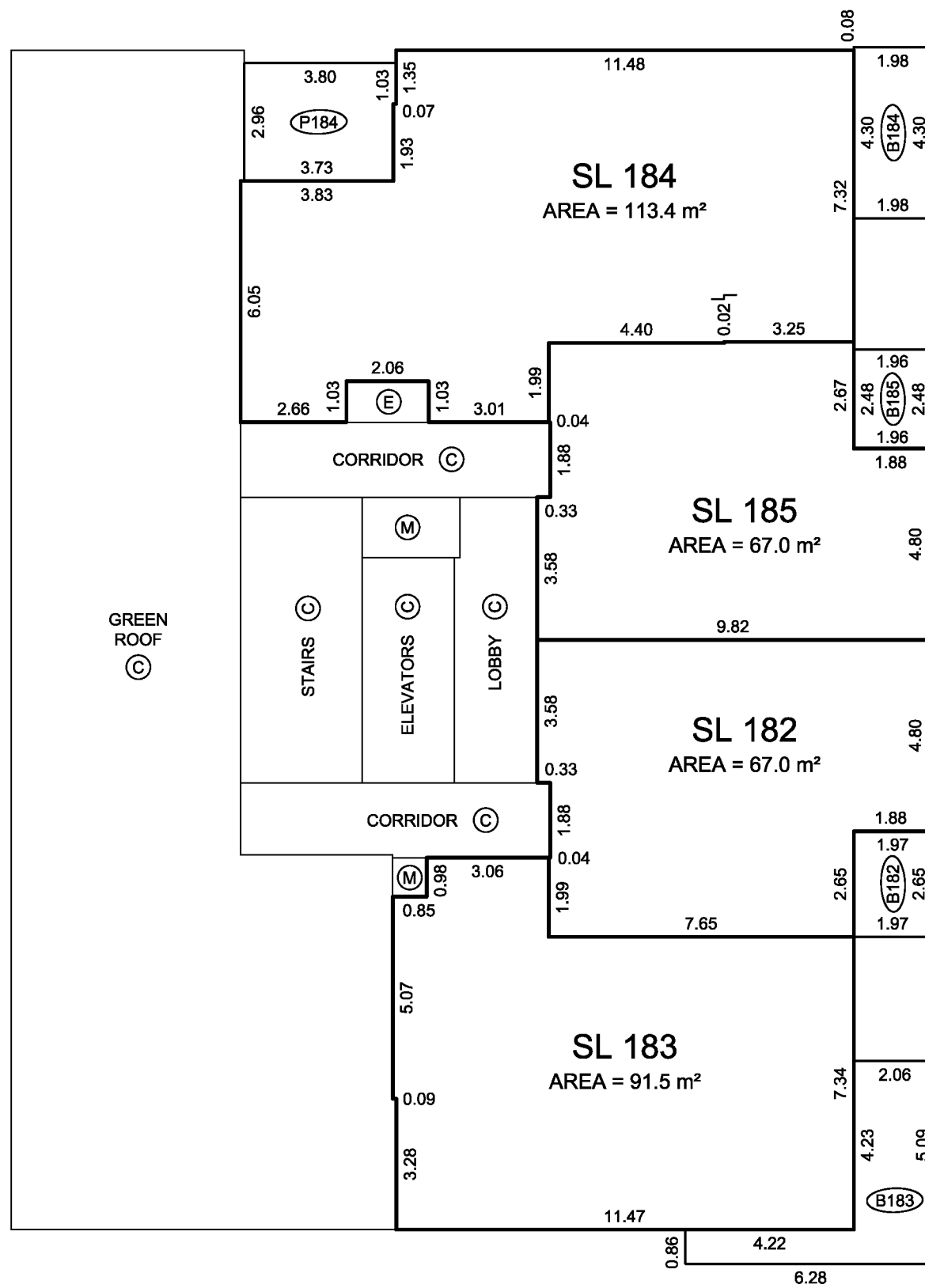
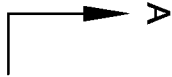

J. NEIL BENNETT, BCLS #527  
DECEMBER 1, 2014

# LEVEL 15 FLOOR PLAN ( DEVELOPER'S LEVEL 17 )

# STRATA PLAN EPS2328



THE INTENDED PLOT SIZE OF THIS PLAN IS  
280mm IN WIDTH BY 432mm IN HEIGHT (B SIZE)  
WHEN PLOTTED AT A SCALE OF 1:150.

ALL ANGLES ARE 45° OR 90° AND MULTIPLES THEREOF,  
UNLESS OTHERWISE NOTED.

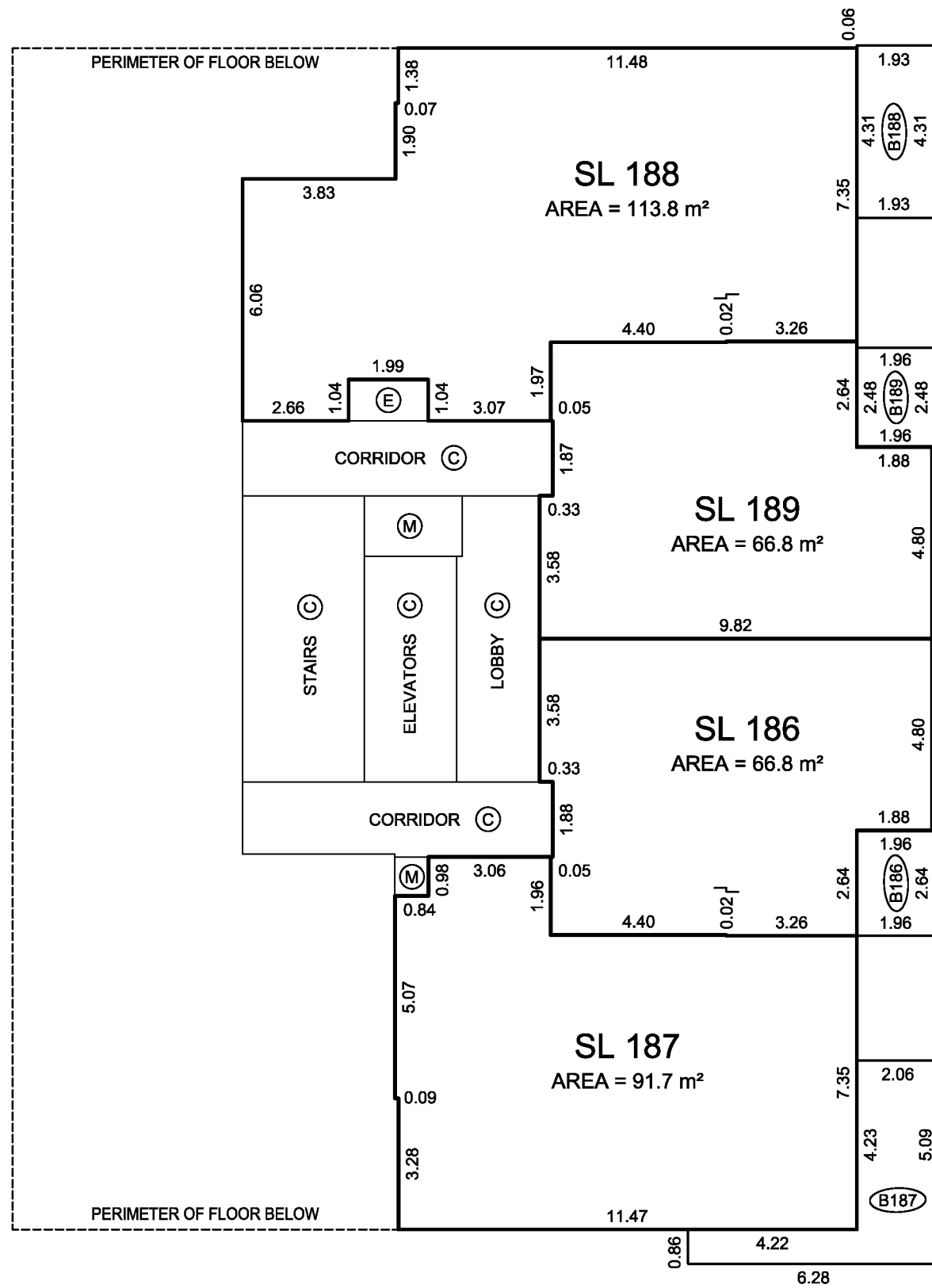
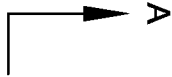

J. NEIL BENNETT, BCLS #527  
DECEMBER 1, 2014

# ROOF LEVEL FLOOR PLAN

# STRATA PLAN EPS2328

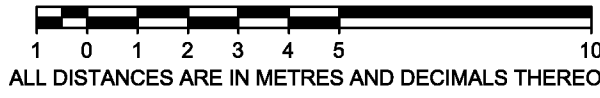

ALL DISTANCES ARE IN METRES AND DECIMALS THEREOF.

THE INTENDED PLOT SIZE OF THIS PLAN IS  
280mm IN WIDTH BY 432mm IN HEIGHT (B SIZE)  
WHEN PLOTTED AT A SCALE OF 1:150.

ALL ANGLES ARE 45° OR 90° AND MULTIPLES THEREOF,  
UNLESS OTHERWISE NOTED.

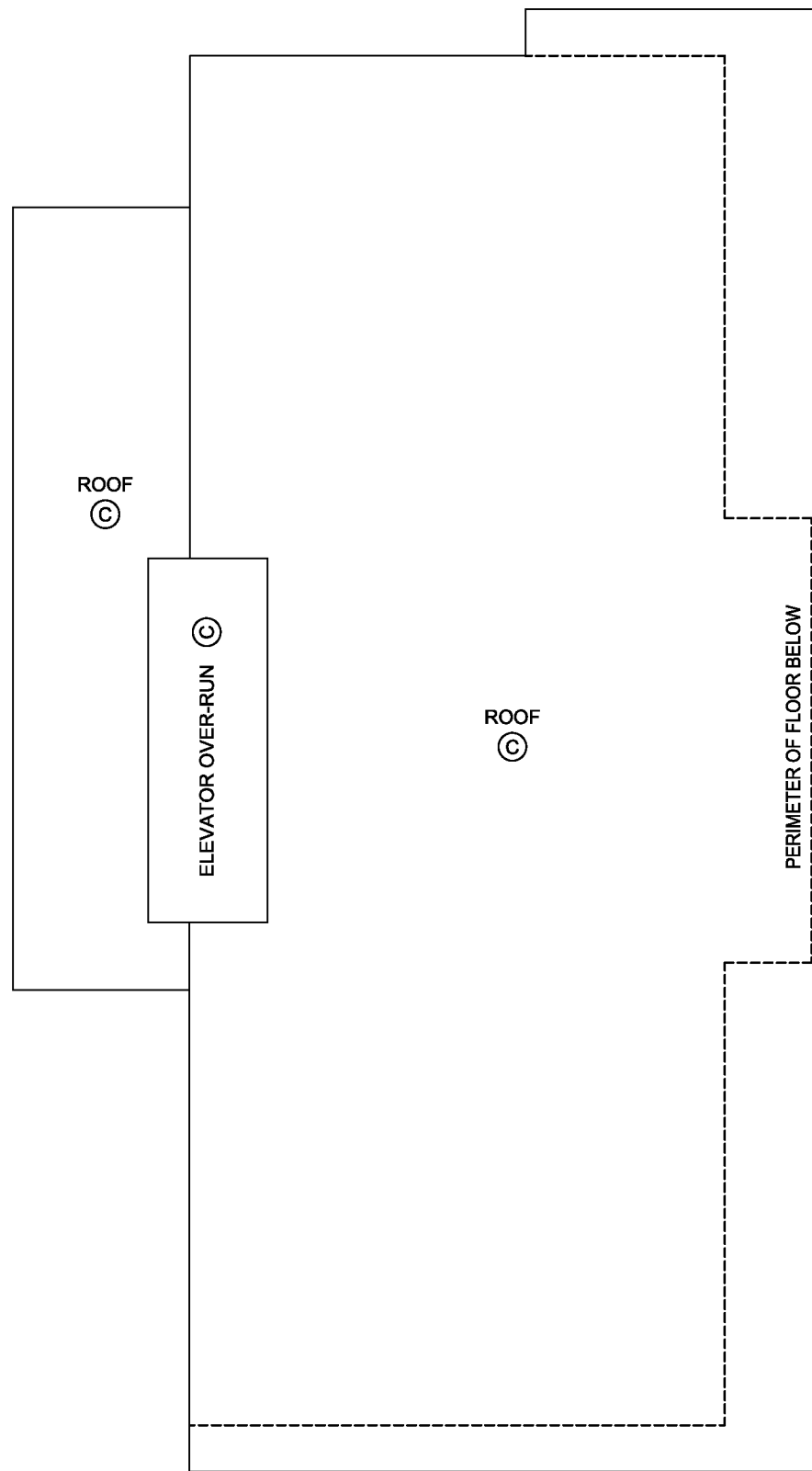
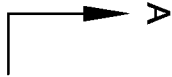

J. NEIL BENNETT, BCLS #527  
DECEMBER 1, 2014

**SECTION A - A**

**STRATA PLAN EPS2328**



ALL DISTANCES ARE IN METRES AND DECIMALS THEREOF.

THE INTENDED PLOT SIZE OF THIS PLAN IS  
280mm IN WIDTH BY 432mm IN HEIGHT (B SIZE)  
WHEN PLOTTED AT A SCALE OF 1:200.

ROOF LEVEL

LEVEL 15  
(DEV LEV 17)

LEVEL 14  
(DEV LEV 16)

LEVEL 13  
(DEV LEV 15)

LEVEL 12  
(DEV LEV 14)

LEVEL 11  
(DEV LEV 12)

LEVEL 10  
(DEV LEV 11)

LEVEL 9  
(DEV LEV 10)

LEVEL 8  
(DEV LEV 9)

LEVEL 7  
(DEV LEV 8)

LEVEL 6  
(DEV LEV 7)

LEVEL 5  
(DEV LEV 6)

LEVEL 4  
(DEV LEV 5)

LEVEL 3

LEVEL 2

LEVEL 1 UPPER  
(NOT TRANSECTED  
BY THIS SECTION)

LEVEL 1

LEVEL P1B  
(LOWER)

LEVEL P2B  
(LOWER)

LEVEL P3B  
(LOWER)

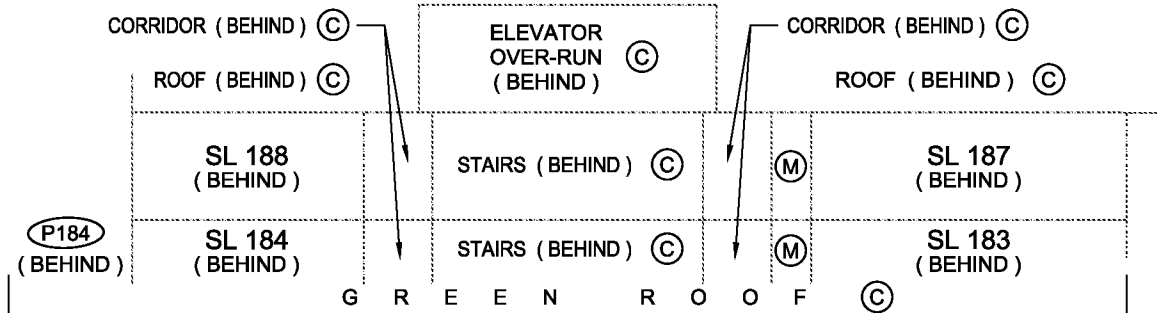

SL 179	SL 178	SL 177	SL 176
SL 171	SL 170	SL 169	SL 168
SL 163	SL 162	SL 161	SL 160
SL 155	SL 154	SL 153	SL 152
SL 147	SL 146	SL 145	SL 144
SL 139	SL 138	SL 137	SL 136
SL 131	SL 130	SL 129	SL 128

LEVEL 6 (DEV LEV 7) details: SL 123, PT ASP 'B', ASP BDY AT EL = 23.20, ASP BDY AT EL = 20.60.

SL 118	SL 117	ASP BDY AT EL = 17.55	SL 94
SL 88	SL 87	(COR)	SL 64
SL 58	SL 57	(COR)	SL 34

SL 28	AMENITY ROOM (C)	(COR)	SL 6
-------	------------------	-------	------

LEVEL 1 UPPER (NOT TRANSECTED BY THIS SECTION) details: RAMP (C), PT ASP 'A', ASP BDY AT EL = 9.60, ASP BDY AT EL = 5.25.

CABLE ROOM (C)	PARKING (C) LEVEL P1B (LOWER) LEASE PLAN EPP44322	RAMP (C)	DRIVEWAY (C) LEVEL P1A (HIGHER) LEASE PLAN EPP44322	GARBAGE AND RECYCLING ROOM (C)
PARKING (C) LEVEL P2B (LOWER) LEASE PLAN EPP44322	RAMP (C)	PARKING (C) LEVEL P2A (HIGHER) LEASE PLAN EPP44322	PARKING (C) LEVEL P3A (HIGHER) LEASE PLAN EPP44322	
PARKING (C) LEVEL P3B (LOWER) LEASE PLAN EPP44322				

(TO PROPERTY LINE)

(RAMP TO PROPERTY LINE)

SRW PLAN BCP50720

J. NEIL BENNETT, BCLS #527  
DECEMBER 1, 2014