

STRATA PLAN OF LOT A, BLOCK 156, DISTRICT LOT 264A, GROUP 1, NEW WESTMINSTER DISTRICT, PLAN EPP56692.

STRATA PLAN EPS5569

CITY OF VANCOUVER
BCGS 92G.025

MIDTOWN 2
630 EAST BROADWAY

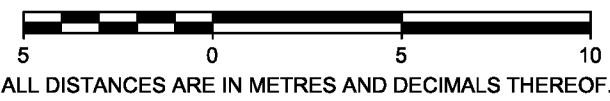

ALL DISTANCES ARE IN METRES AND DECIMALS THEREOF.
THE INTENDED PLOT SIZE OF THIS PLAN IS 560mm IN WIDTH BY 432mm IN HEIGHT (C SIZE) WHEN PLOTTED AT A SCALE OF 1:200

UTM COORDINATES DERIVED FROM ISA MONUMENTS				
DATUM: NAD83 (CSRS) 4.0.0.BC.1.GVRD, UTM ZONE 10.				
MONUMENT	NORTHING	EASTING	ESTIMATED ABSOLUTE POSITIONAL ACCURACY	COMBINED FACTOR
60	5456623.984	493506.279	0.01	0.9995965
V-1763	5456525.582	493506.835	0.01	0.9995961

NOTE: FOR MAPPING PURPOSES ONLY.

THE UTM COORDINATES AND ESTIMATED ABSOLUTE ACCURACY ACHIEVED ARE DERIVED FROM THE MASCOT PUBLISHED COORDINATES AND STANDARD DEVIATIONS FOR GEODETIC CONTROL MONUMENTS 60 AND V-1763.

LEGEND

- - DENOTES STANDARD IRON POST FOUND
 - - DENOTES LEAD PLUG PLACED
 - - DENOTES STANDARD LEAD PLUG FOUND
 - ▲ - DENOTES CONTROL MONUMENT
 - D - DENOTES PREVIOUSLY FOUND IRON POST OR LEAD PLUG NOW DESTROYED
 - US - DENOTES UNSUITABLE FOR POSTING
 - A - DENOTES AREA
 - Bk - DENOTES BLOCK
 - LCP - DENOTES LIMITED COMMON PROPERTY
 - PFB - DENOTES PREMIERE OF FLOOR BELOW
 - PT - DENOTES PART
 - SL - DENOTES STRATA LOT
 - © - DENOTES COMMON PROPERTY
 - ⓔ - DENOTES ELECTRICAL COMMON PROPERTY
 - Ⓥ - DENOTES VENT COMMON PROPERTY
 - B20 - DENOTES BALCONY LCP FOR SL 20 (TYPICAL)
 - D39 - DENOTES DECK LCP FOR SL 39 (TYPICAL)
 - P1 - DENOTES PATIO LCP FOR SL 1 (TYPICAL)
 - S39 - DENOTES STAIR LCP FOR SL 39 (TYPICAL)
 - CML - DENOTES LIMITED COMMON PROPERTY FOR COMMERCIAL STRATA LOTS BEING SL 51 AND SL 52
 - RES - DENOTES LIMITED COMMON PROPERTY FOR RESIDENTIAL STRATA LOTS BEING SL 1 TO SL 50
- CLEAR 0.01 → - DENOTES BUILDING 0.01 CLEAR OF PROPERTY LINE

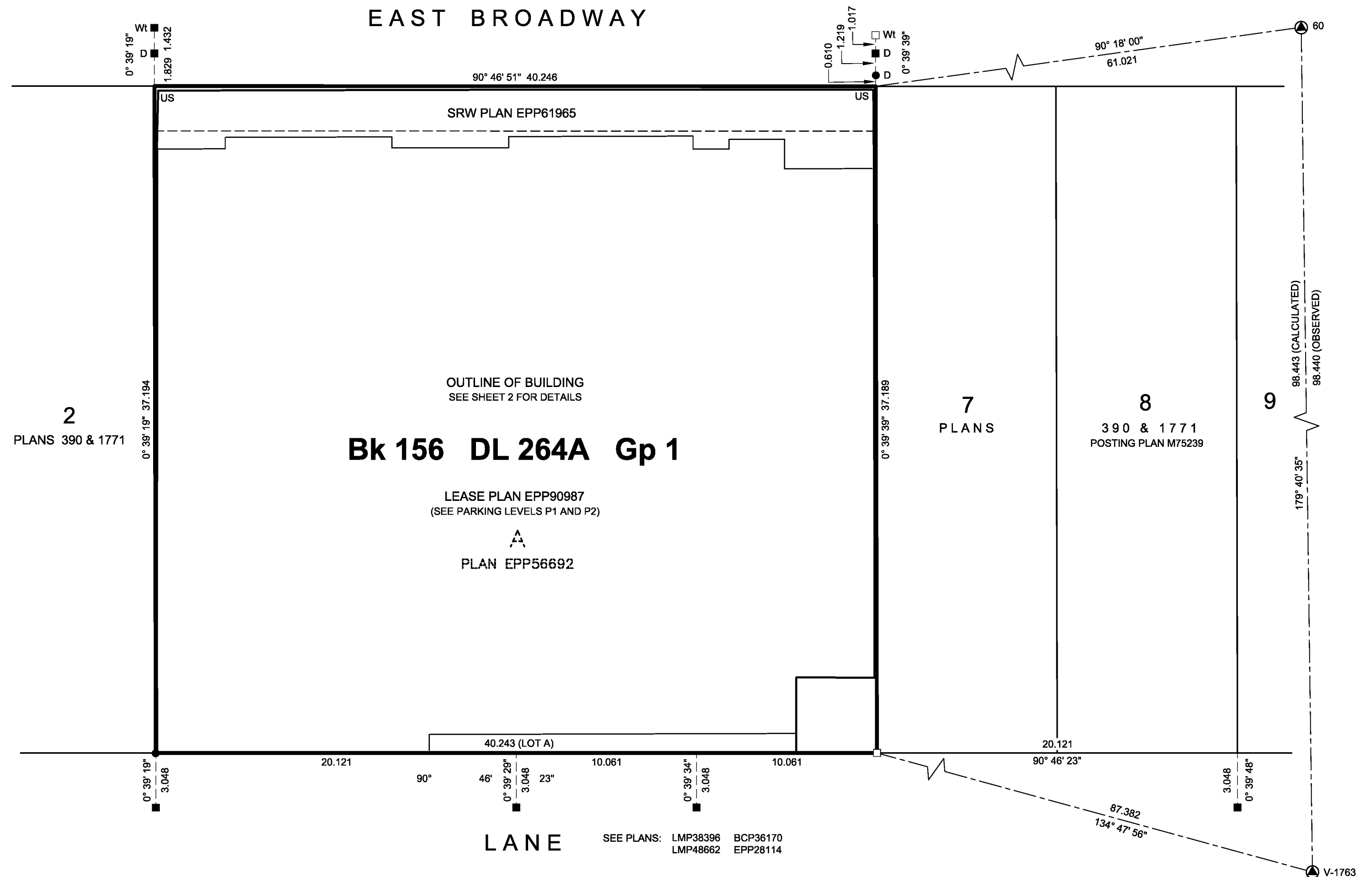

THIS PLAN LIES WITHIN INTEGRATED SURVEY AREA No. 31, CITY OF VANCOUVER, NAD83(CSRS) 4.0.0.BC.1.GVRD.

GRID BEARINGS ARE DERIVED FROM OBSERVATIONS BETWEEN GEODETIC CONTROL MONUMENTS 60 AND V-1763 AND ARE REFERRED TO THE CENTRAL MERIDIAN OF UTM ZONE 10.

THIS PLAN SHOWS HORIZONTAL GROUND LEVEL DISTANCES UNLESS OTHERWISE SPECIFIED. TO COMPUTE GRID DISTANCES, MULTIPLY GROUND LEVEL DISTANCES BY THE AVERAGE COMBINED FACTOR OF 0.9995963: WHICH HAS BEEN DERIVED FROM GEODETIC CONTROL MONUMENTS 60 AND V-1763.

bennett
LAND SURVEYING LTD.
BC LAND SURVEYORS
#201 - 275 FELL AVENUE
NORTH VANCOUVER, BC
V7P 3R5
TEL 604-980-4868
www.bennettsurveys.com

FB811 P24-28 (GK/JH), FB858 P150-152 (GK) AND
FB892 P16-19 (GK)

THIS PLAN SHOWS ONE OR MORE WITNESS POSTS WHICH ARE NOT SET ON THE TRUE CORNER(S).
WITNESS POSTS ARE ON THE PRODUCTION OF PROPERTY LINES UNLESS OTHERWISE NOTED.

THE BOUNDARY OF THE STRATA LOT IS MIDWAY BETWEEN THE SURFACE OF THE STRUCTURAL PORTION OF THE WALL, FLOOR OR CEILING THAT FACES THE STRATA LOT AND THE SURFACE OF THE STRUCTURAL PORTION OF THE WALL, FLOOR OR CEILING THAT FACES THE OTHER STRATA LOT, THE COMMON PROPERTY OR THE OTHER PARCEL OF LAND.

EXTERIOR LCP AREAS ARE DEFINED AS TO HEIGHT BY THE CENTRE OF THE FLOOR ABOVE OR ITS EXTENSIONS OR WHERE THERE IS NO FLOOR ABOVE, BY THE AVERAGE HEIGHT OF A STRATA LOT WITHIN THE SAME BUILDING, UNLESS OTHERWISE NOTED.

THIS PLAN LIES WITHIN THE METRO VANCOUVER REGIONAL DISTRICT

THE BUILDING SHOWN HEREON IS WITHIN THE EXTERNAL BOUNDARIES OF THE LAND THAT IS THE SUBJECT OF THE STRATA PLAN.

THE BUILDING INCLUDED IN THIS STRATA PLAN HAS NOT BEEN PREVIOUSLY OCCUPIED.

THE FIELD SURVEY REPRESENTED BY THIS PLAN WAS COMPLETED ON THE 6TH DAY OF MARCH, 2019.
PATRICK KORABEK, BCLS #783

BUILDING DETAIL

STRATA PLAN EPS5569

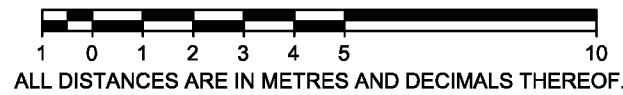

ALL DISTANCES ARE IN METRES AND DECIMALS THEREOF.

THE INTENDED PLOT SIZE OF THIS PLAN IS 560mm IN WIDTH BY 432mm IN HEIGHT (C SIZE) WHEN PLOTTED AT A SCALE OF 1:150

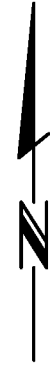

bennett
 LAND SURVEYING LTD.
 BC LAND SURVEYORS
 #201 - 275 FELL AVENUE
 NORTH VANCOUVER, BC
 V7P 3R5
 TEL 604-980-4868
 www.bennettsurveys.com

PATRICK KORABEK, BCLS
 6TH DAY OF MARCH, 2019.

PARKING LEVEL P2 FLOOR PLAN

STRATA PLAN EPS5569



ALL DISTANCES ARE IN METRES AND DECIMALS THEREOF.

THE INTENDED PLOT SIZE OF THIS PLAN IS 560mm IN WIDTH BY 432mm IN HEIGHT (C SIZE) WHEN PLOTTED AT A SCALE OF 1:150

ALL ANGLES ARE 45° OR 90° AND MULTIPLES THEREOF, UNLESS OTHERWISE NOTED.

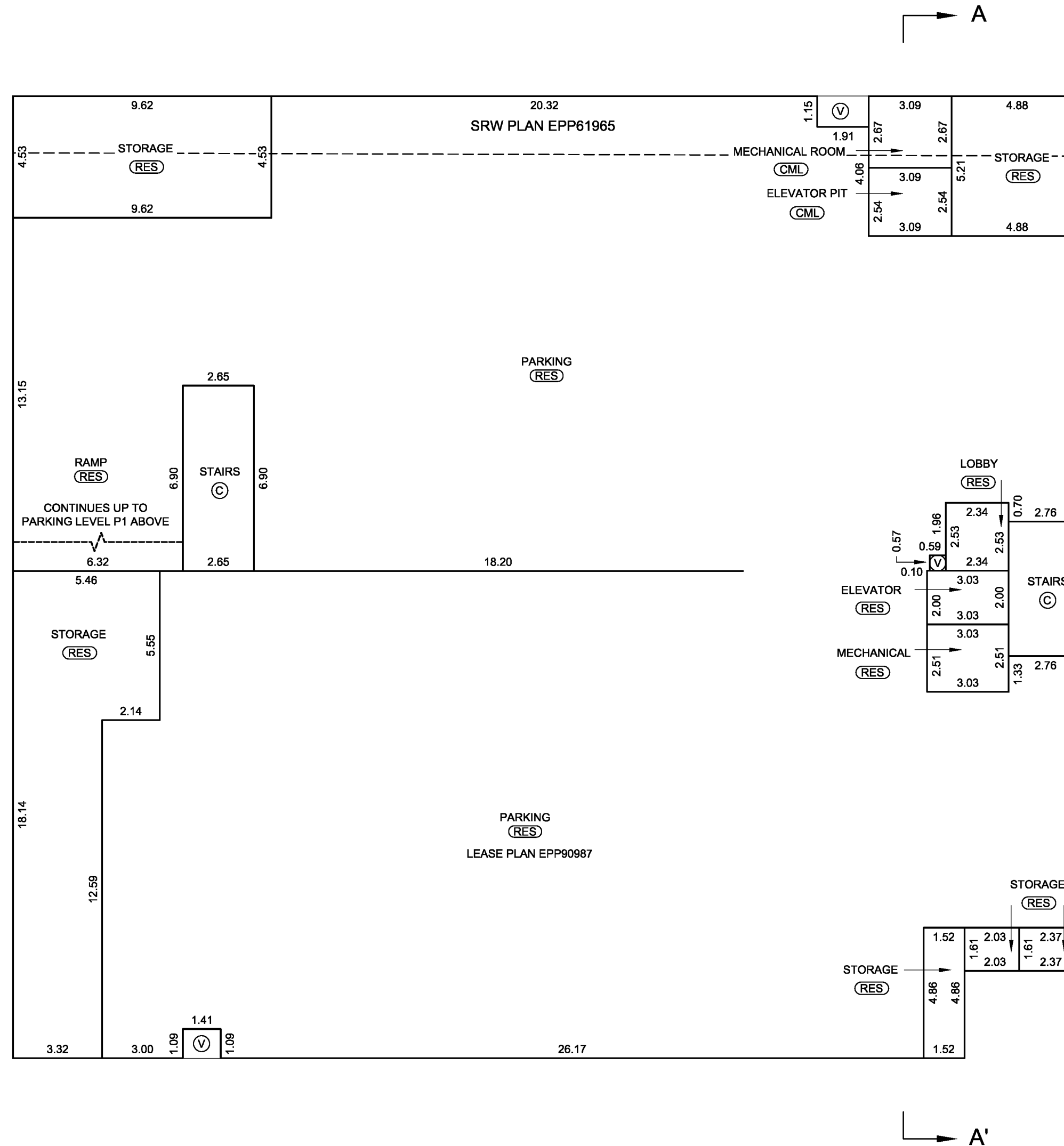

bennett
 LAND SURVEYING LTD.
 BC LAND SURVEYORS
 #201 - 275 FELL AVENUE
 NORTH VANCOUVER, BC
 V7P 3R5
 TEL 604-980-4868
 www.bennettsurveys.com

PATRICK KORABEK, BCLS
 6TH DAY OF MARCH, 2019.

PARKING LEVEL P1 FLOOR PLAN

STRATA PLAN EPS5569



ALL DISTANCES ARE IN METRES AND DECIMALS THEREOF.

THE INTENDED PLOT SIZE OF THIS PLAN IS 560mm IN WIDTH BY 432mm IN HEIGHT (C SIZE) WHEN PLOTTED AT A SCALE OF 1:150

ALL ANGLES ARE 45° OR 90° AND MULTIPLES THEREOF, UNLESS OTHERWISE NOTED.

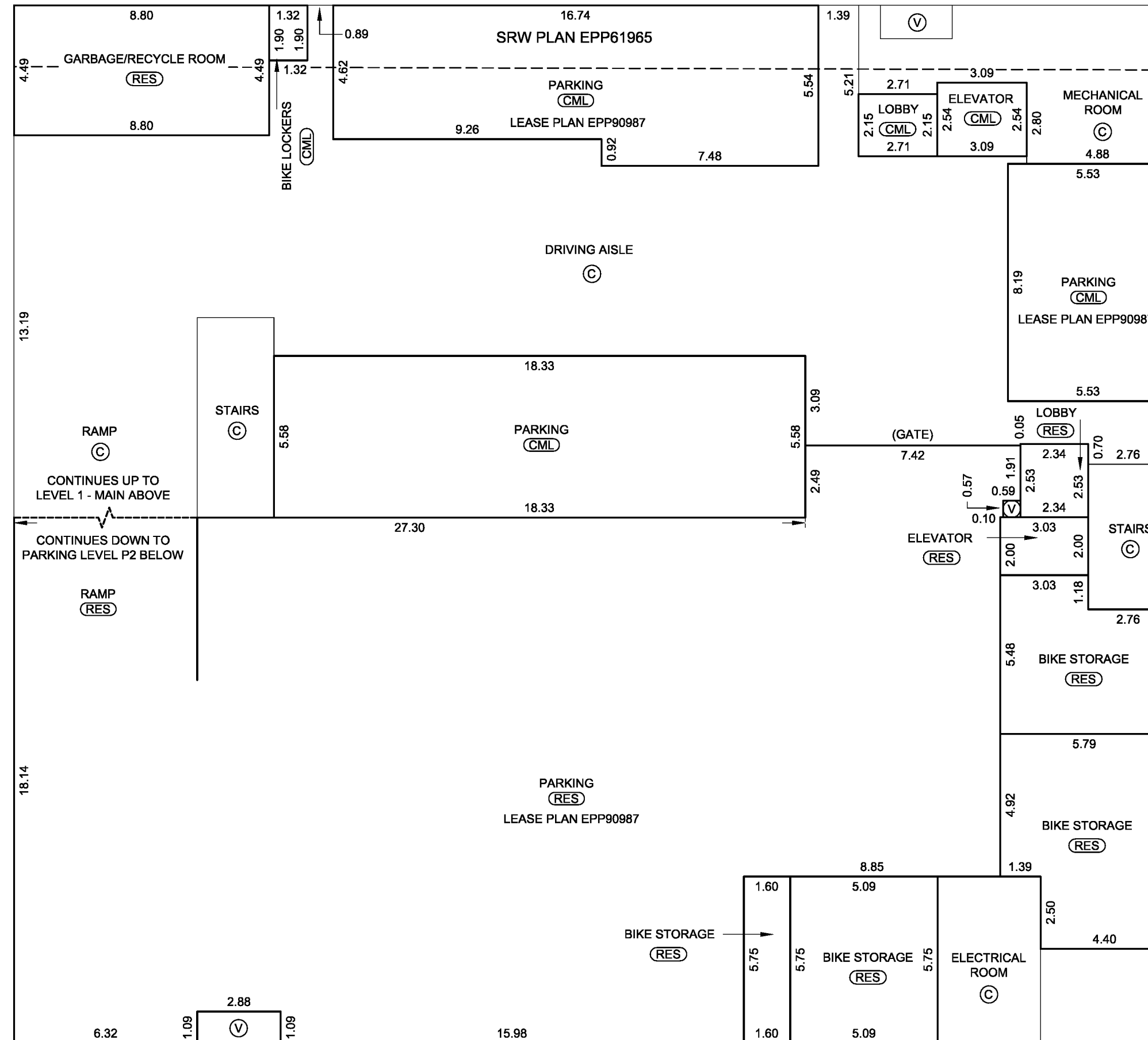
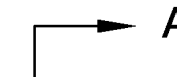
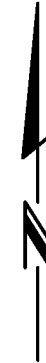

bennett
 LAND SURVEYING LTD.
 BC LAND SURVEYORS
 #201 - 275 FELL AVENUE
 NORTH VANCOUVER, BC
 V7P 3R5
 TEL 604-980-4868
 www.bennettsurveys.com

PATRICK KORABEK, BCLS
 6TH DAY OF MARCH, 2019.

LEVEL 1 - MAIN FLOOR PLAN

STRATA PLAN EPS5569



ALL DISTANCES ARE IN METRES AND DECIMALS THEREOF.

THE INTENDED PLOT SIZE OF THIS PLAN IS 560mm IN WIDTH BY 432mm IN HEIGHT (C SIZE) WHEN PLOTTED AT A SCALE OF 1:150

ALL ANGLES ARE 45° OR 90° AND MULTIPLES THEREOF, UNLESS OTHERWISE NOTED.

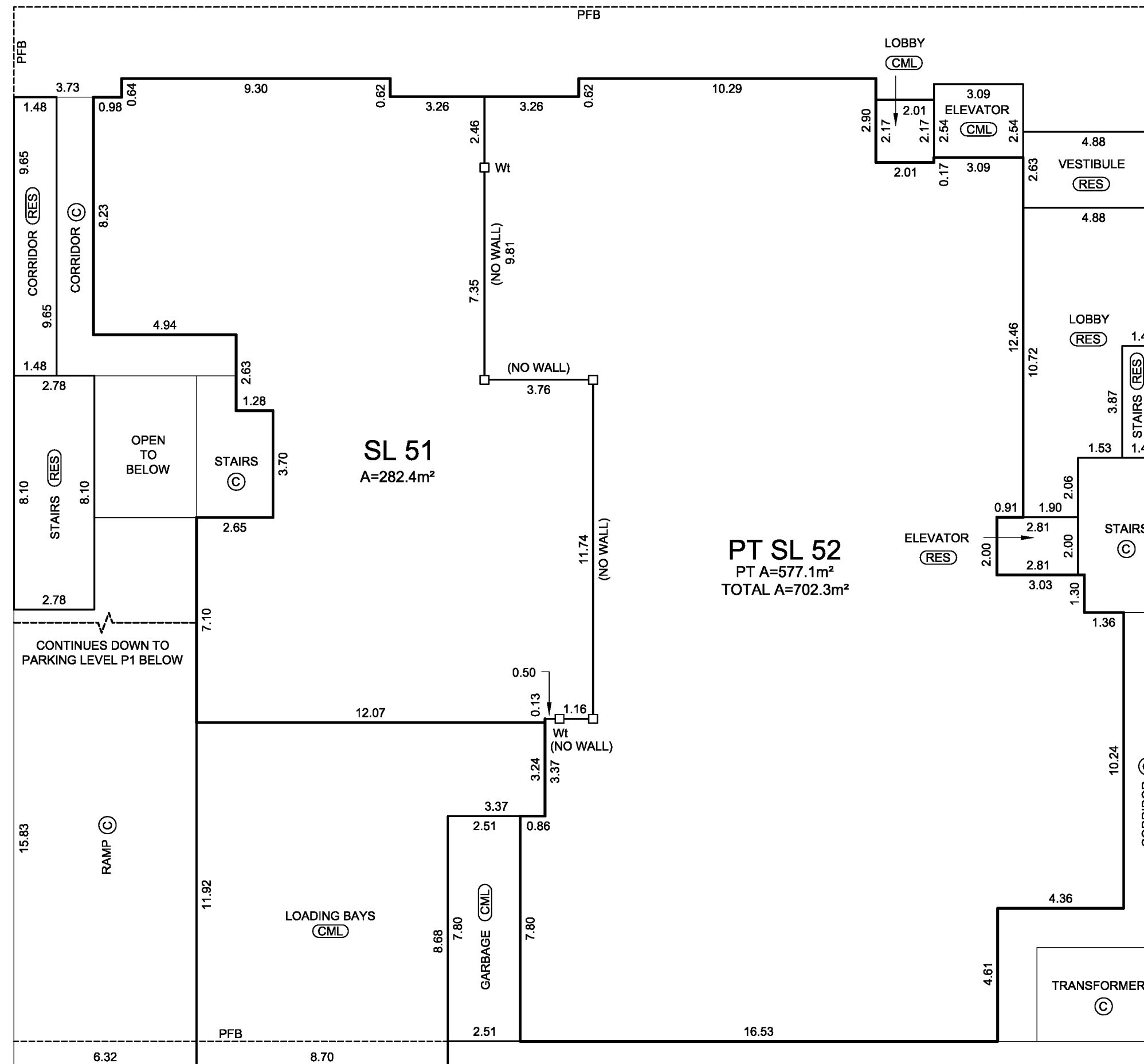
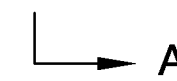
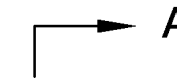

bennett
 LAND SURVEYING LTD.
 BC LAND SURVEYORS
 #201 - 275 FELL AVENUE
 NORTH VANCOUVER, BC
 V7P 3R5
 TEL 604-980-4868
 www.bennettsurveys.com

PATRICK KORABEK, BCLS
 6TH DAY OF MARCH, 2019.

LEVEL 1 - MEZZANINE FLOOR PLAN

STRATA PLAN EPS5569



ALL DISTANCES ARE IN METRES AND DECIMALS THEREOF.

THE INTENDED PLOT SIZE OF THIS PLAN IS 560mm IN WIDTH BY 432mm IN HEIGHT (C SIZE) WHEN PLOTTED AT A SCALE OF 1:150

ALL ANGLES ARE 45° OR 90° AND MULTIPLES THEREOF, UNLESS OTHERWISE NOTED.

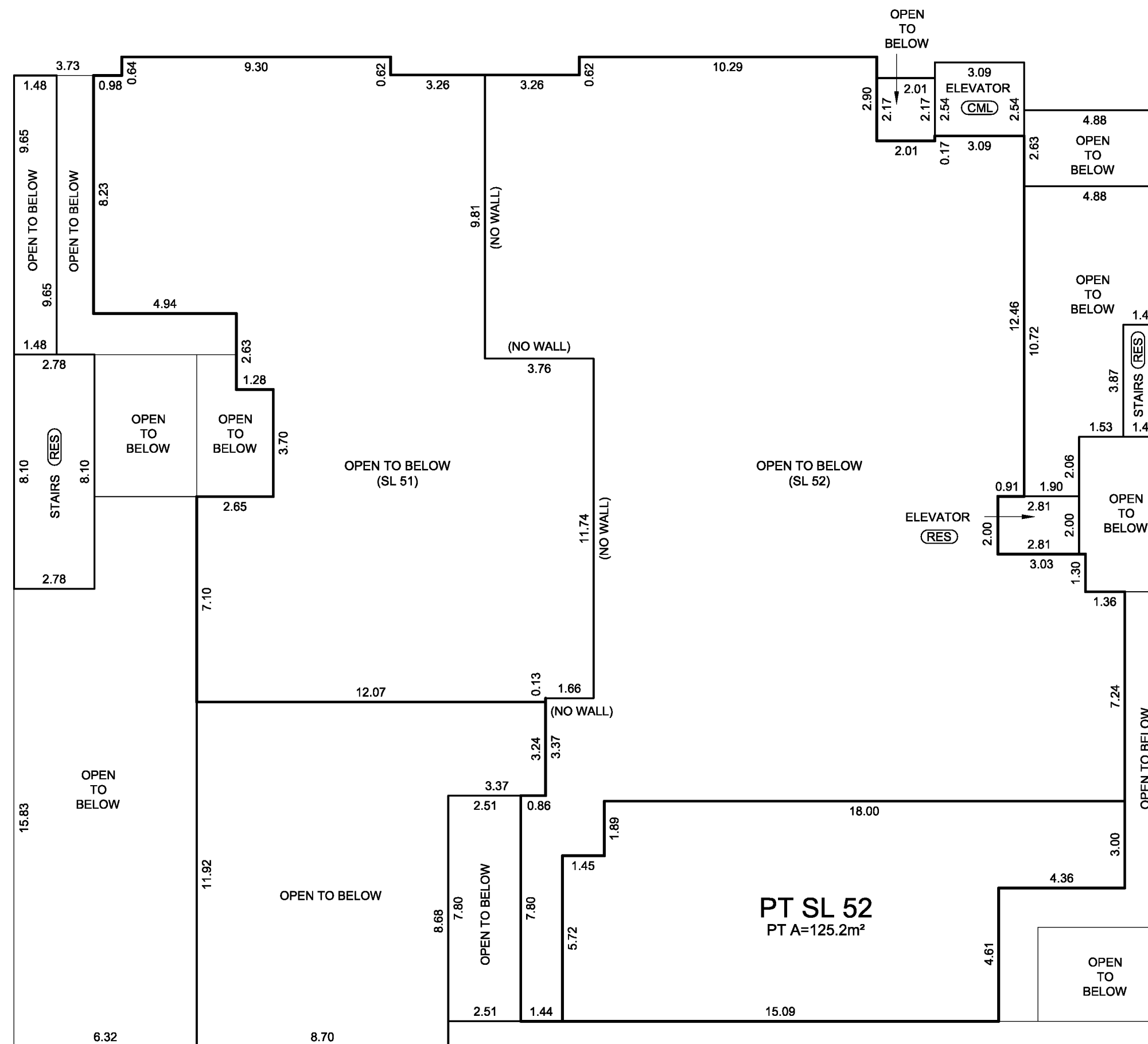
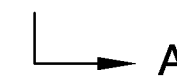
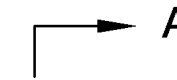

bennett
 LAND SURVEYING LTD.
 BC LAND SURVEYORS
 #201 - 275 FELL AVENUE
 NORTH VANCOUVER, BC
 V7P 3R5
 TEL 604-980-4868
 www.bennettsurveys.com

PATRICK KORABEK, BCLS
 6TH DAY OF MARCH, 2019.

LEVEL 2 FLOOR PLAN

STRATA PLAN EPS5569



ALL DISTANCES ARE IN METRES AND DECIMALS THEREOF.

THE INTENDED PLOT SIZE OF THIS PLAN IS 560mm IN WIDTH BY 432mm IN HEIGHT (C SIZE) WHEN PLOTTED AT A SCALE OF 1:150

ALL ANGLES ARE 45° OR 90° AND MULTIPLES THEREOF, UNLESS OTHERWISE NOTED.

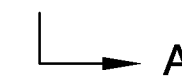
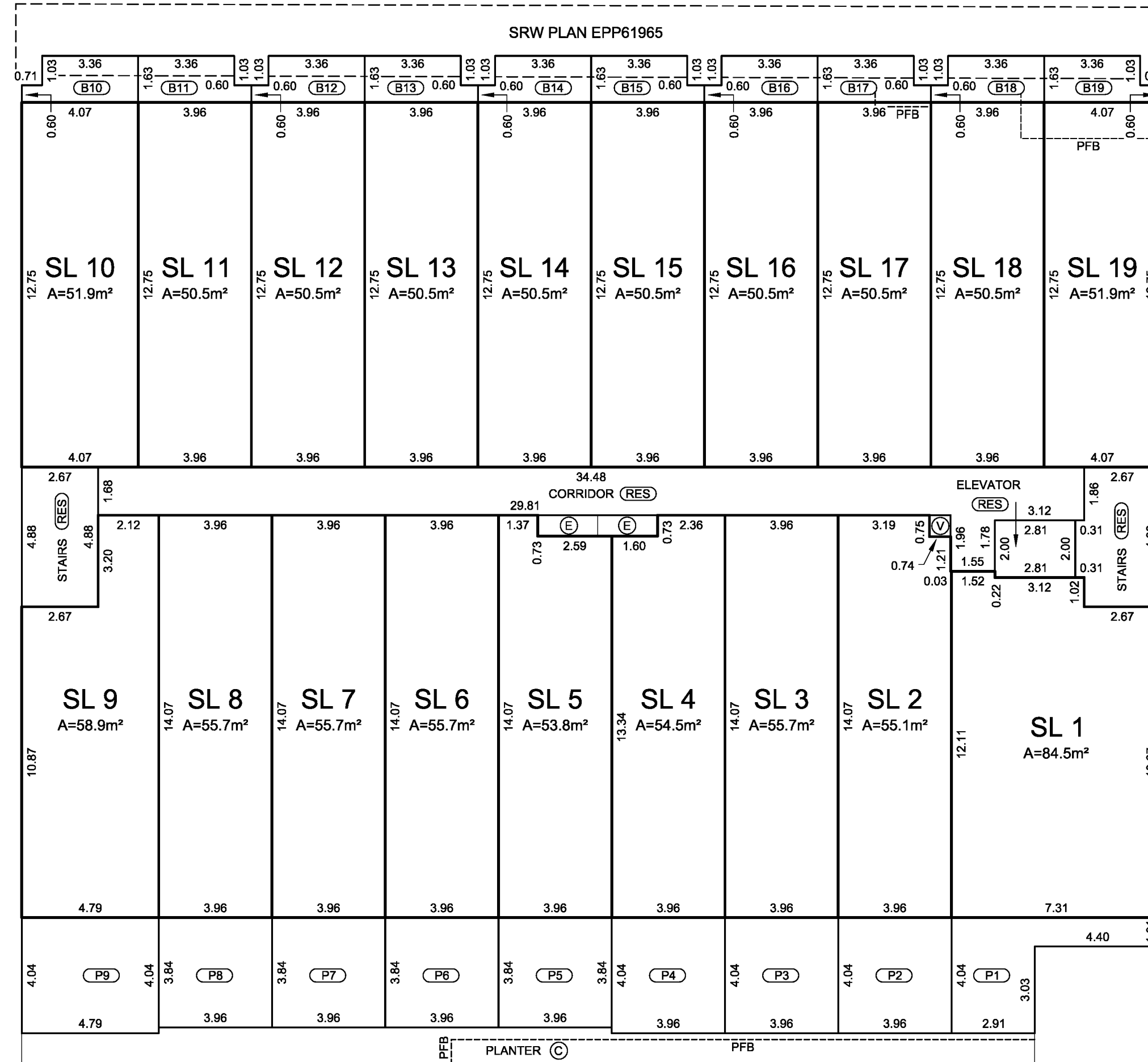
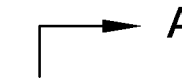

bennett
 LAND SURVEYING LTD.
 BC LAND SURVEYORS
 #201 - 275 FELL AVENUE
 NORTH VANCOUVER, BC
 V7P 3R5
 TEL 604-980-4868
 www.bennettsurveys.com

PATRICK KORABEK, BCLS
 6TH DAY OF MARCH, 2019.

LEVEL 3 FLOOR PLAN

STRATA PLAN EPS5569



ALL DISTANCES ARE IN METRES AND DECIMALS THEREOF.

THE INTENDED PLOT SIZE OF THIS PLAN IS 560mm IN WIDTH BY 432mm IN HEIGHT (C SIZE) WHEN PLOTTED AT A SCALE OF 1:150

ALL ANGLES ARE 45° OR 90° AND MULTIPLES THEREOF, UNLESS OTHERWISE NOTED.

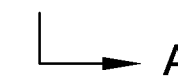
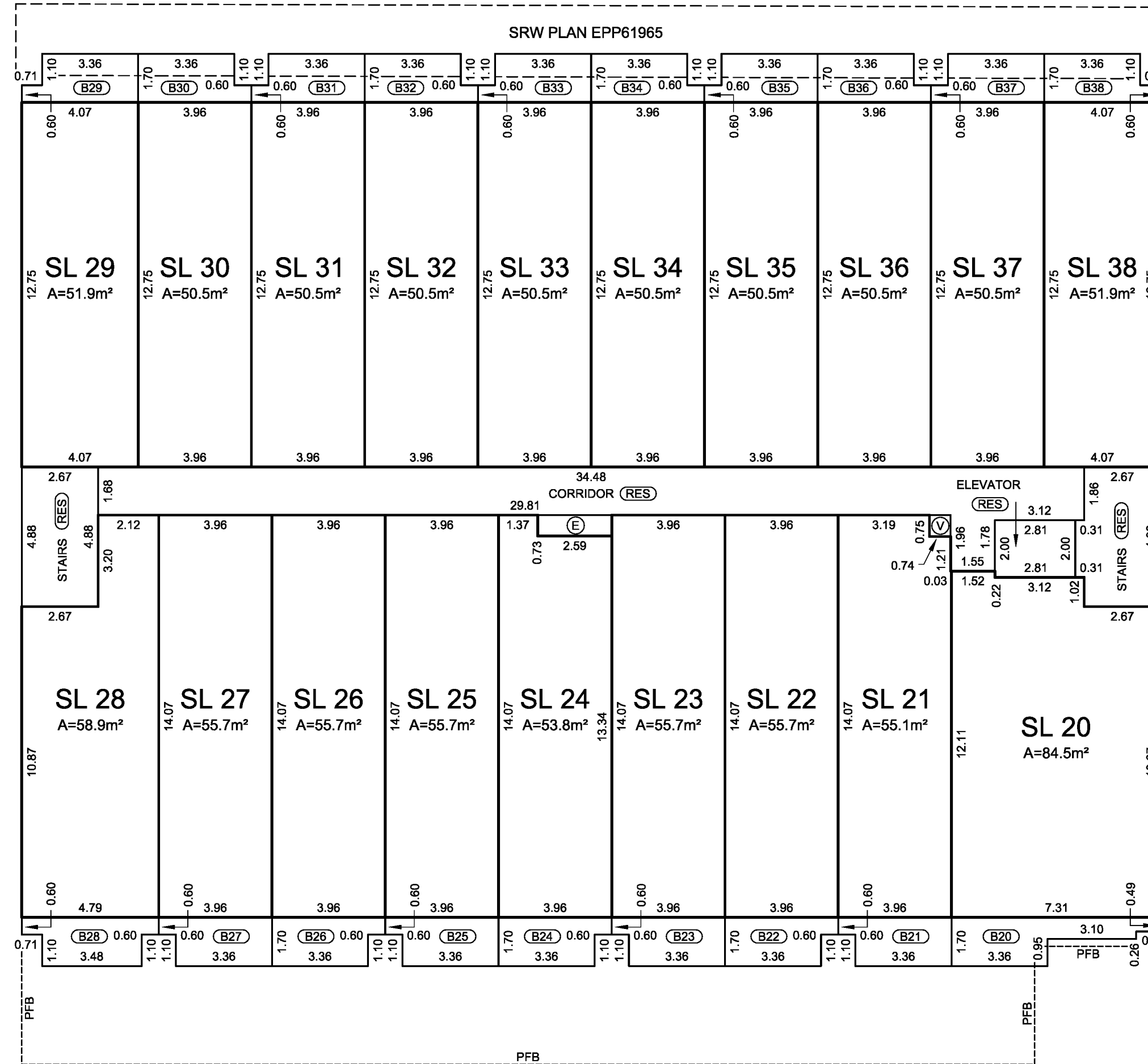
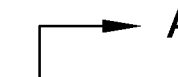
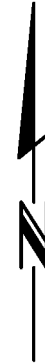

bennett
 LAND SURVEYING LTD.
 BC LAND SURVEYORS
 #201 - 275 FELL AVENUE
 NORTH VANCOUVER, BC
 V7P 3R5
 TEL 604-980-4868
 www.bennettsurveys.com

PATRICK KORABEK, BCLS
 6TH DAY OF MARCH, 2019.

LEVEL 4 FLOOR PLAN

STRATA PLAN EPS5569



ALL DISTANCES ARE IN METRES AND DECIMALS THEREOF.

THE INTENDED PLOT SIZE OF THIS PLAN IS 560mm IN WIDTH BY 432mm IN HEIGHT (C SIZE) WHEN PLOTTED AT A SCALE OF 1:150

ALL ANGLES ARE 45° OR 90° AND MULTIPLES THEREOF, UNLESS OTHERWISE NOTED.

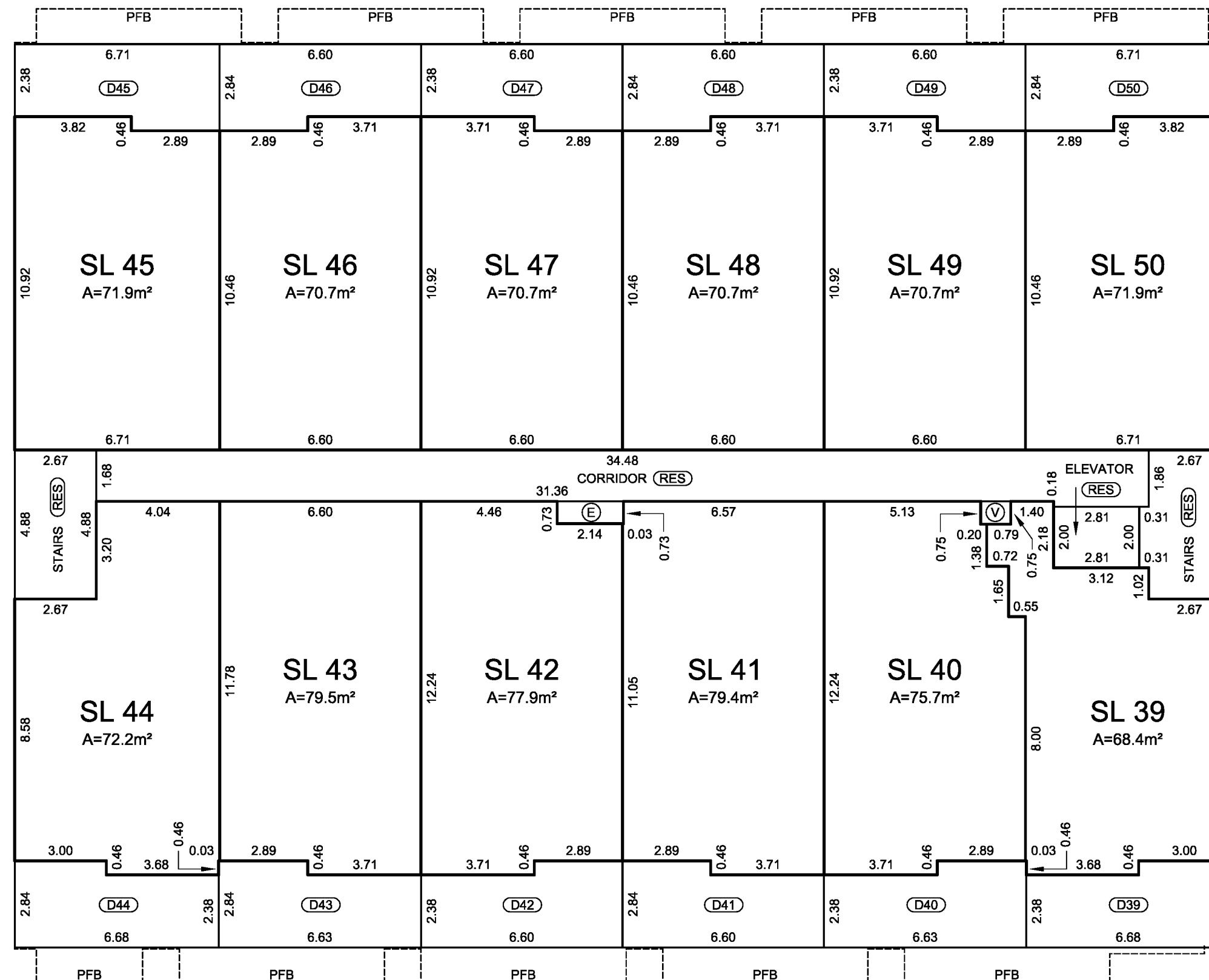
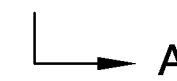
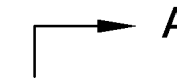

bennett
 LAND SURVEYING LTD.
 BC LAND SURVEYORS
 #201 - 275 FELL AVENUE
 NORTH VANCOUVER, BC
 V7P 3R5
 TEL 604-980-4868
 www.bennettsurveys.com

PATRICK KORABEK, BCLS
 6TH DAY OF MARCH, 2019.

LEVEL 5 - ROOF FLOOR PLAN

STRATA PLAN EPS5569



ALL DISTANCES ARE IN METRES AND DECIMALS THEREOF.

THE INTENDED PLOT SIZE OF THIS PLAN IS 560mm IN WIDTH BY 432mm IN HEIGHT (C SIZE) WHEN PLOTTED AT A SCALE OF 1:150

ALL ANGLES ARE 45° OR 90° AND MULTIPLES THEREOF, UNLESS OTHERWISE NOTED.



STAIR DETAIL

S45 TO S50 (TYPICAL)
NOT TO SCALE

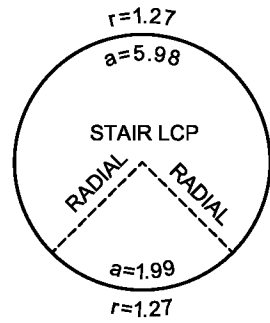

STAIR DETAIL

S39 TO S44 (TYPICAL)
NOT TO SCALE

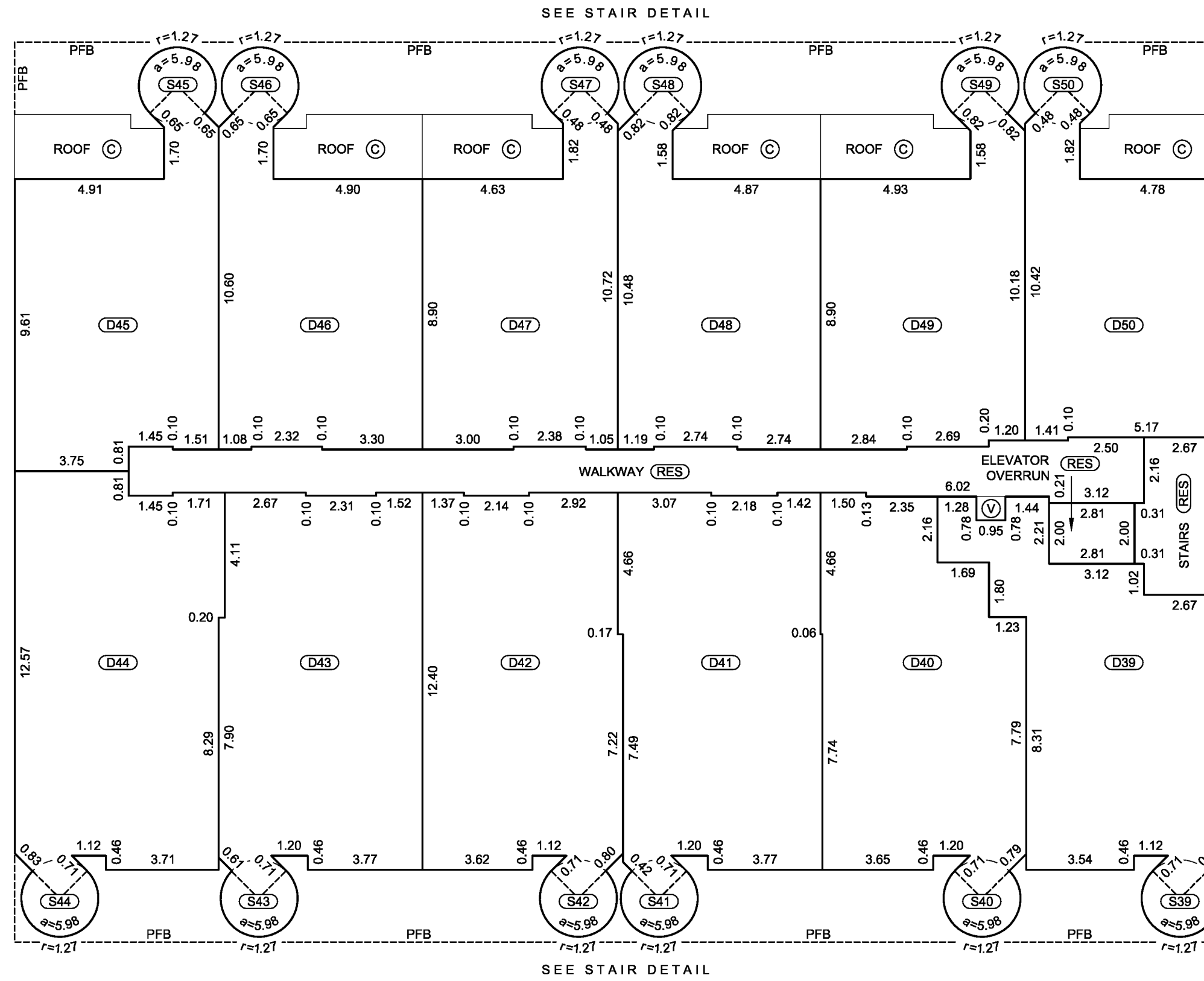
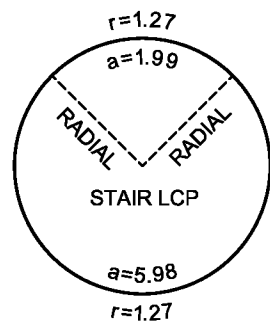

bennett
 LAND SURVEYING LTD.
 BC LAND SURVEYORS
 #201 - 275 FELL AVENUE
 NORTH VANCOUVER, BC
 V7P 3R5
 TEL 604-980-4868
 www.bennettsurveys.com

PATRICK KORABEK, BCLS
 6TH DAY OF MARCH, 2019.

ELEVATOR ROOF FLOOR PLAN

STRATA PLAN EPS5569



ALL DISTANCES ARE IN METRES AND DECIMALS THEREOF.

THE INTENDED PLOT SIZE OF THIS PLAN IS 560mm IN WIDTH BY 432mm IN HEIGHT (C SIZE) WHEN PLOTTED AT A SCALE OF 1:150

ALL ANGLES ARE 45° OR 90° AND MULTIPLES THEREOF, UNLESS OTHERWISE NOTED.

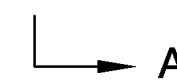
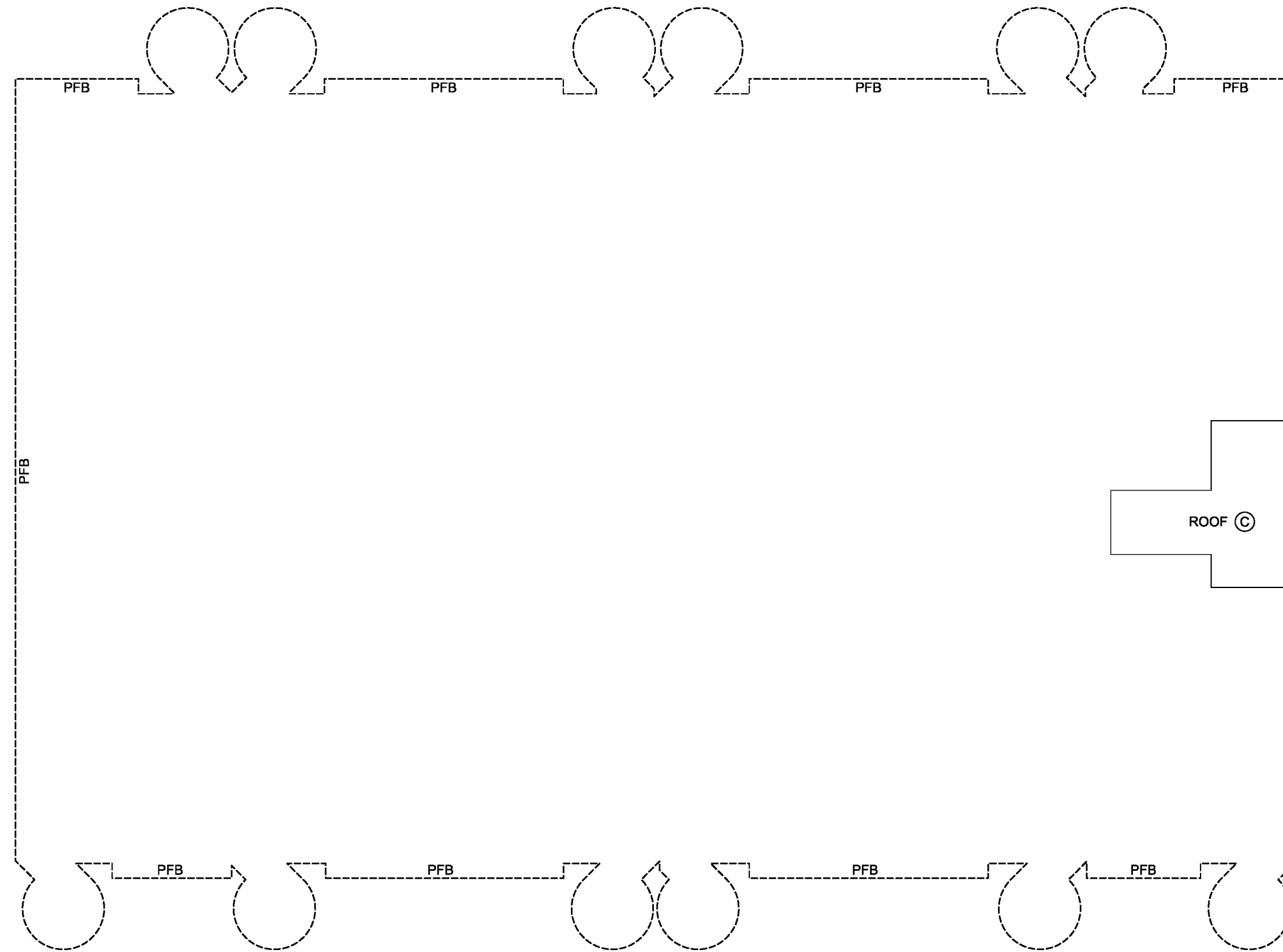
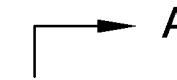

bennett
 LAND SURVEYING LTD.
 BC LAND SURVEYORS
 #201 - 275 FELL AVENUE
 NORTH VANCOUVER, BC
 V7P 3R5
 TEL 604-980-4868
 www.bennettsurveys.com

PATRICK KORABEK, BCLS
 6TH DAY OF MARCH, 2019.

SECTION A - A'

STRATA PLAN EPS5569



ALL DISTANCES ARE IN METRES AND DECIMALS THEREOF.

THE INTENDED PLOT SIZE OF THIS PLAN IS 560mm IN WIDTH BY 432mm IN HEIGHT (C SIZE) WHEN PLOTTED AT A SCALE OF 1:150

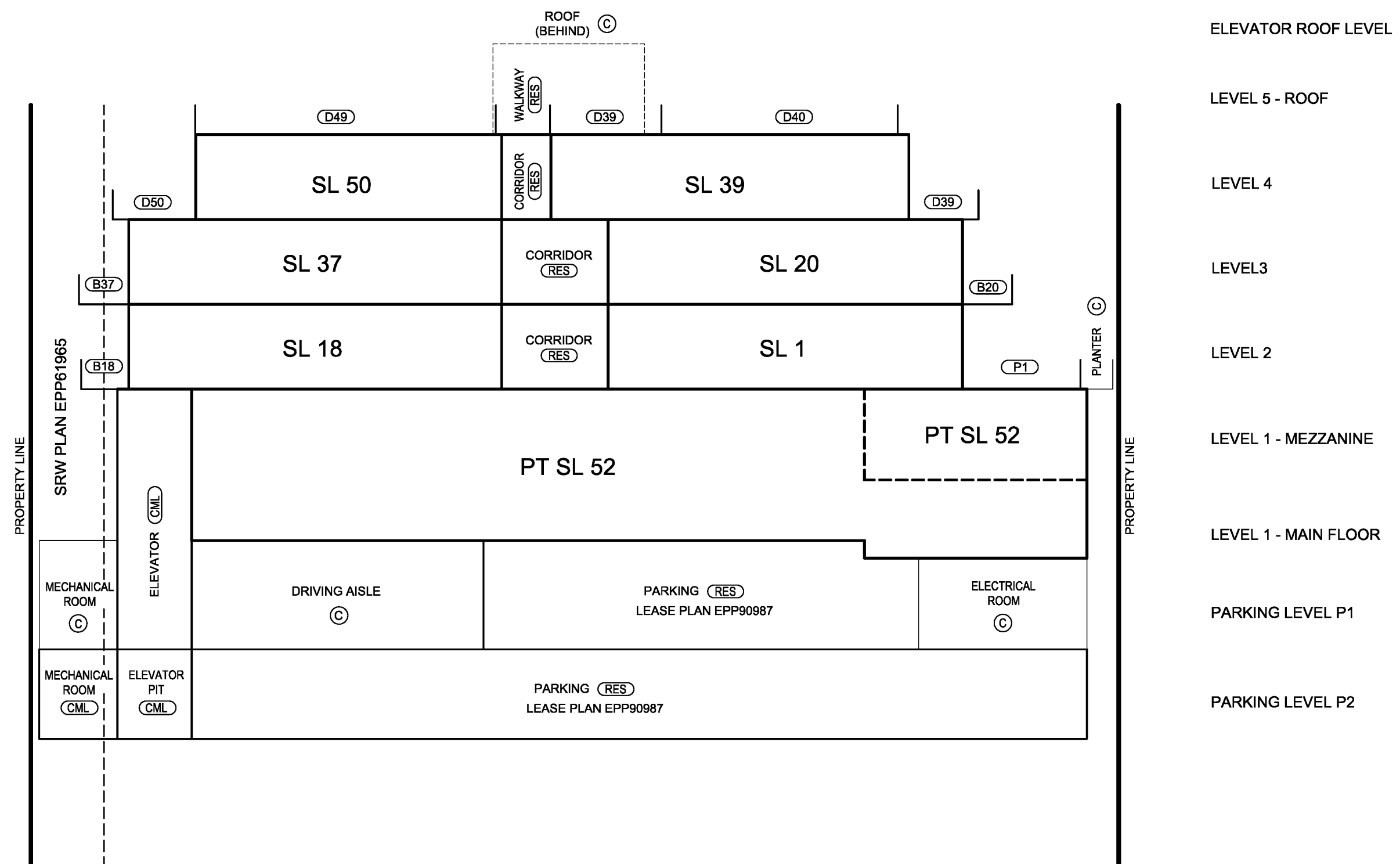

bennett
 LAND SURVEYING LTD.
 BC LAND SURVEYORS
 #201 - 275 FELL AVENUE
 NORTH VANCOUVER, BC
 V7P 3R5
 TEL 604-980-4868
 www.bennettsurveys.com

PATRICK KORABEK, BCLS
 6TH DAY OF MARCH, 2019.